

Adeptia Suite 5.1

Evaluation Guide

Release Date September 14, 2010

Adeptia Inc.
443 North Clark Ave,
Suite 350
Chicago, IL 60654, USA
Phone: (312) 229-1727

Copyright

© 2000-2009 Adeptia, Inc. All rights reserved.

Trademarks

The Adeptia TM logo is a trademark of Adeptia, Inc.

Statement of Conditions

Adeptia, Inc. provides this publication "as is" without warranty of any kind, either express or implied. In no event shall Adeptia be liable for any loss of profits, loss of business, loss of use or data, interruption of business, or for indirect, special, punitive, incidental, or consequential damages of any kind.

No part of this work covered by copyright herein may be reproduced in any form or by any means—graphic, electronic or mechanical—including photocopying, recording, taping, or storage in an information retrieval system, without prior written permission of the copyright owner.

This publication is subject to replacement by a later edition. To determine whether a later edition exists, contact www.adeptia.com.

Document Conventions

Convention	Description
Text Matter in font Verdana and font size 9 point.	Explains the evaluation guide.
Text matter	Click link to reach target.
	Note:

Abbreviations Used

Abbreviation	Description
JMS	Java Messaging Service
CDO	Collaboration Data Object

Contact Information

In case of any queries, please contact us at:

Contact For	Email ID
Sales	sales@adeptia.com
Support	support@adeptia.com

For latest updates and information, please visit us at www.adeptia.com

Table of Contents

1	ABOUT THIS DOCUMENT	6
2	TARGET AUDIENCE.....	8
3	DATA TRANSFORMATION PROCESS FLOW	9
	INTRODUCTION	9
	SERVICES USED IN THIS SAMPLE PROCESS FLOW	9
	DESCRIPTION	9
	USAGE SCENARIO	10
	DATA DESCRIPTION AND MAPPING INFORMATION	10
	PREREQUISITES	11
	POPULATING DATA INTO DATABASE	12
	EXECUTING AND MONITORING	12
	EDITING ACTIVITIES	13
	<i>Editing Database Driver</i>	13
	<i>Editing Database Info</i>	15
	<i>Editing Database Schema</i>	17
	<i>Editing Mapping</i>	21
	<i>Editing Excel Schema</i>	25
	<i>Testing Excel Schema</i>	27
	<i>Editing File Target</i>	28
	<i>Edit Native Call</i>	30
	CREATING MAPPING ACTIVITY.....	32
	CREATING PROCESS FLOW	54
4	SCRIPTED SERVICE PROCESS FLOW.....	59
	INTRODUCTION	59
	SERVICES USED IN THIS SAMPLE PROCESS FLOW	59
	DESCRIPTION	59
	USAGE SCENARIO	61
	DATA DESCRIPTION	61
	EXECUTING AND MONITORING	61
	EDITING ACTIVITIES	63
	<i>Editing File Source</i>	63
	<i>Editing Scripted Service</i>	65
	<i>Editing Text Schema</i>	67
	<i>Testing Text Schema</i>	69
	<i>Editing Mapping</i>	70
	<i>Editing Excel Schema</i>	72
	CREATING PROCESS FLOW	76
5	PROCESS DESIGNER PROCESS FLOW	85
	INTRODUCTION	85
	SERVICES USED IN THIS SAMPLE PROCESS FLOW	85
	DESCRIPTION	86
	USAGE SCENARIO	87
	DATA DESCRIPTION	87
	PREREQUISITES	88
	EXECUTION AND MONITORING	88

EDITING ACTIVITIES	89
<i>File Source</i>	89
<i>Editing File Target</i>	91
<i>Editing Mail Target</i>	92
CREATING PROCESS FLOW	95
6 PROCESS FLOW TO PROCESS EXCEL DATA	108
INTRODUCTION	108
SERVICES USED IN THIS SAMPLE PROCESS FLOW	108
DESCRIPTION	109
USAGE SCENARIO	111
DATA DESCRIPTION	111
PREREQUISITES	112
USING ANOTHER DATABASE SERVER.....	112
EXECUTION AND MONITORING	112
EDITING ACTIVITIES	115
<i>Editing Mail Events</i>	115
<i>Editing Mail Source</i>	118
<i>Editing Excel Schema</i>	121
<i>Testing Excel Schema</i>	123
<i>Editing Mapping Activity</i>	124
<i>Editing Database Driver</i>	128
<i>Editing Database Info</i>	130
<i>Editing Database Schema</i>	133
<i>Editing Database Target</i>	134
<i>Editing File Target Activity</i>	137
CREATING MAPPING ACTIVITY.....	138
CREATING PROCESS FLOW	154
REGISTERING PROCESS FLOW WITH MAIL EVENTS.....	167
7 JMS EVENT DRIVEN PROCESS FLOW	170
INTRODUCTION	170
SERVICES USED IN THIS SAMPLE PROCESS FLOW	170
DESCRIPTION	170
USAGE SCENARIO	172
DATA DESCRIPTION	172
PREREQUISITES	173
CREATING TABLE INTO DATABASE	174
USING ANOTHER JMS SERVER.....	174
EXECUTING AND MONITORING	174
EDITING ACTIVITIES	178
<i>Editing JMS Provider</i>	178
<i>Editing JMS Event</i>	180
<i>Editing Text Schema</i>	182
<i>Testing Text Schema</i>	185
<i>Editing Mapping</i>	186
<i>Editing Database Driver</i>	188
<i>Editing Database Info</i>	190
<i>Editing Database Schema</i>	193
<i>Editing Database Target</i>	195
CREATING PROCESS FLOW	198
REGISTERING PROCESS FLOW WITH JMS EVENT	204
8 RECORD TO RECORD SERVICE PROCESS FLOW	207

INTRODUCTION	207
SERVICES USED IN THIS SAMPLE PROCESS FLOW	207
DESCRIPTION	207
USAGE SCENARIO	208
DATA DESCRIPTION	208
PREREQUISITES	209
EXECUTING AND MONITORING	209
EDITING ACTIVITIES	211
<i>File Source</i>	211
<i>Editing Positional Schema</i>	212
<i>Testing Positional Schema</i>	214
<i>Editing Record to Record Service</i>	215
<i>Editing JMS Provider</i>	218
<i>Editing JMS Target</i>	219
<i>Editing Mail Notification Activity</i>	221
CREATING PROCESS FLOW	224
9 APPENDIX A: SETTING UP OPENJMS	237
INSTALLING OPENJMS	237
STARTING OPENJMS	238
OPENING OPENJMS	238
10 ABOUT ADEPTIA INC.	241
11 TABLE OF FIGURES	242
12 TABLE OF TABLES	247

1 ABOUT THIS DOCUMENT

Adeptia Suite is shipped with pre-built Process Flows that are based on real business scenarios. This Evaluation Guide describes how to create and run these Process Flows. It provides an overview of these Process Flows, the activities that comprise these Process Flows and the steps describing how to execute these Process Flows.

Pre-Requisite

It is assumed at this point that you have read the **Getting Started Guide** and logged into the Adeptia Suite application.

This document is divided into the following sections:

- **Chapter 1** provides an overview of Adeptia Suite Evaluation Guide.
- **Chapter 2** gives information about the target audience.
- **Chapter 3** describes the *Data Transformation* Process Flow that uses different mapping functions to transform source data into the required format. This process flow is pre-created and is shipped with the Adeptia Suite. This chapter is divided into various sections that describe the Purpose, Services used, Data Description, Pre-requisites, and the Execution Steps separately.
- **Chapter 4** describes the *Scripted Service* Process Flow that demonstrates the use of a scripted service and generation of fDynamic File Name. This process flow is pre-created and is shipped with the Adeptia Suite. This chapter is divided into various sections that describe the Purpose, Services used, Data Description, Pre-requisites, and the Execution Steps separately.
- **Chapter 5** describes the *Process Designer* Process Flow that demonstrates the use of different features of Process Designer. This process flow is pre-created and is shipped with the Adeptia Suite. This chapter is divided into various sections that describe the Purpose, Services used, Data Description, Pre-requisites, and the Execution Steps separately.
- **Chapter 6** describes the *Process Flow to Process Excel Data* that demonstrates the use of different features of process designer and complex mapping functions. This process flow is pre-created and is shipped with the Adeptia Suite. This chapter is divided into various sections that describe the Purpose, Services used, Data Description, Pre-requisites, and the Execution Steps separately.
- **Chapter 7** describes the *JMS Event Driven* Process Flow that demonstrates the use of JMS event for triggering a process flow. This process flow is pre-created and is shipped with the Adeptia Suite. This chapter is divided into various sections that describe the Purpose, Services used, Data Description, Pre-requisites, and the Execution Steps separately.
- **Chapter 8** describes the *Record to Record Service* Process Flow that is used to process data of a positional file. This process flow is pre-created and is shipped with the Adeptia Suite. This chapter is divided into various sections that describe the Purpose, Services used, Data Description, Pre-requisites, and the Execution Steps separately.



Before using the evaluation guide, download and install the Adeptia Suite from our website www.adeptia.com. To know how to install Adeptia Suite, refer to the **Installation Guide**.

2 TARGET AUDIENCE

This document is intended for the users who are evaluating Adeptia Suite and will execute the pre-bundled process flows. It is recommended that you should first read the Getting Started Guide, before reading this guide.

3 DATA TRANSFORMATION PROCESS FLOW

This section describes the Data Transformation Process Flow.

In the Adeptia Suite this process flow is available in:

BPM Suite	Workflow Suite	Integration Suite	ETL Suite
√		√	√

INTRODUCTION

This sample Process Flow demonstrates the use of different mapping function. This Process Flow is used to extract data (Insurance Policy information) from a database source and convert it into an excel format. Conversion of data from database specific format into excel format is done using different mapping functions. After conversion, data is written in an excel file and that excel file is saved into the specified location. At the end of the Process Flow, a native call is used to execute a batch file, which creates a log file. This log file contains the details of the excel file, which is created by the process flow.

SERVICES USED IN THIS SAMPLE PROCESS FLOW

This sample Process Flow illustrates the use of following services of Adeptia Suite:

- Database Driver and Database Info
- Database Schema
- Database Source
- Different Mapping function
- Excel Schema
- File Target
- Native Call

DESCRIPTION

This sample Process Flow can be outlined as below:

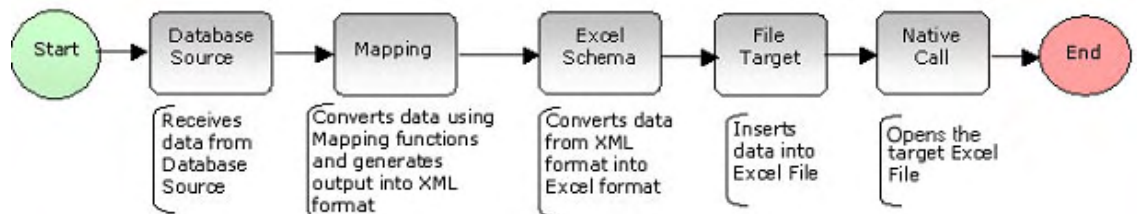

Figure 3.1: Data Transformation Process Flow

Database Source (EvalXform_Source)

Database Source is used to retrieve the data from the database. This contains insurance data for policyholders. Database Source uses Database Schema (EvalXform_DBSchema).

Database Schema (EvalXform_Schema)

Database Schema is used to parse data received from the database and converts it into an intermediate XML format. Database Schema uses Database Driver (EvalXform_DBDriver) and Database Info (EvalXform_DBInfo) to connect to Database Server.

Mapping (EvalXform_Mapping)

Mapping is used to map the data fields of the source data to data fields of the target data. In this Process Flow different mapping functions e.g. Math, String, aggregation and Custom Method are used to manipulate the data.

Excel Schema (EvalXform_ExcelSchema)

Excel Schema is used to convert data from an intermediate XML format to Excel format.

File Target (EvalXform_FileTarget)

File Target is used to specify the name of the target Excel file and the path, where the target excel file is saved.

Native Call (EvalXform_NativeCall)

Native call is used to run native program (e.g. .exe or bat on windows) on the server where Adeptia Suite is running. In this Process Flow, native call executes a batch program (if Adeptia Suite is running on windows) or a shell program (if Adeptia Suite is running on Linux). This program creates a log file which contains the details of the excel file created by the Process Flow.

USAGE SCENARIO

This sample Process Flow can be used whenever you want to transform the data using different mapping functions.

DATA DESCRIPTION AND MAPPING INFORMATION

Data used in this sample Process Flow contains information of insurance policyholders e.g. Name and address of insured person, Premium amount and policy expiration date etc.

The structure of database table used as source is outlined in the table below.

Table 3.1: Structure of Database Table used as Source

Field Name	Description	Data Type
PolicyNumber	Unique number for each policy	Number
NameInsured	Name of the insured person	String
Address	Address of the insured person	String
DOB	Date of Birth of insured Person	Date
TelephoneNo	Contact no. of the insured person	Number
ExpiryDate	Expiry date of the policy	Date
PremiumMedical	Premium amount for medical insurance	Number
PremiumDental	Premium amount for dental insurance	Number
SecurityCode	Secret Code used to verify the insured person	Number

The structure of Excel File used as target and mapping information is outlined in the table below.

Table 3.2: Structure of Excel Table used as Target

Field Name	Description	Data Type
SerialNo.	Serial Number of the source record. Position function is used to calculate the Serial Number.	Number
PolicyNumber	Unique number for each policy	Number
NameInsured	Name and address of the insured person, Concat function is used between NameInsured and Address field of source	String
Age	Age of the insured person, Custom Method is used to call a java class, which calculates age based on DOB of insured person	Number
TelephoneNo	Contact no. of the insured person	String
ExpiryDate	Expiry date of the policy, record of already expired policy is not shown.	String
Premium	Sum of PremiumMedical and PremiumDental. Math function is used to add PremiumMedical and PremiumDental of source record	Number

PREREQUISITES

- Data records must be present in database server used as source.

	To know, how to populate the records into your database, refer to Populating Data into Database section.
---	--

- Before executing this process flow, you must edit the following activities to point to the database which is used as source:
 - EvalXform_DBDriver
 - EvalXform_DBInfo

To know, how to edit these activities refer to [Editing Activities](#) section.

POPULATING DATA INTO DATABASE

In this process flow, a database table is used as source. A SQL script is provided with Adeptia Suite to create a table in your database and populate data (used as source) into this table. This SQL script is located in *../AdeptiaServer-5.0/Serverkernel/Solutions/Demo/EvalXform* folder. To create table and populate data into your source database, you need to run the respective SQL Script, using the database client application.

EXECUTING AND MONITORING

This section describes the execution of sample Process Flow and monitoring Process Flow execution.

Steps to execute the Process Flow

1. In the Adeptia Suite homepage menu, click **[+] Design** to expand the tree. All the items in the **Design** category are displayed.
2. Click **[+] Process Flow** to expand the tree and then click **Process Flow**. The Manage Process Flow screen is displayed.
3. Select the radio button adjacent to *EvalXform_ProcessFlow* and then click **Execute** link. The View Process Flow Log screen is displayed (see Figure 3.2).

Request submitted for [EvalXform_ProcessFlow](#) execution at [Wed Sep 23 16:01:20 IST 2009](#).
See the [Process Flow Logs](#) for execution details.

Figure 3.2: View Process Flow Monitor

4. Click the link **Process Flow Logs** to view the status of the Process Flow execution. The Process Flow Logs is displayed (see Figure 3.3).

Refresh View Process flow log						
Activity Name	Activity Type	Status	UserID	Start Time	End Time	Action
EvalXform_ProcessFlow	Transaction	Running	admin	09/07/2010 12:59:04	NA	Details Diagnostics

Figure 3.3: Process Flow Logs

5. Click **Details** under the **Action** column of the activity of which you want to view execution details. This displays the Detailed Process Flow Activity Execution screen (see Figure 3.4).

Process Flow Log Details						
Process Flow Name : EvalXform_ProcessFlow Process Flow PID : 12700000001119104738914000028						
Date/Time	Activity Name	Activity Type	Status	Message	Level	Location
09/29/2007 11:59:53	EvalXform_ProcessFlow	Transaction	Executed	Activity disposed. Start Time:2007-09-29 11:59:49 End Time:2007-09-29 11:59:53 Run Time:3 second(s) 828 ms	INFO	services.AbstractService(AbstractService.java
09/29/2007 11:59:53	EvalXform_ProcessFlow	Transaction	Running	Context Information: {TransactionAddress=localhost://indigo.Transaction[192168001166112203049331200004]12700000001119104738914000028};type=Transaction.name=EvalXform_ProcessFlow.id=192168001166112203049331200004.pId=12700000001119104738914000028.currentState=state-BPMN:TASK:BASIC_TASK-1130736.LoggingLevel=INFO}	INFO	services.AbstractService(AbstractService.java
09/29/2007 11:59:53	EvalXform_NativeCall	NativeCall	Running	Executable ./../Sample Datafiles/EvalXform/EvalXform_OpenFile.bat called	INFO	services.nativeservice.Nativeservice.execute(Nativeservice.java:206)
09/29/2007 11:59:53	EvalXform_NativeCall	NativeCall	Executed	Activity disposed. Start Time:2007-09-29 11:59:52 End Time:2007-09-29 11:59:53 Run Time:110 ms	INFO	services.AbstractService(AbstractService.java
09/29/2007 11:59:52	EvalXform_NativeCall	NativeCall	Running	Initialize	INFO	services.AbstractService(AbstractService.java
09/29/2007 11:59:52	EvalXform_FileTarget	FileTarget	Executed	Activity disposed. Start Time:2007-09-29 11:59:52 End Time:2007-09-29 11:59:52 Run Time:47 ms. Operation count:13824 Bytes Average:294127.66 operations/sec	INFO	services.AbstractService(AbstractService.java
09/29/2007 11:59:52	EvalXform_FileTarget	FileTarget	Running	Initialize	INFO	services.AbstractService(AbstractService.java
09/29/2007 11:59:52	EvalXform_FileTarget	FileTarget	Running	Execute	INFO	services.AbstractService(AbstractService.java
09/29/2007 11:59:52	EvalXform_ExcelSchema	XmlStream2StreamTransformer	Executed	Activity disposed. Start Time:2007-09-29 11:59:51 End Time:2007-09-29 11:59:52 Run Time:1 second(s) 31 ms. Operation count:3 Records Average:2.9097962 operations/sec	INFO	services.AbstractService(AbstractService.java
09/29/2007 11:59:51	EvalXform_ExcelSchema	XmlStream2StreamTransformer	Running	Execute	INFO	services.AbstractService(AbstractService.java

Figure 3.4: Process Flow Log Details

- After the process flow is executed successfully, you can view the log file (EvalXform_OpenFile.log), which is created by the Native call activity.
- This log file created in **../AdeptiaServer-5.0/Serverkernel/Solutions/Demo/EvalXform** folder on server, where Adeptia Suite is running.

EDITING ACTIVITIES

Activities used in this sample Process Flow are pre-created. This section describes the process of editing these activities.

Editing Database Driver

(EvalXform_DBDriver)

Database Driver is used to specify the type of database and to upload driver jar files required to connect to that database.

Steps to edit Database Driver

- In the Adeptia Suite homepage menu, click **[+] Configure** to expand the tree. All the items in the **Configure** category are displayed.
- Click **[+] Services** to expand the tree and then click **[+] Connector**. All the items in the **Connector** category are displayed.
- Click **Database Driver**. The Manage Database Driver screen is displayed with the list of existing database drivers.
- Select the radio button adjacent to *EvalXform_DBDriver* activity and then click **Edit** link. This displays the Edit *EvalXform_DBDriver* activity, with the properties of the activity displayed in their respective fields (see Figure 3.5).

Configure > Services > Connector > Database Driver > SQLServer_DBDriver

[-] Standard properties

Name *	SQLServer_DBDriver	
Description *	SQL server driver	
Upload Driver Jar/Zip files	jtds-1.2.jar	Browse Jars
Driver Main Class Name *	net.sourceforge.jtds.jdbc.Driver	Get Driver Class...

[+] Advanced properties

* Mandatory fields.

[Save](#)
[Save As](#)
[Cancel](#)

Figure 3.5: Edit *EvalXForm_DBDriver*

A detailed description of fields on this screen is explicated in the table below.

Table 3.3: Details of Fields on Edit Database Driver Screen

Field Name	Field Description										
Name	Name of the Database Driver										
Description	Description of the Database Driver										
Upload Driver Jar Files	<p>JDBC Driver files, which are used to connect Database Server. Click the Browse Jars button to select Jar files. Following is the list of databases and the required Jar files:</p> <table style="width: 100%; border-collapse: collapse; margin-top: 5px;"> <tr> <td style="padding: 2px 10px;">Oracle</td> <td style="padding: 2px 10px;">OJDBC5.jar</td> </tr> <tr> <td style="padding: 2px 10px;">IBM DB2 (Ver 7.1)</td> <td style="padding: 2px 10px;">db2java.zip (7.1 version)</td> </tr> <tr> <td style="padding: 2px 10px;">IBM DB2 (Ver 8.1)</td> <td style="padding: 2px 10px;">db2jcc.jar</td> </tr> <tr> <td style="padding: 2px 10px;">JTDS- SQL Server</td> <td style="padding: 2px 10px;">Jtds.jar</td> </tr> <tr> <td style="padding: 2px 10px;">HSQL DB</td> <td style="padding: 2px 10px;">hsqldb-1.8.0.7.jar</td> </tr> </table>	Oracle	OJDBC5.jar	IBM DB2 (Ver 7.1)	db2java.zip (7.1 version)	IBM DB2 (Ver 8.1)	db2jcc.jar	JTDS- SQL Server	Jtds.jar	HSQL DB	hsqldb-1.8.0.7.jar
Oracle	OJDBC5.jar										
IBM DB2 (Ver 7.1)	db2java.zip (7.1 version)										
IBM DB2 (Ver 8.1)	db2jcc.jar										
JTDS- SQL Server	Jtds.jar										
HSQL DB	hsqldb-1.8.0.7.jar										
Driver Main Class Name	<p>Driver Main Class Name is a fully qualified java class name for the main database driver class. The driver class name typically starts with a com., net. or org. followed by the company domain, for example the JDBC driver class from mysql.com is called com.mysql.jdbc.Driver. Click the Help button to select Driver Main Class Name from the drop-down list. Following is the list of Driver Main Class Name of different databases:</p>										

	Oracle	oracle.jdbc.driver.OracleDriver
	IBM DB2 (Ver 7.1)	COM.ibm.db2.jdbc.net.DB2Driver
	IBM DB2 (Ver 8.1)	com.ibm.db2.jcc.DB2Driver
	JTDS-SQL Server	net.sourceforge.jtds.jdbc.Driver
	HSQLDB	org.hsqldb.jdbcDriver
	MS Access	sun.jdbc.odbc.JdbcOdbcDriver
	MS Excel	sun.jdbc.odbc.JdbcOdbcDriver

5. Make the necessary changes.
6. Once you have made the required changes, click the **Save** button to save the changes. A screen is displayed confirming that the Database Driver has been updated successfully. If the *comments* property is enabled, then clicking **Save** will display a screen where you need to enter comments related to updating the database driver (refer to Figure 7.10).
7. Enter the comments in the *Add Comments* field.

	The comment should be at least 1 character in length.
---	---

8. Click **OK** to save the comments. This displays a screen confirming that the database driver has been updated successfully.

Editing Database Info (EvalXform_DBInfo)

Database Info activity is used to specify the JDBC URL or Server URL and the Username and Password to access the database. Database Info uses Database Info to connect to the specified Database Server.

Steps to edit the Database Information

1. In the Adeptia Suite homepage menu, click **[+] Configure** to expand the tree. All the items in the **Configure** category are displayed.
2. Click **[+] Services** to expand the tree and then click **[+] Connector**. All the items in the **Connector** category are displayed.
3. Click **Database Info**. The Manage Database Info screen is displayed with the list of existing Database Info.
4. Select the radio button adjacent to *EvalXform_DBInfo* activity and then click **Edit** link. This displays the Edit *EvalXform_DBInfo* activity screen, with the properties of the activity displayed in their respective fields (see Figure 3.6).

Configure > Services > Connector > Database Info > EvalXform_DbInfo

[-] Standard properties

Name *

Description *

Select JDBC Driver*

Use Existing

Create New

Server URL *

User *

Password

Confirm Password

[+] Advanced properties

* Mandatory fields.

Figure 3.6: Edit *EvalXForm_DbInfo*

A detailed description of fields on this screen is explicated in the table below.

Table 3.4: Details of Fields on Edit Database Info Screen

Field Name	Field Description								
Name	Name of the Database Info								
Description	Description of the Database Info								
JDBC Driver	Database Driver is created to connect to the database Server. For more details refer to section Editing Database Driver . You can use an existing driver or create a new database driver.								
Server URL	<p>Server URL or JDBC URL points to a specific database on a specified database server. There is no standard for JDBC URL. Every JDBC driver uses a slightly different syntax. For Example a JDBC URL for a MySQL database using the <code>com.mysql.jdbc.Driver</code> direct from MySQL might look like this:</p> <p><code>jdbc:mysql://localhost/databaseName.</code> To specify Server URL, Click the Help button and enter the following information:</p> <table border="0"> <tr> <td>Database Type</td> <td>Type of the database</td> </tr> <tr> <td>Host Name</td> <td>Name of the server on which database server is running</td> </tr> <tr> <td>Port</td> <td>Port at which database server is running</td> </tr> <tr> <td>Database Name</td> <td>Name of the database</td> </tr> </table> <p>Following is the list of Server URL's of different databases:</p>	Database Type	Type of the database	Host Name	Name of the server on which database server is running	Port	Port at which database server is running	Database Name	Name of the database
Database Type	Type of the database								
Host Name	Name of the server on which database server is running								
Port	Port at which database server is running								
Database Name	Name of the database								

Oracle	jdbc:oracle:thin:@databaseserver:1521:orcl
IBM DB2 (Ver 7.1)	jdbc:db2://databaseserver:6789/TOOLSDB
IBM DB2 (Ver 8.1)	jdbc:db2://databaseserver:50000/TOOLSDB
SQL JTDS	jdbc:jtds:sqlserver://databaseserver:1433/master
MS Access	jdbc:odbc:Driver={Microsoft Access Driver (*.mdb)}; DBQ=c:/test/db1.mdb
MS Excel	Jdbc:odbc:ExcelJDBCtest where <i>ExcelJDBCtest</i> is the ODBC object that you need to create using DSN.
HSQL DB	jdbc:hsqldb:hsqldb://databaseserver:2476
Here database server is the name of the server where database is running.	

5. Make the necessary changes.
6. Once you have made the required changes, click the **Save** button to save the changes. A screen is displayed confirming that the Database Info has been updated successfully. If the *comments* property is enabled, then clicking **Save** will display a screen where you need to enter comments related to updating the Database Info (refer to Figure 7.10).
7. Enter the comments in the *Add Comments* field.

	The comment should be at least 1 character in length.
---	---

8. Click **OK** to save the comments. This displays a screen confirming that the Database Info has been updated successfully.

Editing Database Schema

(EvalXform_DBSchema)

Database Schema defines the structure of the database table. A Database Schema is used to define how records can be read from a database table or can be written into a database table. In this sample process Database Schema is being used at the source end. At the source end it converts data from database specific format into an intermediate XML format. Database Schema uses Database Info activity to connect to the database Server. It should be noted that the Database Schema does not directly take part in creation of Process Flow. It is used by the Database Source activity and the Database Source activity is used in the Process Flow.

Steps to edit the Database Schema activity

1. In the Adeptia Suite homepage menu, click **[+] Configure** to expand the tree. All the items in the **Configure** category are displayed.

2. Click **[+] Services** to expand the tree. All the items in the **Services** category are displayed.
3. Click **[+] Schema** to expand the tree, and then click **Database**. The Manage Database Schema screen is displayed with a list of existing Database schemas.
4. Select the radio button adjacent to *EvalXform_DbSchema* activity and then click **Edit** link. This displays the Edit *EvalXform_DbSchema* activity screen, with the properties of the activity displayed in their respective fields (see Figure 3.7).

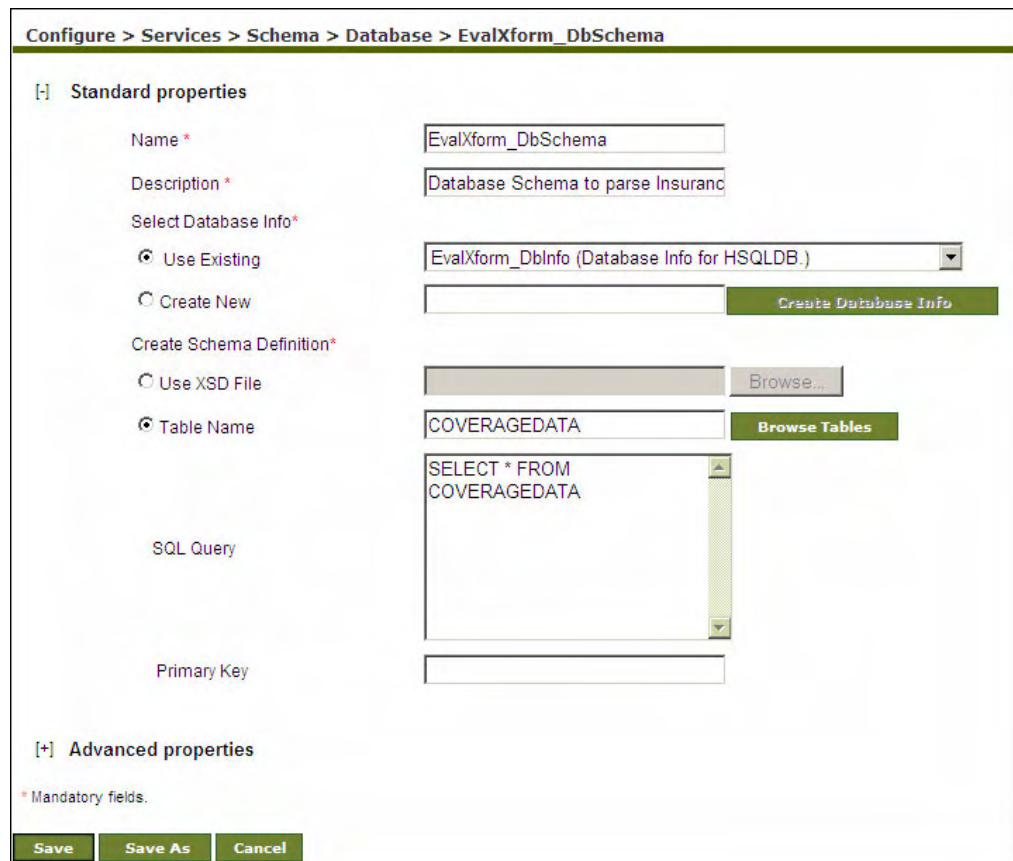

Figure 3.7: Edit *EvalXForm_DbSchema* Activity

A detailed description of fields on this screen is explicated in the table below.

Table 3.5: Details of Fields on Edit Database Schema Screen

Field Name	Field Description
Name	Name of the Database Schema
Description	Description of the Database Schema
Database Info	Database Info created to connect to the specified Database Server. For more details refer to Editing Database Info section. You can use an existing Database Info activity or create a new one.

Create Schema Definition	<p>Schema Definition can be created using one of the following options:</p> <ul style="list-style-type: none"> ▪ Use XSD File ▪ Table Name <p>Database Schema used in this Process Flow is created using second option i.e. Table Name. To select database tables, select Table Name radio button and then Click the Browse Tables. <i>Select Table</i> screen is displayed with the list of database Table. Select the required table and click Get Columns button. Click Close button to close the <i>Select Table</i> screen and return to Database Schema screen.</p> <p>SQL Query box automatically gets populated after selecting database tables.</p>
--------------------------	--

9. Make the necessary changes.
10. Once you have made the required changes, click the **Save** button to save the changes. A screen is displayed confirming that the Database Schema has been updated successfully. If the *comments* property is enabled, then clicking **Save** will display a screen where you need to enter comments related to updating the database schema (refer to Figure 7.10).
11. Enter the comments in the *Add Comments* field.

	The comment should be at least 1 character in length.
--	---

12. Click **OK** to save the comments. This displays a screen confirming that the database schema has been updated successfully.

Editing Database Source

(EvalXform_DBSource)

Database Source is used to insert data into a database server. Database Source uses Database Info for Server URL and login information, and Database Schema to get information for database tables and data type etc.

Steps to edit the Database Source

1. In the Adeptia Suite homepage menu, click **[+] Configure** to expand the tree. All the items in the **Configure** category are displayed.
2. Click **[+] Services** to expand the tree. All the items in the **Services** category are displayed.
3. Click **[+] Source** to expand the tree, and then click **Database**. The Manage Database Source screen with the list of existing Database Source activities is displayed (see Figure 3.8).

Configure > Services > Source > Database					
New Edit Delete Revisions Dependencies					
--Select Field to Search--					Search
#	Name	Description	Owner	Perm.	Modified
1	<input type="radio"/> EvalXform_DBSource	Database Source having insurance data	demouser	RWX	07/22/05 16:27

Figure 3.8: Manage Database Source

4. Select the radio button adjacent to *EvalXform_DBSource* activity and then click **Edit** link. This displays the Edit *EvalXform_DBSource* activity screen, with the properties of the activity displayed in their respective fields (see Figure 3.9).

Configure > Services > Source > Database > EvalXform_DBSource	
[-] Standard properties	
Name *	<input type="text" value="EvalXform_DBSource"/>
Description *	<input type="text" value="Database Source having insurance d"/>
Database Info *	<input type="text" value="EvalXform_DbInfo (Database Info for HSQLDB.)"/>
Schema Name *	<input type="text" value="EvalXform_DbSchema (Database Schema to parse...)"/>
[+] Advanced properties	
* Mandatory fields.	
<input type="button" value="Save"/> <input type="button" value="Save As"/> <input type="button" value="Cancel"/>	

Figure 3.9: Edit *EvalXForm_DBSource* Activity

A detailed description of fields on this screen is explicated in the table below.

Table 3.6: Details of Fields on Edit Database Source Screen

Field Name	Field Description
Name	Name of the Database Source
Description	Description of the Database Source
Database Info	Database Info created to connect to the specified Database Server. For more details refer to Editing Database Info section.
Schema Name	Database Schema, which describes the structure of database table. For more details refer to Editing Database Schema section.

5. Make the necessary changes.
6. Once you have made the required changes, click the **Save** button to save the changes. A screen is displayed confirming that the Database Source has been updated successfully. If the *comments* property is enabled, then clicking **Save** will display a screen where you need to enter comments related to updating the database schema (refer to Figure 7.10).
7. Enter the comments in the *Add Comments* field.



The comment should be at least 1 character in length.

- Click **OK** to save the comments. This displays a screen confirming that the database schema has been updated successfully.

Editing Mapping (EvalXform_Mapping)

Mapping is used to map data fields of the source Schema with the data fields of the target Schema. In this sample Process Flow, advanced mapping functions e.g. Math, String, Aggregation and Custom Method are used.

Steps to edit the Mapping activity

- In the Adeptia Suite homepage menu, click **[+] Configure** to expand the tree. All the items in the **Configure** category are displayed.
- Click **[+] Services** to expand the tree. All the items in the **Services** category are displayed.
- Click **[+] Data Transform** to expand the tree, and then click **Data Mapping**. The Manage Data Mapping screen is displayed with the list of existing mapping activities (refer to Figure 7.15).
- Select the radio button adjacent to *EvalXform_Mapping* activity and then click **Edit** link. This displays the Edit *EvalXform_Mapping* activity screen with the name and description of the activity displayed in their respective fields (see Figure 3.10).

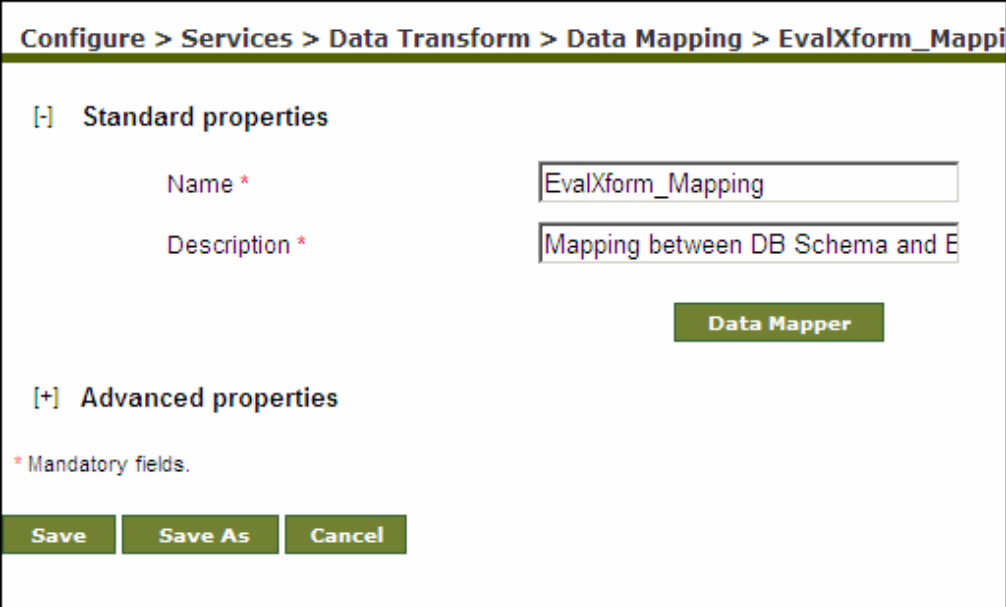

Configure > Services > Data Transform > Data Mapping > EvalXform_Mapping

[-] Standard properties

Name *

Description *

Data Mapper

[+] Advanced properties

* Mandatory fields.

Save Save As Cancel

Figure 3.10: Edit *EvalXForm_Mapping* Activity

- Click **Data Mapper** button. The Data Mapper applet is displayed showing mapping between data fields of source and target schema (see Figure 3.11).

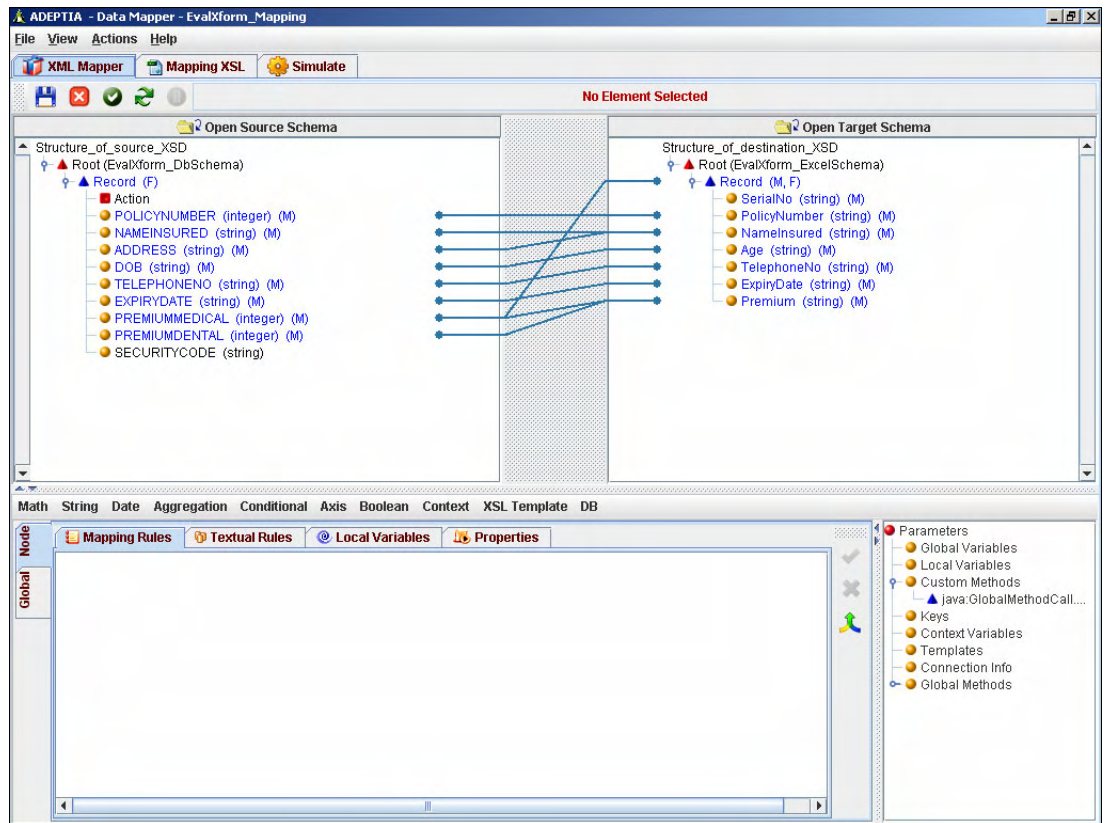

Figure 3.11: *EvalXForm_Mapping* Activity in the Data Mapper Applet

- To view how mapping function is used, click any of the target elements (*Record*) in the Target Panel. The mapping function used for the selected element is displayed in the Mapping Graph Area (see Figure 3.12).

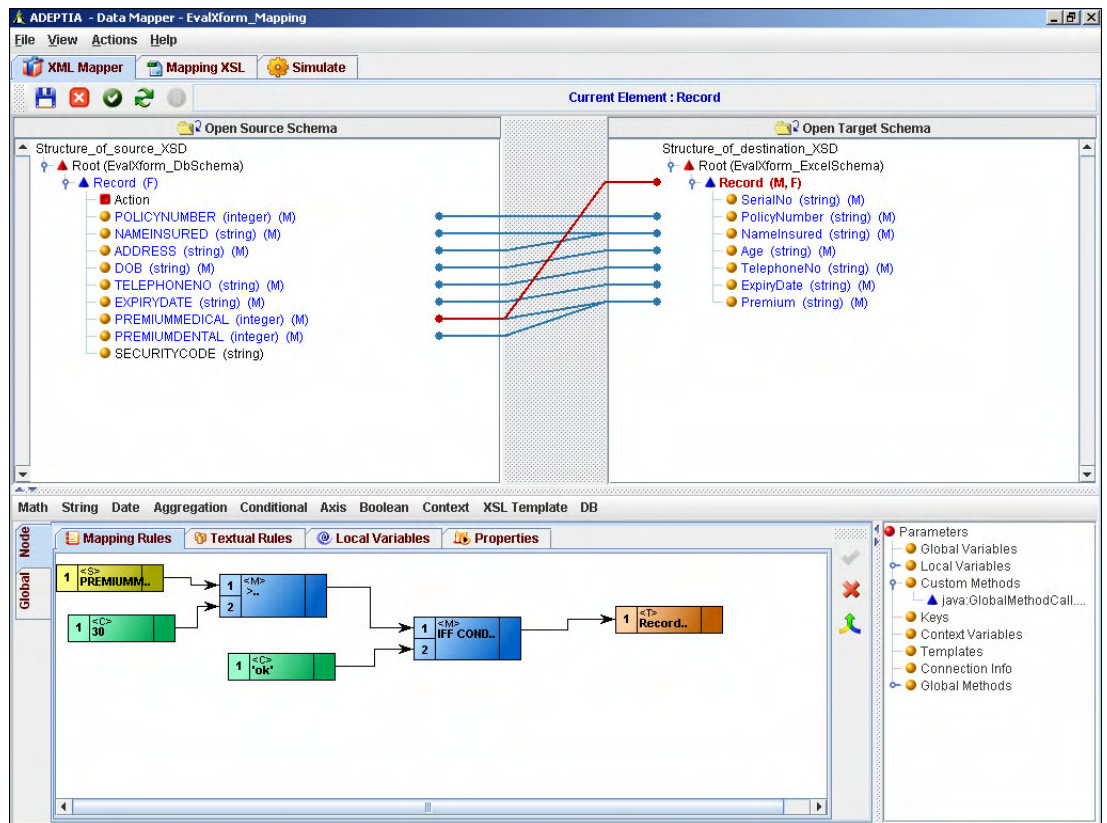

Figure 3.12: View Mapping Functions used in *EvalXForm_Mapping* Activity

7. To analyze the impact of mapping function on output records, right-click any of function node (*IFF Condition*) and select **Information** (see Figure 3.13).

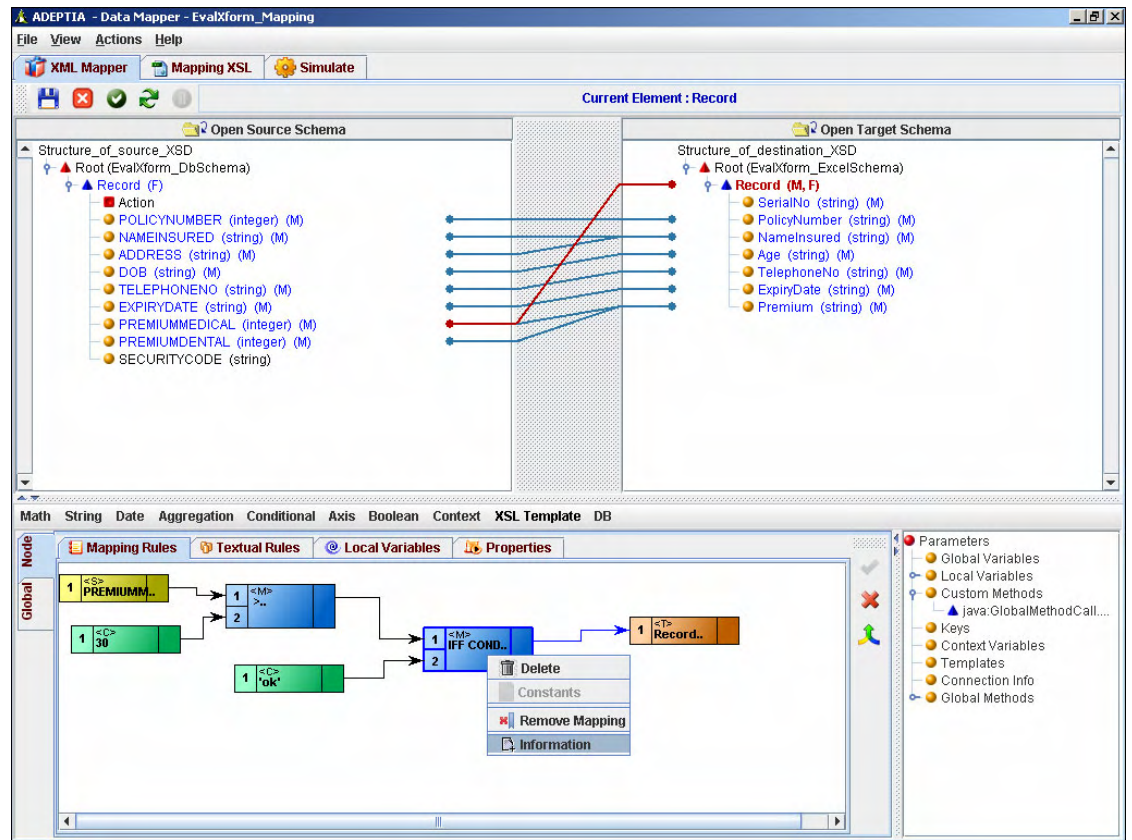

Figure 3.13: Select Mapping Function Information

8. A dialog box is displayed that shows the information about that mapping function (see Figure 3.14).

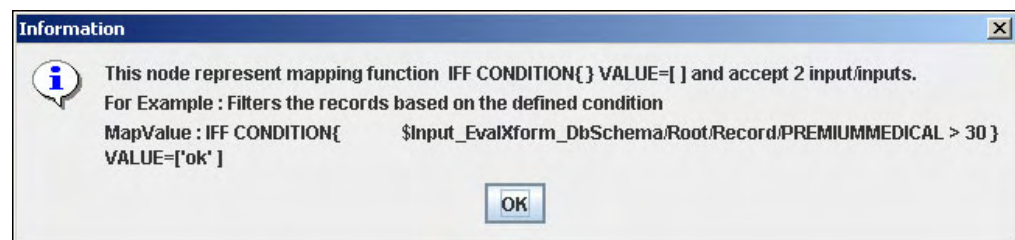





Figure 3.14: View Mapping Function Information

9. Click **OK** to close the dialog box.
10. Make the necessary changes to the mapping between the source and target data fields.
11. Once you have made the required changes, save the mapping by clicking **File** menu and selecting **Save**. A dialog box is displayed confirming that the mapping activity has been saved successfully.

 Alternately, you can save the mapping by clicking **Save** () button on the Tool Bar.

12. If the *comments* property is enabled, then clicking **Save** will display a screen where you need to enter comments related to the mapping (refer to Figure 7.18).
13. Enter the comments in the *Specify comments for mapping object (object name)* field.

 The comment should be at least 1 character in length.

14. Click **OK** to save the comments. This displays a dialog box confirming that the mapping has been saved successfully.
15. Exit the Data Mapper applet by clicking **File** menu and selecting **Exit**.

 To know, how this mapping activity has been created, refer to [Creating Mapping Activity](#) section.

Editing Excel Schema (EvalXform_ExcelSchema)

Excel Schema defines the structure of Excel file. Excel Schema defines how the data can be read from an excel sheet or how it can be written into an excel sheet. In this sample Process Flow, Excel schema is used at the target end. At target end Excel Schema converts the data from an intermediate XML format into Excel format.

Steps to edit the Excel Schema activity

1. In the Adeptia Suite homepage menu, click **[+] Configure** to expand the tree. All the items in the **Configure** category are displayed.
2. Click **[+] Services** to expand the tree. All the items in the **Services** category are displayed.
3. Click **[+] Schema** to expand the tree, and then click **Excel**. The Manage Excel Schema screen is displayed with the list of existing Excel Schemas (see Figure 3.15).

Configure > Services > Schema > Excel

New | Edit | Delete | Revisions | Dependencies --Select Field to Search--

#	Name	Description	Owner	Perm.	Modified
1	<input type="radio"/> OrderFulfillmentExcelSchema	schema definition of order file	demouser	RWX	08/07/09 12:24
2	<input type="radio"/> EmployeeBenefitsExcelSchema	schema definition of benefit file	demouser	RWX	08/07/09 12:24
3	<input type="radio"/> EvalScript_ExcelSchema	Excel Schema for employee record	demouser	RWX	08/12/06 15:36
4	<input type="radio"/> EvalXform_ExcelSchema	Excel Schema	demouser	RWX	08/09/05 17:15
5	<input type="radio"/> EvalPF_ExcelSchema_Format2	excel schema format 2	demouser	RWX	07/21/05 15:37
6	<input type="radio"/> EvalPF_ExcelSchema_Format1	excel schema format 1	demouser	RWX	07/21/05 15:36

Figure 3.15: Manage Excel Schema

- Select the radio button adjacent to *EvalXform_ExcelSchema* activity and then click **Edit** link. This displays the Edit *EvalXform_ExcelSchema* activity screen, with the properties of the activity displayed in their respective fields (see Figure 3.16).

Configure > Services > Schema > Excel > EvalXform_ExcelSchema

[-] Standard properties

Name *

Description *

Data Header Present

Download Schema Definition File

Create Schema Definition*

Use Definition File

Enter the Fields Sequentially

Sheet Name*

#	FieldName	Type	Format	SubFormat	Data Mode
1	<input type="text" value="SerialNo"/>	string	mmddyyyy	hh:mm:ss	Plain Text
2	<input type="text" value="PolicyNumber"/>	string	mmddyyyy	hh:mm:ss	Plain Text
3	<input type="text" value="NameInsured"/>	string	mmddyyyy	hh:mm:ss	Plain Text
4	<input type="text" value="Age"/>	string	mmddyyyy	hh:mm:ss	Plain Text

Number of Rows at Position

Define Hierarchy

[+] Advanced properties

* Mandatory fields.

Figure 3.16: Edit *EvalXForm_ExcelSchema* Activity

A detailed description of fields on this screen is explicated in the table below.

Table 3.7: Details of Fields on Edit Excel Schema Screen

Field Name	Field Description								
Name	Name of the Excel Schema								
Description	Description of the Excel Schema								
Data Header Present	Data Header usually contains the titles of the fields in a file. If you enable this option, Field Names of Excel Schema are written as column's name in target excel file								
Sheet Name	Name specified here becomes the Book Name of the excel sheet.								
Create Schema Definition	Schema can be defined using one of the following options: <ul style="list-style-type: none"> ▪ Use Definition File ▪ Enter the Field Sequentially Pre-created schema with this sample Process Flow is created using second option i.e. Enter the Field Sequentially								
Field Name	Name of the Fields								
Type	There are three data types: <table border="0" style="width: 100%;"> <tr> <td style="width: 20%;">String</td> <td>String can be used for any type of data.</td> </tr> <tr> <td>Number</td> <td>Contains numbers</td> </tr> <tr> <td>Date</td> <td>Contains Date and Time</td> </tr> <tr> <td>Currency</td> <td>Contains Currency Value</td> </tr> </table>	String	String can be used for any type of data.	Number	Contains numbers	Date	Contains Date and Time	Currency	Contains Currency Value
String	String can be used for any type of data.								
Number	Contains numbers								
Date	Contains Date and Time								
Currency	Contains Currency Value								
Format	If data type is <i>Date</i> , select the data format from <i>Format</i> drop-down list.								
SubFormat	If data type is <i>Date</i> , select time format from <i>SubFormat</i> drop-down list.								
Data Mode	If data is in Plain Text, select <i>Plain Text</i> option. If data is encrypted, then select <i>Encrypted</i> option.								

10. Make the necessary changes.
11. Once you have made the required changes, click the **Save** button to save the changes. A screen is displayed confirming that the Excel Schema has been updated successfully. If the *comments* property is enabled, then clicking **Save** will display a screen where you need to enter comments related to updating the excel schema (refer to Figure 7.10).
12. Enter the comments in the *Add Comments* field.

	The comment should be at least 1 character in length.
---	---

13. Click **OK** to save the comments. This displays a screen confirming that the excel schema has been updated successfully.

Testing Excel Schema

(EvalXForm_ExcelSchema)

You can verify the excel schema activity at design time.

Steps to verify schema activity

1. Click **Test** button on the Edit Excel Schema screen. The Test Schema screen is displayed (refer to Figure 7.14).
2. Select the type of schema to test, from the *Type* drop-down list. By default, *Source* is selected. Since this Excel schema is used at target end, select Target from *Type* drop-down list.
3. Enter the full path of the XML file generated by EvalXForm_Mapping activity, in the *Source File Name* field.
4. Enter the full path (with file name) of the target file, where it will be generated, in the *Target File Name* field.
5. Enter the full path of the XML file where errors will be stored, in the *Error File Name* field.
6. Click **Submit** button. This tests the validity of the excel schema.

Editing File Target (EvalXform_FileTarget)

File target is used to specify the name of the target file and path, where the target file is saved. In this sample Process Flow, target file is saved in `../../AdeptiaServer-5.0/Sample Datafiles/EvalXform` directory.

Steps to edit the File Target:

1. In the Adeptia Suite homepage menu, click **[+] Configure** to expand the tree. All the items in the **Configure** category are displayed.
2. Click **[+] Services** to expand the tree. All the items in the **Services** category are displayed.
3. Click **[+] Target** to expand the tree, and then click **File**. The Manage File Target screen is displayed with the list of existing File Target activities (see Figure 3.17).

Configure > Services > Target > File						
New Edit Delete Revisions Dependencies					--Select Field to Search--	Search
#	Name	Description	Owner	Perm.	Modified	
1	<input type="radio"/> InventoryItemsTarget	output XML location	demouser	RWX	11/24/09 14:24	
2	<input type="radio"/> EmployeeBenefitTarget	output XML file location	demouser	RWX	11/24/09 14:24	
3	<input type="radio"/> EvalScript_FileTarget	File Target for Appended Employee Records	demouser	RWX	11/24/09 14:24	
4	<input type="radio"/> EvalPF_FileTarget_ErrorRecord	Erroneous records in input excel	demouser	RWX	11/24/09 14:23	
5	<input type="radio"/> EvalPF_FileTarget_UpdateError	Erroneous records found while updating records in database2	demouser	RWX	11/24/09 14:23	
6	<input type="radio"/> EvalPF_FileTarget_InsertError	Erroneous records found while inserting records in database1	demouser	RWX	11/24/09 14:23	
7	<input type="radio"/> EvalXform_FileTarget	excel file target	demouser	RWX	11/24/09 14:23	
8	<input type="radio"/> EvalPD_FileTarget	file target with purchase order	demouser	RWX	11/24/09 14:23	

Figure 3.17: Manage File Target

4. Select the radio button adjacent to *EvalXform_FileTarget* activity and then click **Edit** link. This displays the Edit *EvalXform_FileTarget* activity screen, with the properties of the activity displayed in their respective fields (see Figure 3.18).

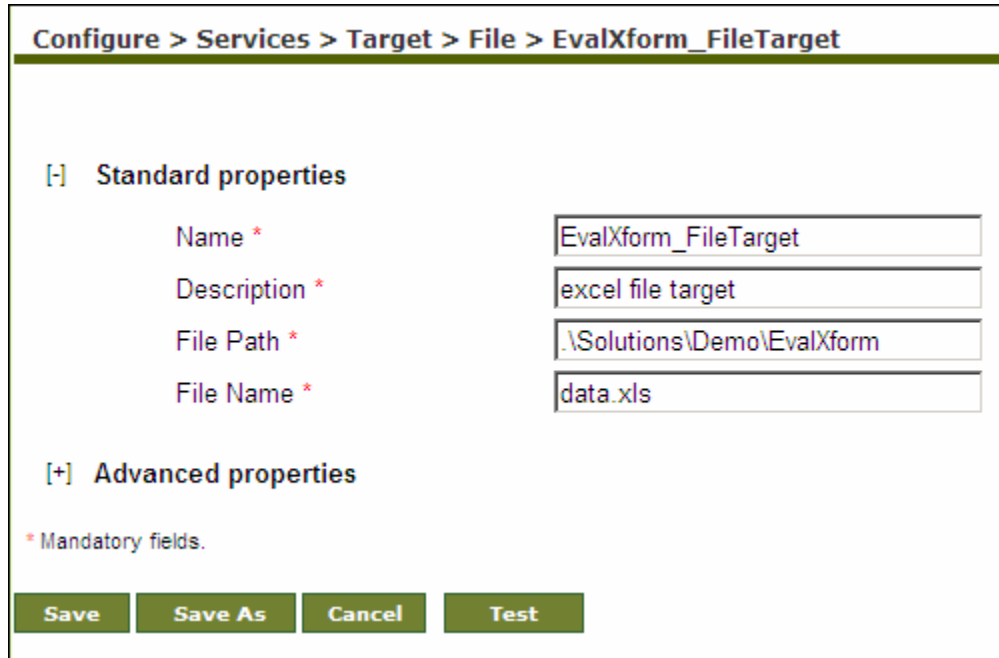



Figure 3.18: Edit *EvalXForm_FileTarget* Activity

A detailed description of fields on this screen is explicated in the table below.

Table 3.8: Details of Fields on Edit File Target Screen

Field Name	Field Description
Name	Name of the File Target
Description	Description of the File Target
File Path	Path of the target file. For example: <code>../../Solutions/Demo/EvalXform/</code>
File Name	Name of the target file. For example: data.xls

5. Make the necessary changes.
6. Once you have the made the required changes, click the **Save** button to save the changes. A screen is displayed confirming that the File Target Activity has been updated successfully. If the *comments* property is enabled, then clicking **Save** will display a screen where you need to enter comments related to updating the file target (refer to Figure 7.10).
7. Enter the comments in the *Add Comments* field.

The comment should be at least 1 character in length.

8. Click **OK** to save the comments. This displays a screen confirming that the file target has been updated successfully.



You can verify the file target activity at design time. For this, click **Test Connection**. This verifies the values in the *File Name* and *File Path* field and checks whether the file actually exists in the specified location.

Edit Native Call (EvalXform_NativeCall)

Native call is used to run any .bat, .exe or .sh file at any point during the execution of a Process Flow. In this sample Process Flow, Native Call is used to run a .bat file, which opens the Target Excel file created after the execution of the Process Flow.

Steps to edit the Native Call:

1. On the Adeptia Suite homepage menu, click **[+] Configure** to expand the tree. All the items in the **Configure** category are displayed.
2. Click **[+] Services** to expand the tree. All the items in the **Services** category are displayed.
3. Click **[+] Extension** to expand the tree, and then click **Native Call**. The Manage Native Call screen is displayed with the list of existing Native Calls (see Figure 3.19).

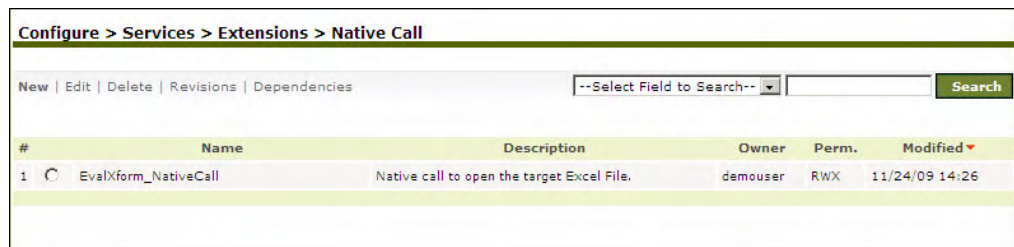

Configure > Services > Extensions > Native Call					
New Edit Delete Revisions Dependencies				--Select Field to Search--	Search
#	Name	Description	Owner	Perm.	Modified
1	EvalXform_NativeCall	Native call to open the target Excel File.	demouser	RWX	11/24/09 14:26

Figure 3.19: Manage Native Call

4. Select the radio button adjacent to *EvalXform_NativeCall* activity and then click **Edit** link. This displays the Edit *EvalXform_NativeCall* activity screen, with the properties of the activity displayed in their respective fields (see Figure 3.20).

Configure > Services > Extensions > Native Call > EvalXform_NativeCall

[-] Standard properties

Name *	<input type="text" value="EvalXform_NativeCall"/>
Description *	<input type="text" value="Native call to open the target Excel F"/>
Default Extension	<input type="text" value="Select Extension"/>
File Name(Absolute Path) *	<input type="text" value="/Solutions/Demo/EvalXform/EvalXfor"/>
Argument(s) space separated	<input type="text"/>
Working Directory(Absolute Path)	<input type="text"/>

[+] Advanced properties

* Mandatory fields.

Save
Save As
Cancel

Figure 3.20: Edit *EvalXForm_NativeCall* Activity

A detailed description of fields on this screen is explicated in the table below.

Table 3.9: Details of Fields on Edit Native Call Screen

Field Name	Field Description
Name	Name of the Native Call activity
Description	Description of the Native Call activity
Default Extension	Extension of the file whether .bat, .exe or .sh
File Name (Absolute Path)	Name of the file with absolute path For example: ../../Solutions/Demo/EvalXform/EvalXform_OpenFile.bat
Arguments	Any arguments for selected batch or executable file
Working Directory	Directory, where you want the run the specified batch or executable file

5. Make the necessary changes.
6. Once you have made the required changes, click the **Save** button to save the changes. A screen is displayed confirming that the Native Call activity has been updated successfully. If the *comments* property is enabled, then clicking **Save** will display a screen where you need to enter comments related to updating the native call activity (refer to Figure 7.10).
7. Enter the comments in the *Add Comments* field.



The comment should be at least 1 character in length.

8. Click **OK** to save the comments. This displays a screen confirming that the native call activity has been updated successfully.

CREATING MAPPING ACTIVITY

Mapping is used to map data fields of source schema and target schema. In this Process Flow, different mapping functions (e.g. String, Math, Aggregation, Custom Method and Conditional Functions) are used.

Step to create the Mapping activity:

1. In the Adeptia Suite homepage menu, click **[+] Configure** to expand the tree. All the items in the **Configure** category are displayed.
2. Click **[+] Services** to expand the tree. All the items in the **Services** category are displayed.
3. Click **[+] Data Transform** to expand the tree, and then click **Data Mapping**. The Manage Data Mapping screen is displayed with the list of existing mapping activities (refer to Figure 7.15)
4. Click **New** link. The Create Mapping Activity screen is displayed (see Figure 3.21).

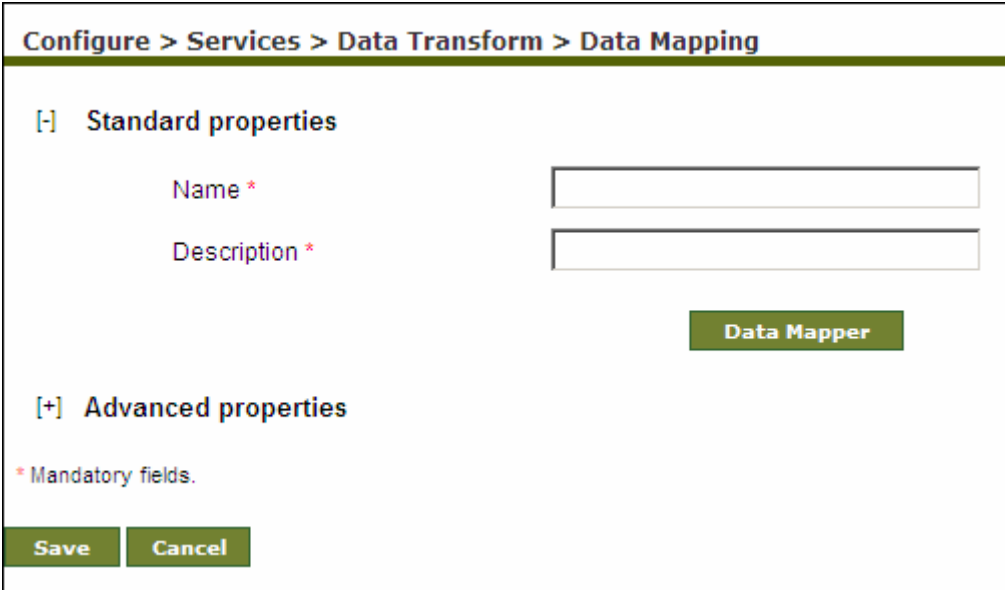

Figure 3.21: Create Data Mapping Activity

5. Enter the name and description of the new mapping activity in the *Name* and *Description* fields respectively.
6. Click **Data Mapper** button. This displays the Data Mapper applet (see Figure 3.22)

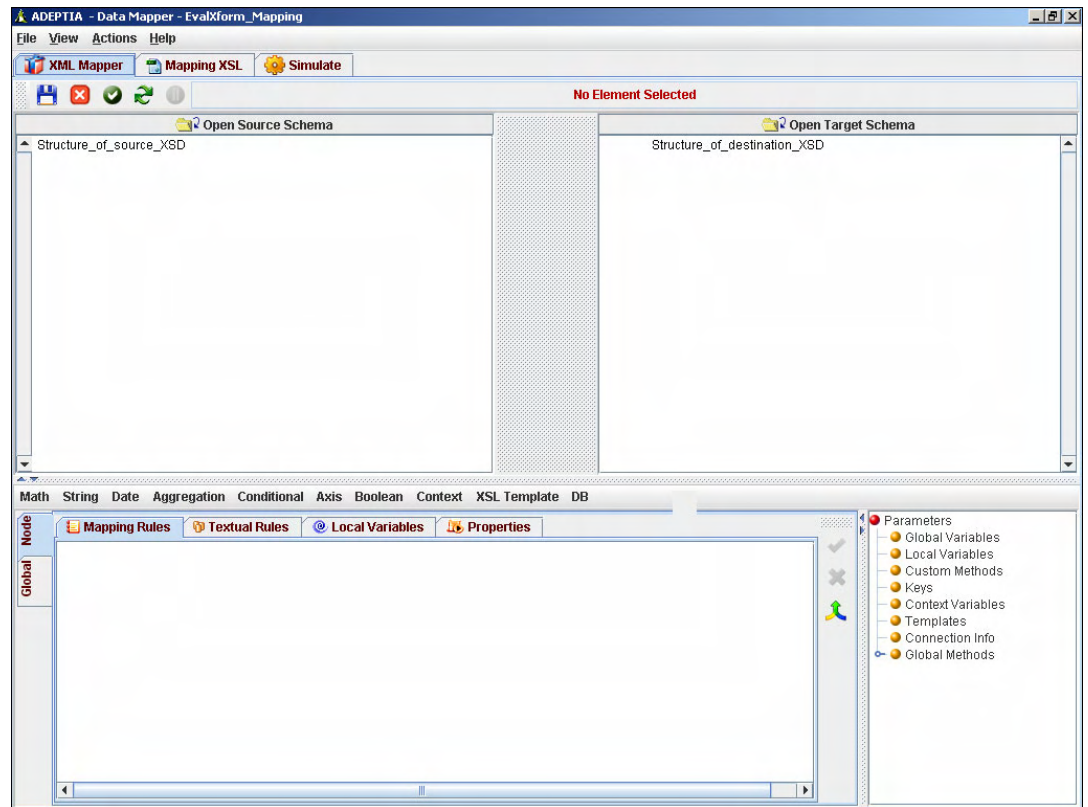

Figure 3.22: Data Mapper Applet

- Click **Open Source Schema** button to load the source schema. This displays the Select Schema screen (see Figure 3.23).

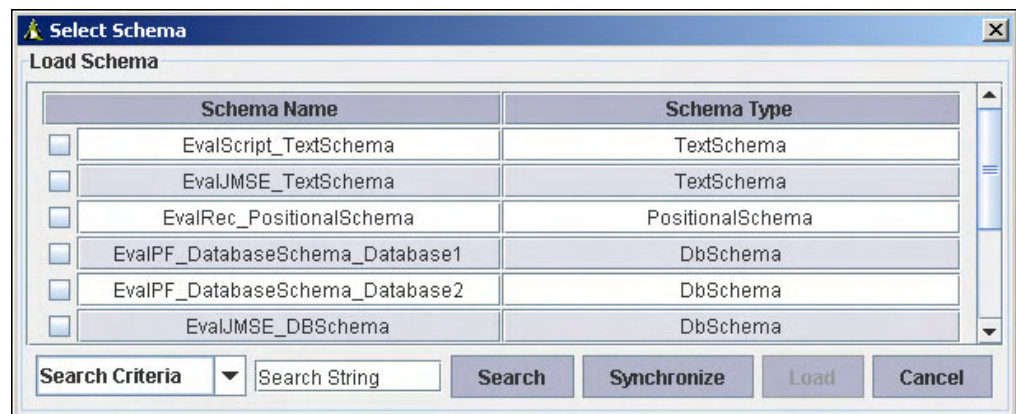

Figure 3.23: Select Schema

- Select the Source Schema (*EvalXform_DbSchema*) checkbox from the *Source Schema* list and click **Load** button. This loads the selected schema in the Source Panel of the Data Mapper applet.
- Similarly, load the Target Schema (*EvalXform_ExcelSchema*) in the Target Panel of the Data Mapper applet.

- Click (🔍) to expand the tree structure for Source Schema and the Target Schema and display their elements (see Figure 3.24).

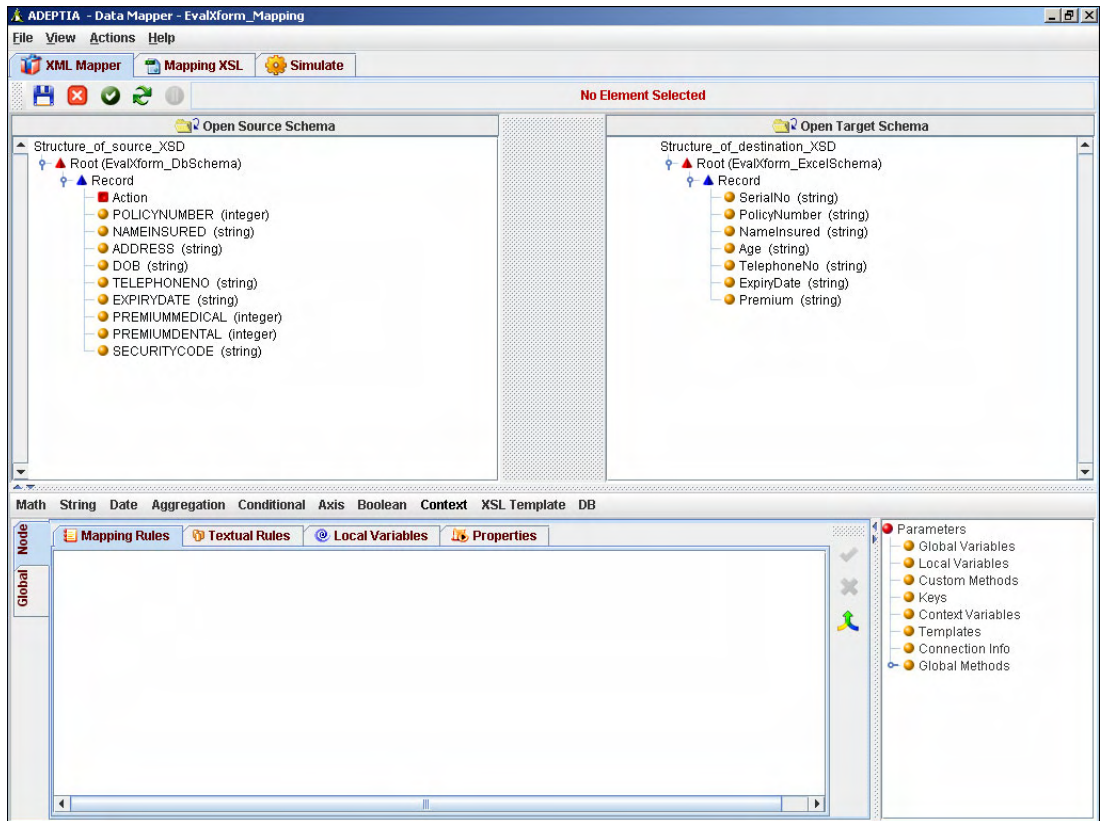

Figure 3.24: Source and Target Elements

- Select the **Record** element of the target schema and then click **Properties** tab in Mapping Graph Area.
- Click the *For Each* field and then double-click the **Record** element of the source schema. Click **Save Properties** to save the *For Each* property (see Figure 3.25).

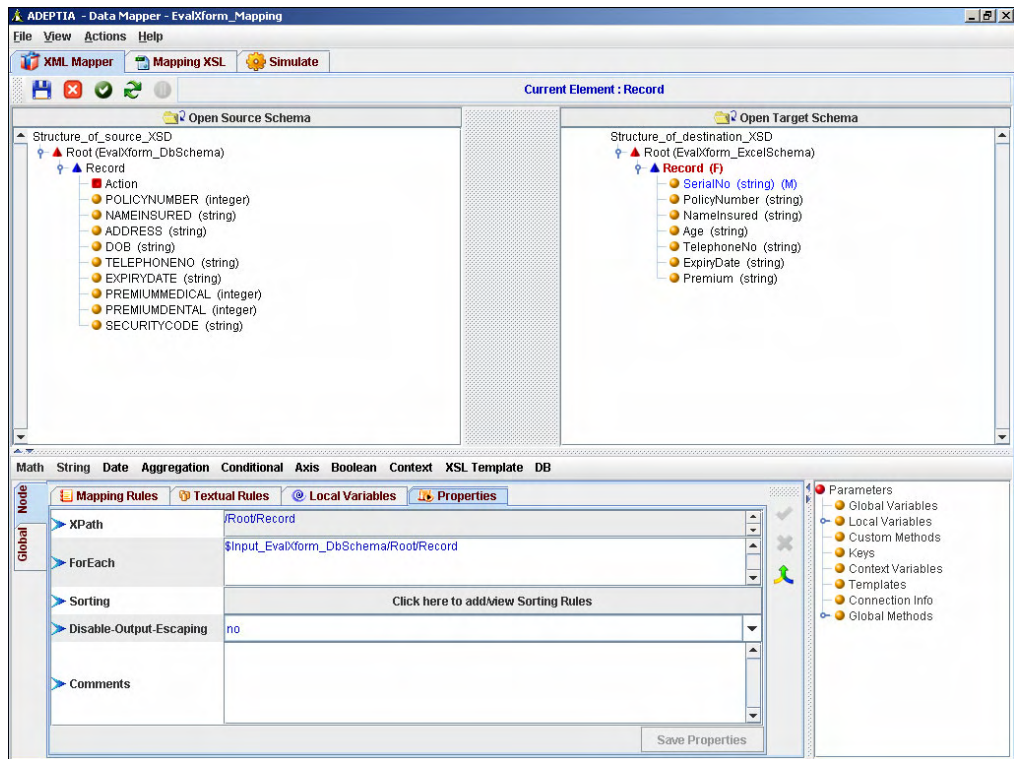

Figure 3.25: Apply *For Each* Property

- Click the node **SerialNo.** on the Target Panel. The node *SerialNo.* is displayed in the Mapping Graph Area (see Figure 3.26).

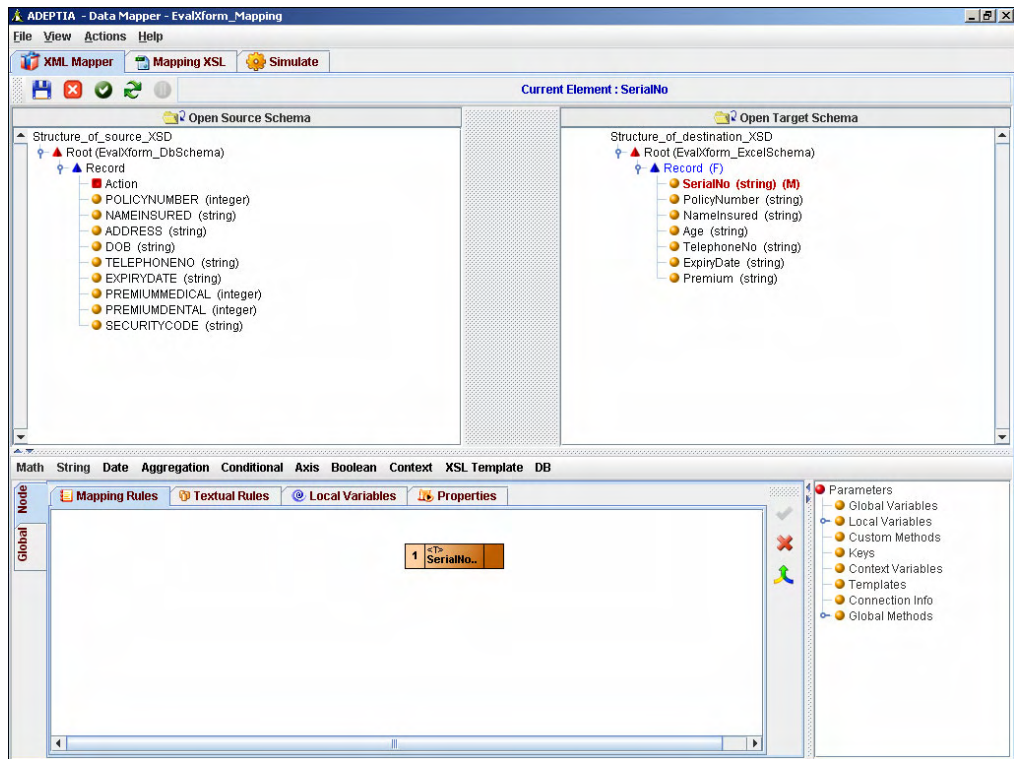

Figure 3.26: Select Target Node

14. Click the **Aggregation** mapping function and select the **Position** sub-function. A node for **Position** function is displayed in the Mapping Graph Area (see Figure 3.27).

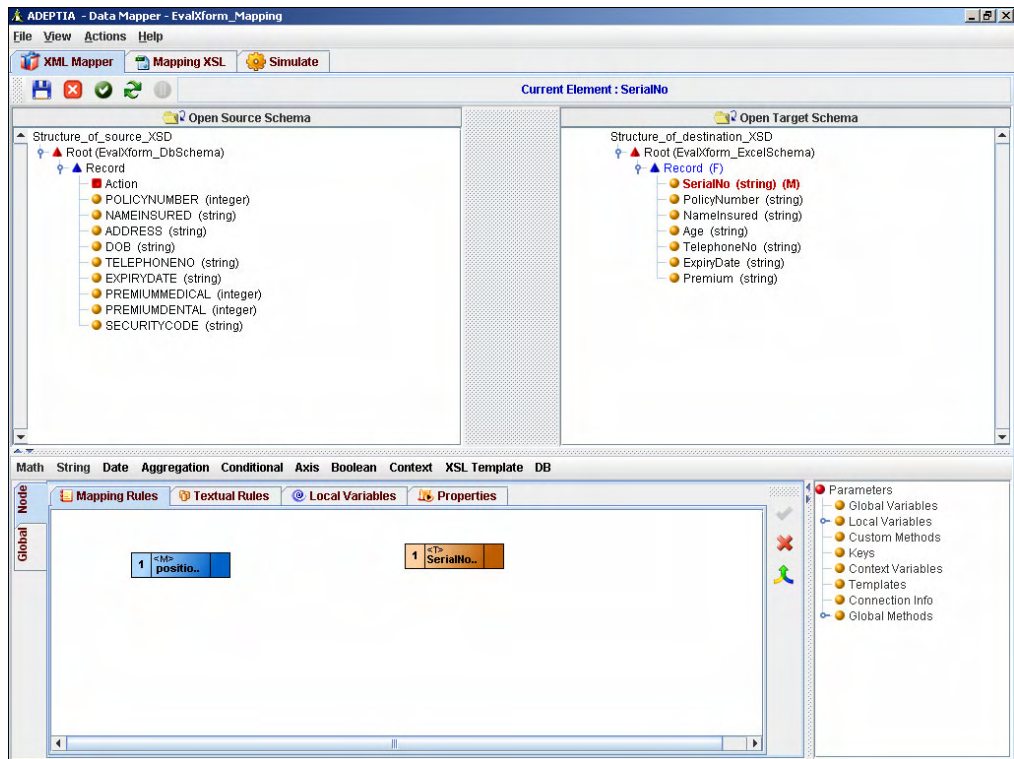

Figure 3.27: Select Position Function

15. Click the **Position** node in the Mapping Graph Area and drag the mouse pointer from the *Position* node to the *SerialNo* node. A line is displayed between *Position* node and *SerialNo* node (see Figure 3.28).

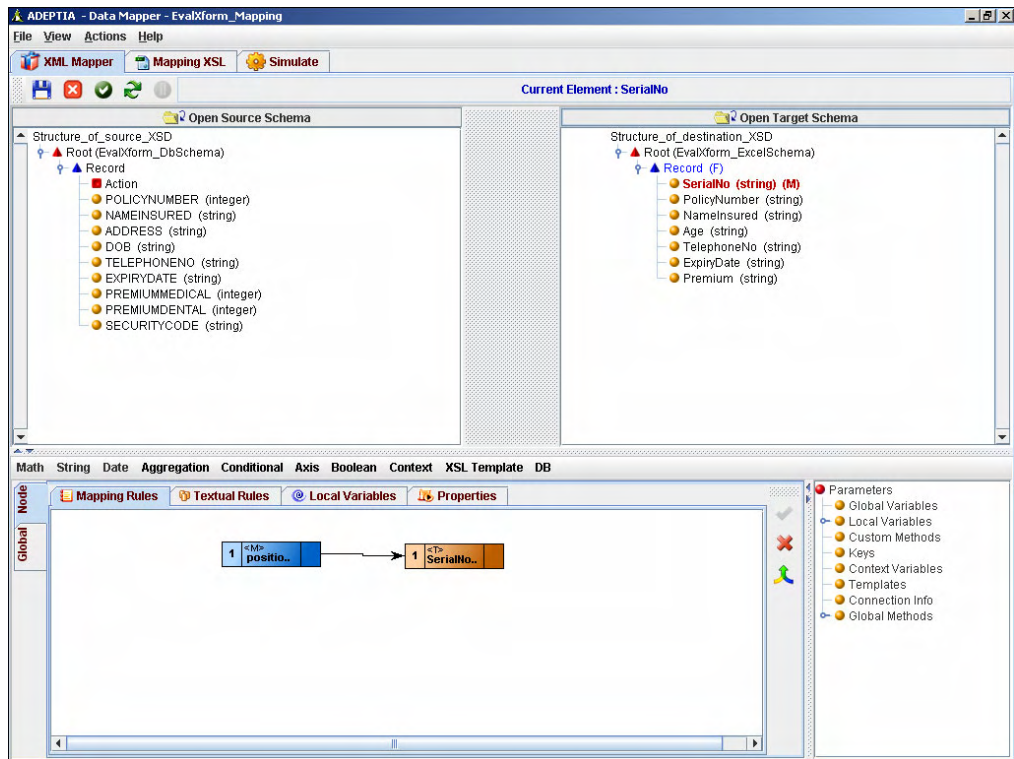



Figure 3.28: Map Position Function to Serial No.

16. Click the **Apply Mapping** () button to apply the mapping.
17. Click *PolicyNumber* in the Source Panel and drag the mouse pointer from the Source Panel to the *PolicyNumber* node in the Target Panel (see Figure 3.29).

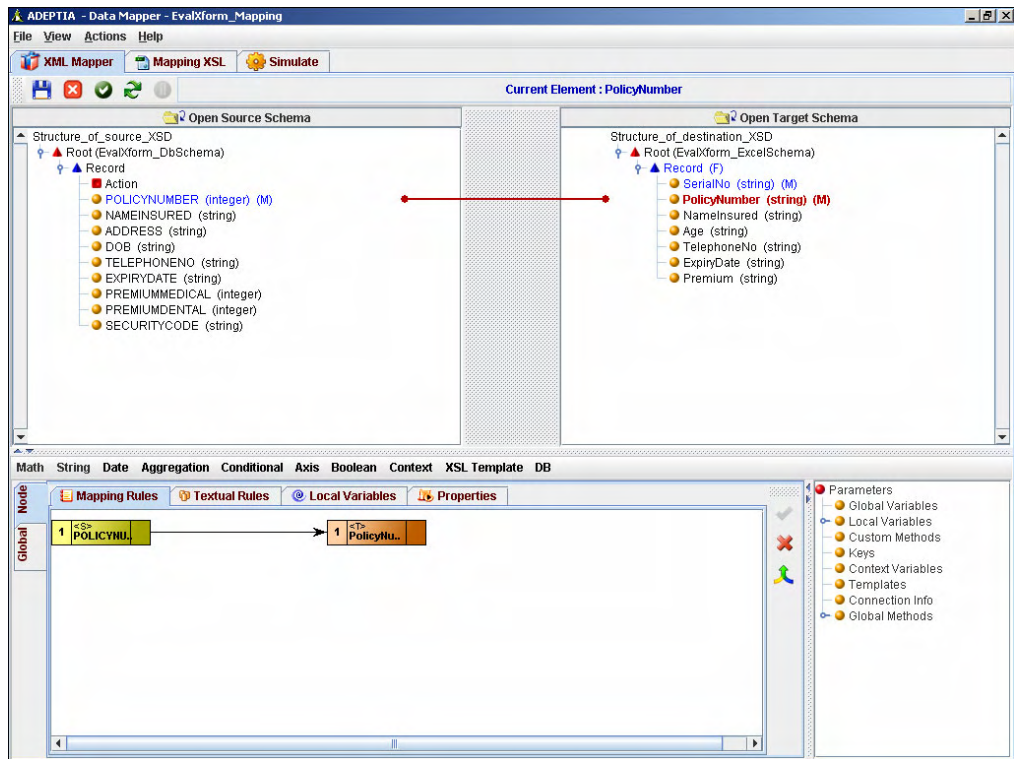



Figure 3.29: Map Policy Numbers

 The character **(M)** is suffixed next to the source and target elements to imply that they have been mapped.

18. To concatenate *NameInsured* and *Address* of the source schema, select the **NameInsured** node from the Target Panel. The selected node is shown in the Mapping Graph Area (see Figure 3.30).

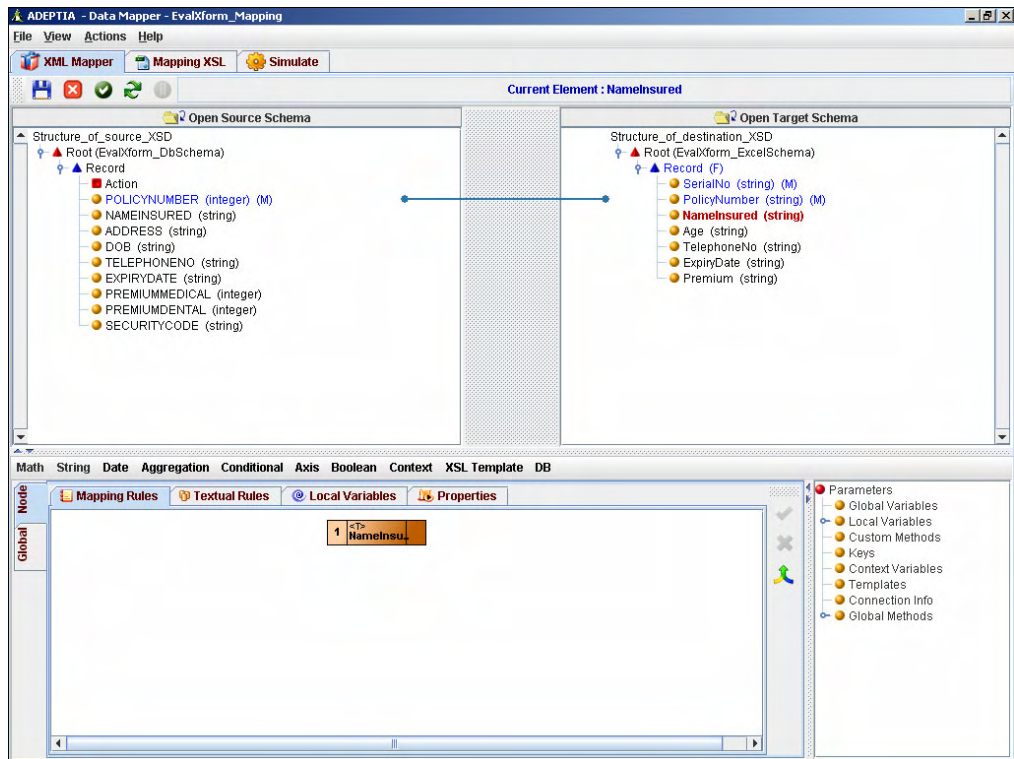

Figure 3.30: Select Name Insured

19. Double-click the **NameInsured** node in the Source Panel. The *NameInsured* node is shown in the Mapping Graph Area. Similarly, double-click the **Address** node in the Source Panel (see Figure 3.31).

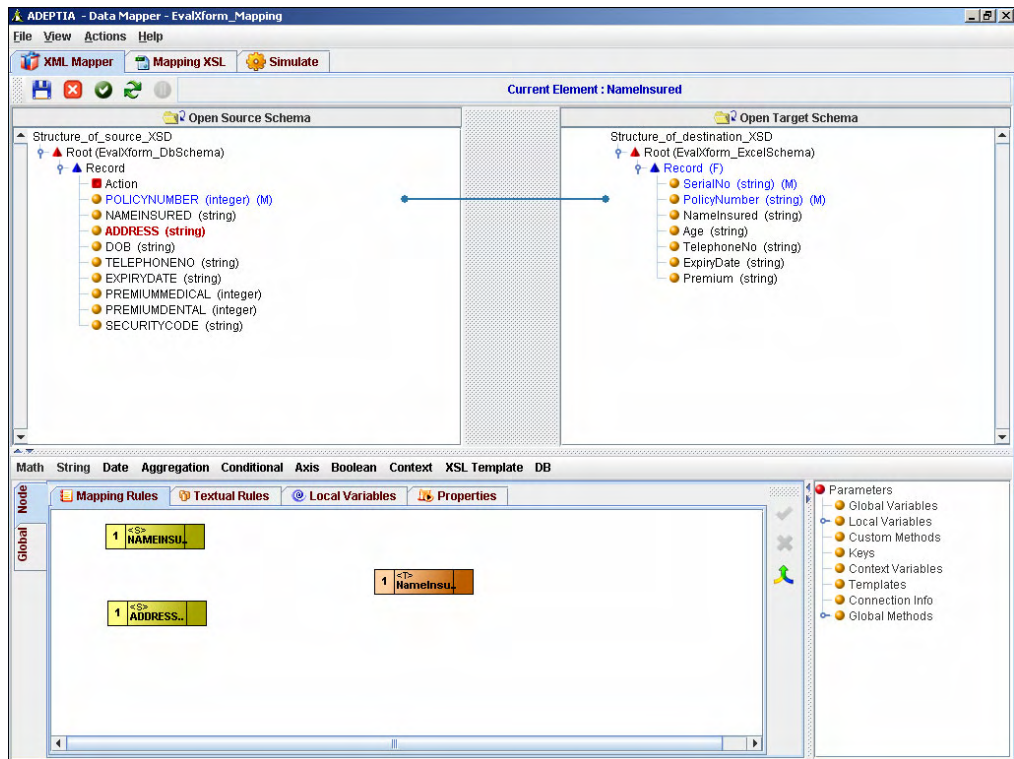

Figure 3.31: Select Source Nodes

20. Click the **String** mapping function and select **Concat** sub-function. The *Concat* node is shown in the Mapping Graph Area.
21. Create a link from the output of the *NameInsured* node to the first input of the *Concat* node.
22. Create a link from the output of the *Address* Node to the second input of the *Concat* node.
23. Create a link from the output of the *Concat* function node to input of the *NameInsured* node (see Figure 3.32).

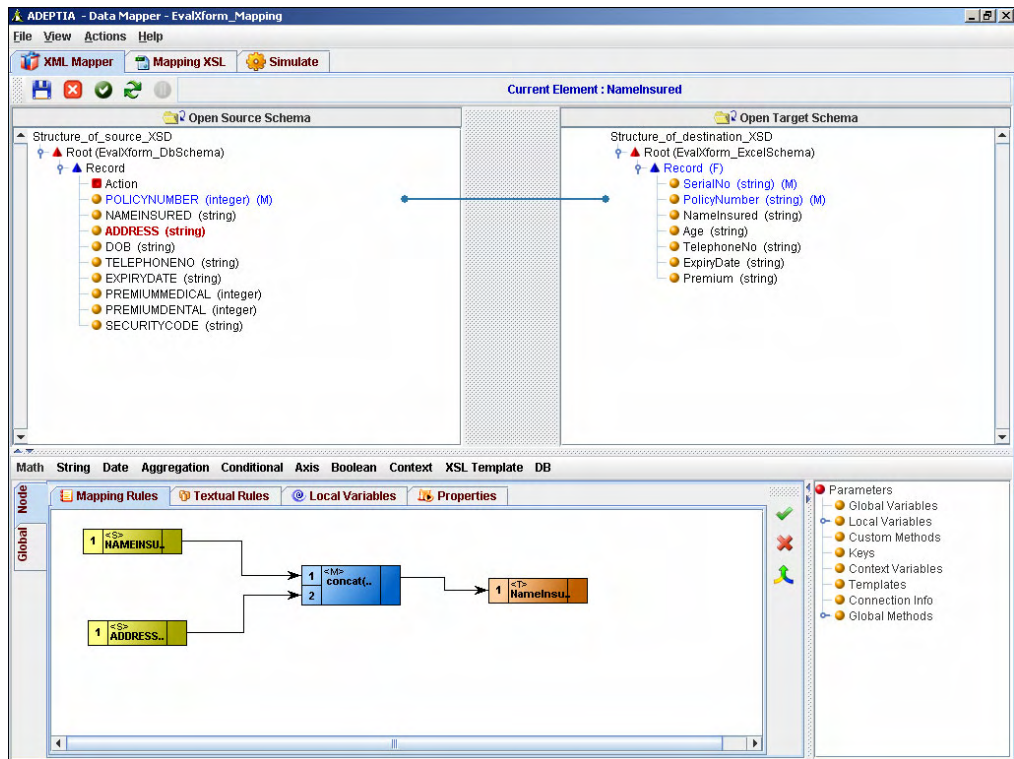

Figure 3.32: Create Links

- Click the **Apply Mapping** (✔) button to apply the mapping. Lines indicating mapping between the source and target nodes are displayed (see Figure 3.33).

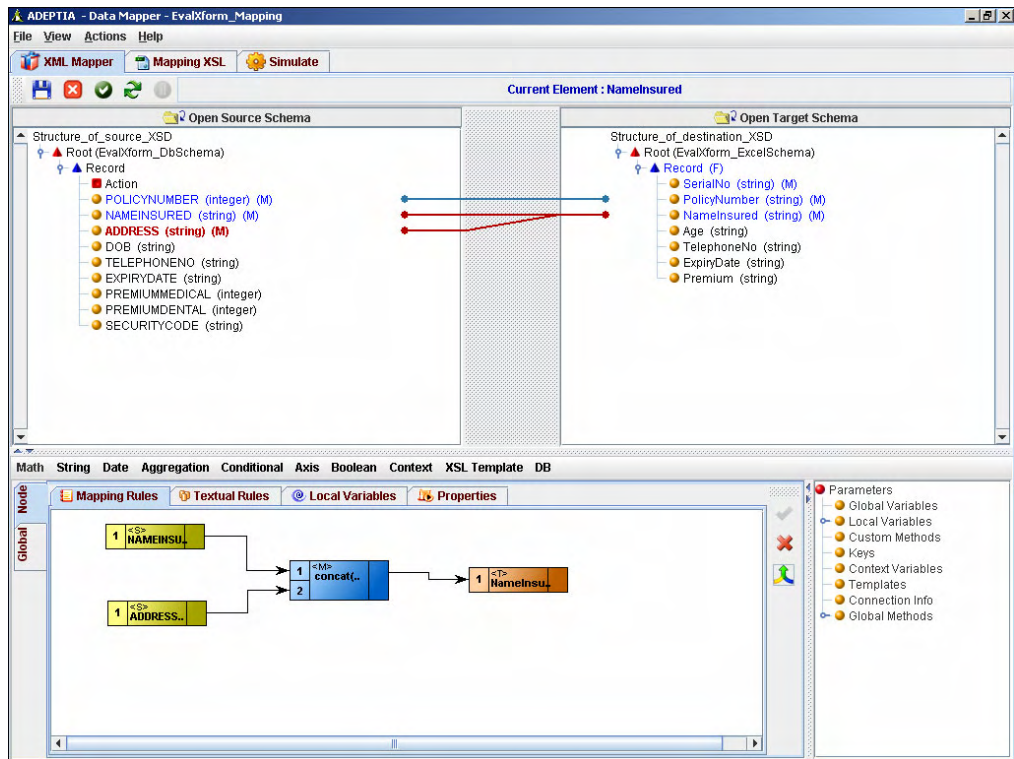

Figure 3.33: Apply Mapping

25. To calculate the Age based on the *DOB* (Date of Birth) field of the source schema, custom method is used. A custom method is used to call a Java method, which calculates the current age, based on *DOB*.
26. To define a Custom Method, click the **Global** tab in the Mapping Graph Area.
27. Click the **Custom Methods** tab. The Custom Methods Panel is displayed (see Figure 3.34).

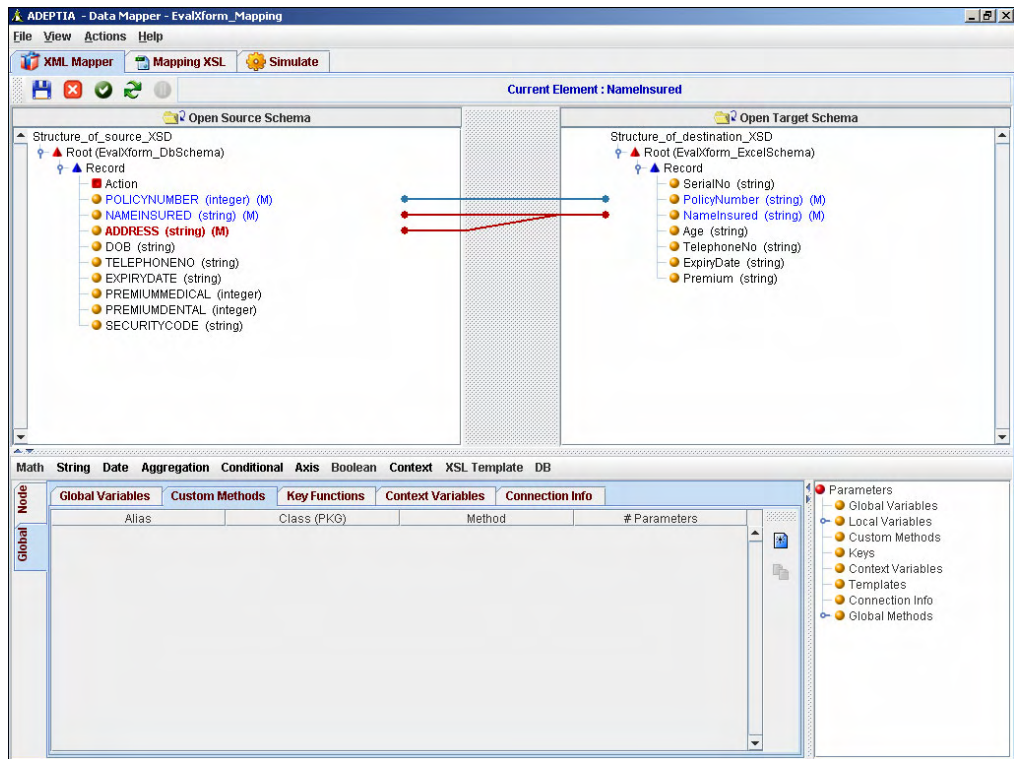



Figure 3.34: Custom Methods Pane

28. Click the **Add Method** () button to add a Custom Method. A row is inserted with following columns (see Figure 3.35):

- Alias
- Class (PKG)
- Method
- # Parameters

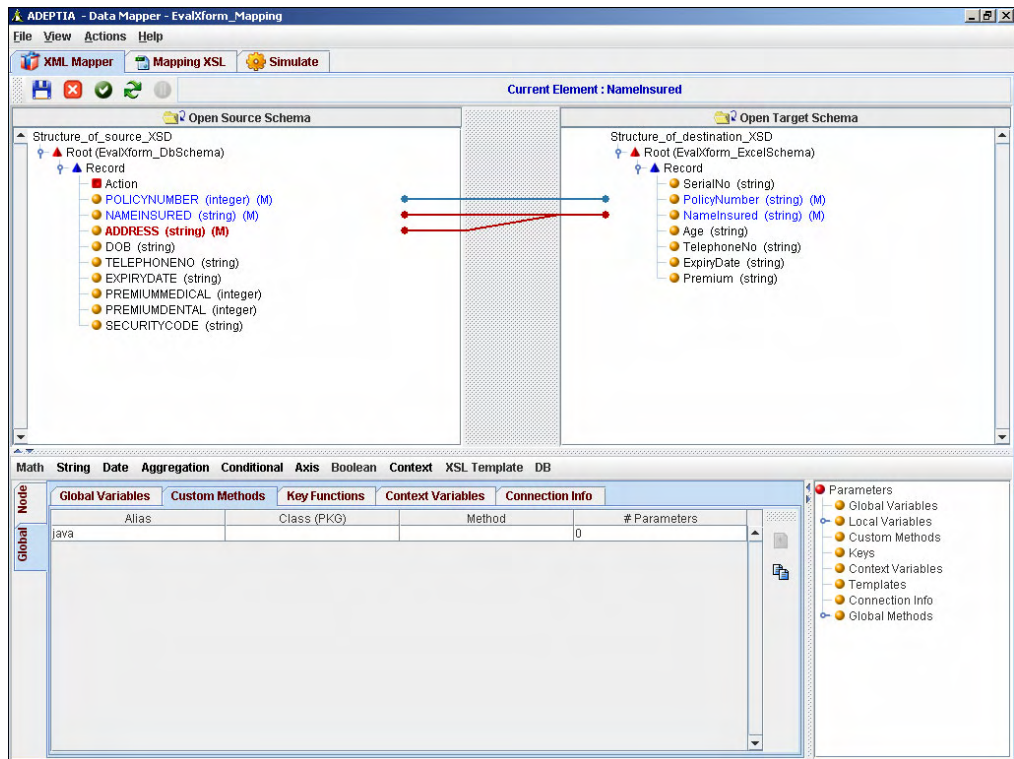



Figure 3.35: Add Custom Method

29. *Alias* column automatically gets populated with value 'java'.
30. Click the *Alias* field, press **[Tab]** or **[Enter]** key to go to the *Class (PKG)* field
31. Enter the fully qualified name of the Java class (*CustomMethodCall*) in the *Class (PKG)* field.
32. Press **[Tab]** or **[Enter]** key to go to the *Method* field and enter the name of the method (*getAge*) in the *Method* column.

 The Java Method specified here is stored in `../serverkernel/CustomClasses` folder.

33. Press **[Tab]** or **[Enter]** key to go to the *#Parameters* field and enter the number of arguments (*1*) taken by Method in the *# Parameter* column.
34. Press **[Tab]** or **[Enter]** key to return to the *Alias* field. This will save the added Custom Method (see Figure 3.36).

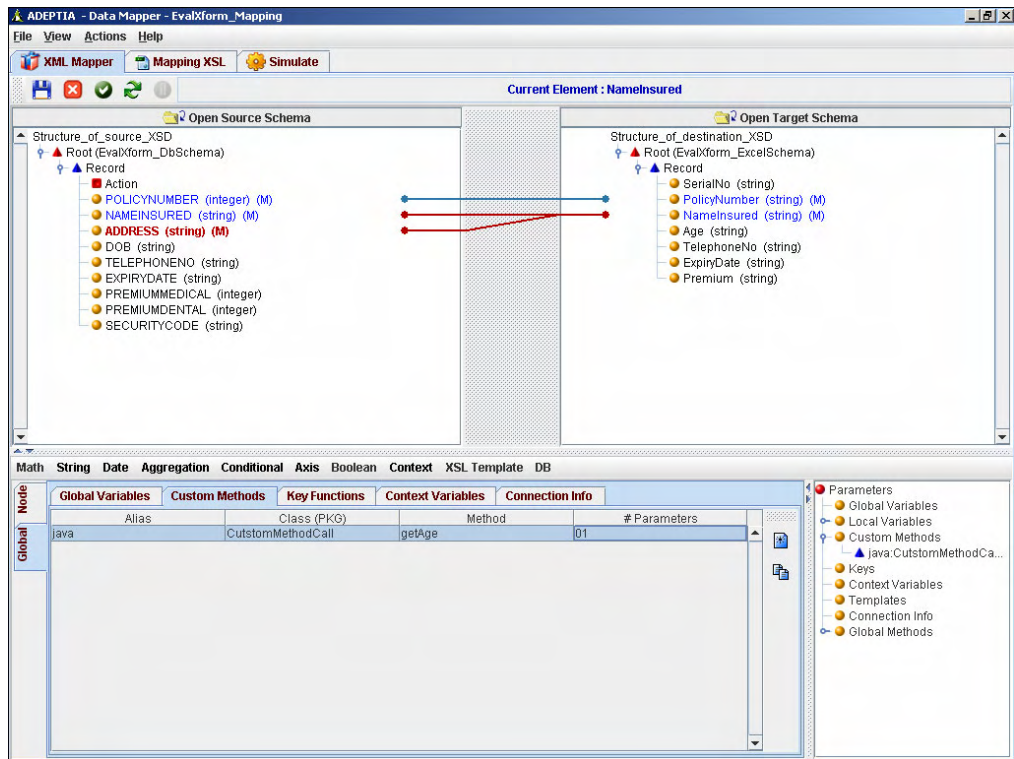



Figure 3.36: Save Custom Method

 The saved custom method is displayed under *Custom Methods* in the Parameters Panel.

35. Click the **Node** tab to map the declared Custom Method to the *Age* node. The Mapping Graph Area is displayed.
36. Click the node **Age** in the Target Panel. The *Age* node is displayed in the Mapping Graph Area.
37. Double-click the **DOB** node in the Source Panel. The *DOB* node is displayed in the Mapping Graph Area.
38. Expand the *Custom Methods* tree in the Parameters Panel. Double-click the defined Custom Method. The selected Custom Method node is displayed in the Mapping Graph Area (see Figure 3.37).

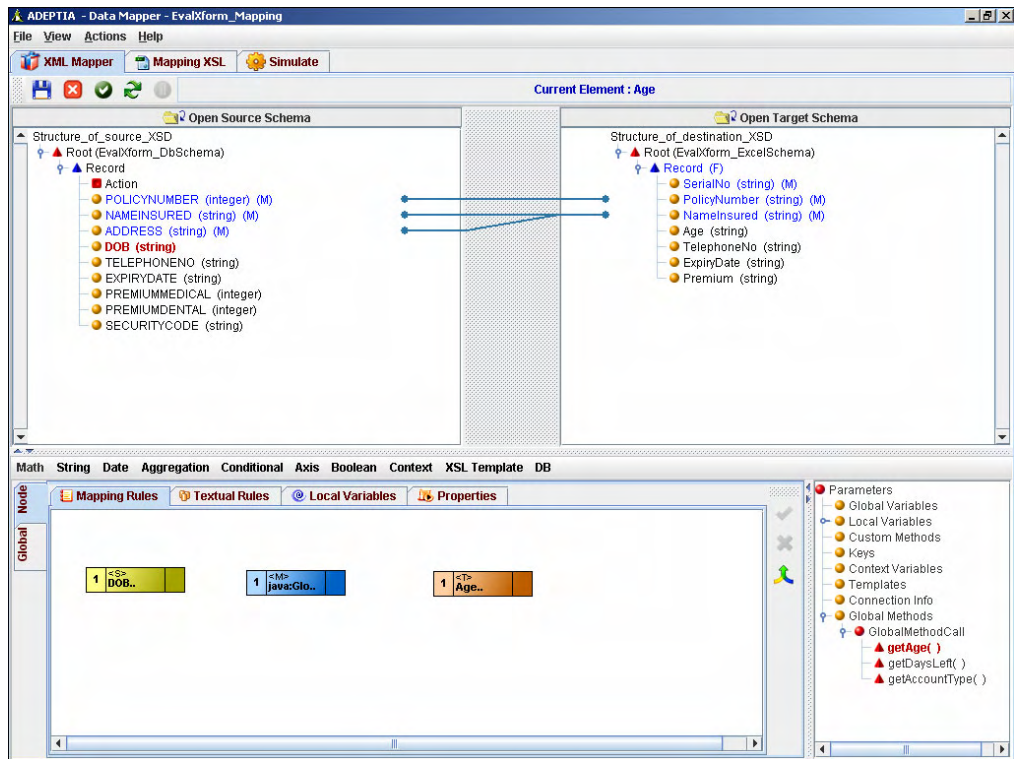



Figure 3.37: Select Custom Method

39. Create a link from the output of the *DOB* node to the input of the *Custom Method* node.
40. Create a link from the *Custom Method* node to the input of the *Age* node.
41. Click the **Apply Mapping**  button to apply the mapping. Lines indicating mapping between the source and target nodes are displayed (see Figure 3.38).

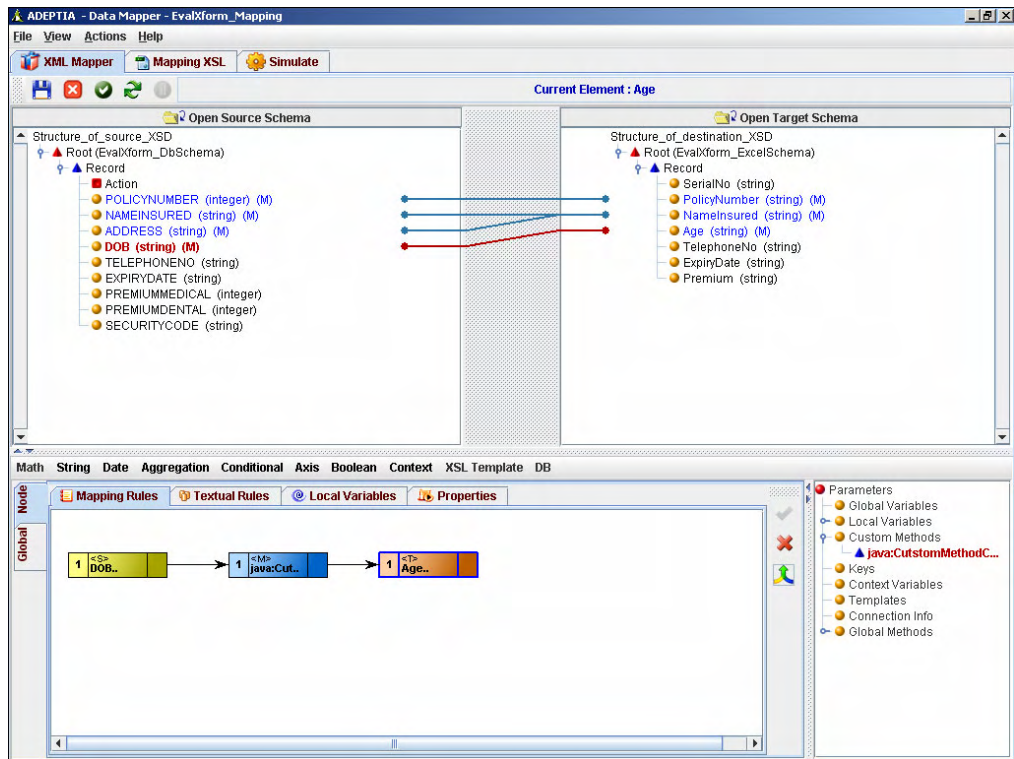

Figure 3.38: Map Custom Method

42. Click the **TelephoneNo** node in the Source Panel and drag the mouse pointer from the Source Panel to the **TelephoneNo** node in the Target Panel.
43. Similarly, map **ExpiryDate** node of the Source Panel with the **ExpiryDate** node of the Target Panel.
44. To add the values of *PremiumMedical* and *PremiumDental*, the **Add** function is used.
45. To use the **Add** function, click **Premium** node in the Target Panel. The *Premium* node is displayed in the Mapping Graph Area.
46. Double-click the **PremiumMedical** node in the Source Panel. The *PremiumMedical* node is displayed in the Mapping Graph Area. Similarly, double-click the **PremiumDental** node in the Source Panel (see Figure 3.39).

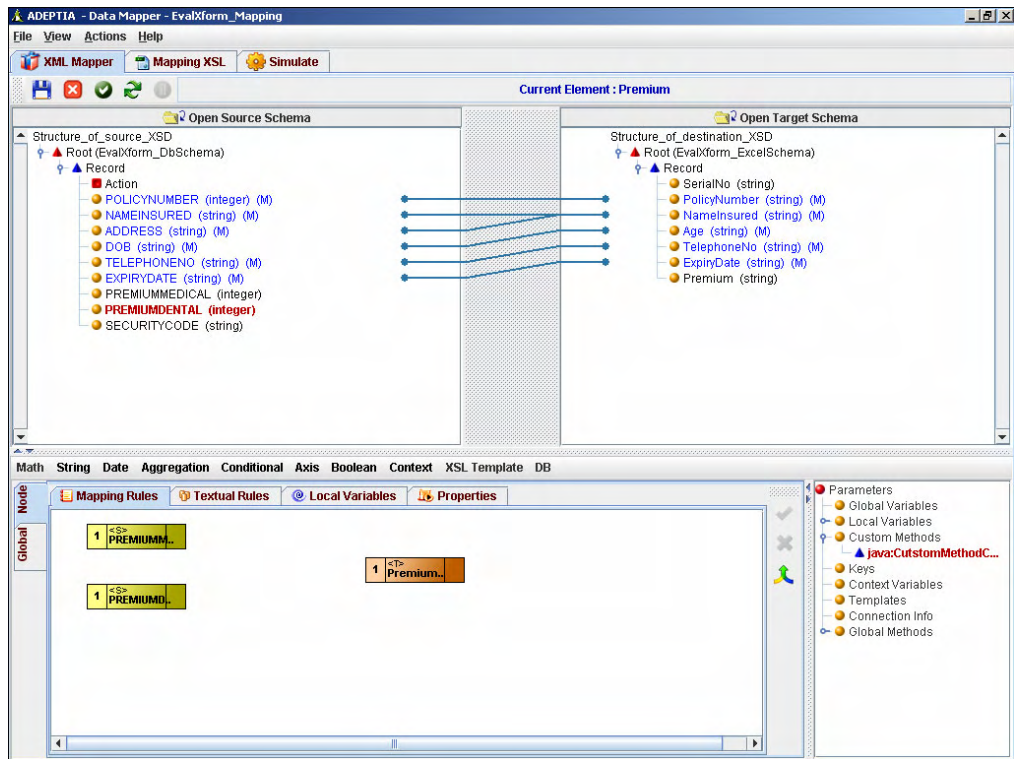



Figure 3.39: Select Source Nodes

47. Click the **Math** mapping function and select **Add** sub-function. The *Add* function node is shown in the Mapping Graph Area.
48. Create a link from the output of the *PremiumMedical* node to the first input of the *Add* function node.
49. Create a link from the output of the *PremiumDental* node to the second input of the *Add* function node.
50. Create a link from the output of the *Add* function node to the input of the *Premium* node.
51. Click the **Apply Mapping**  button to apply the mapping. Lines indicating mapping between the source and target nodes are displayed (see Figure 3.40).

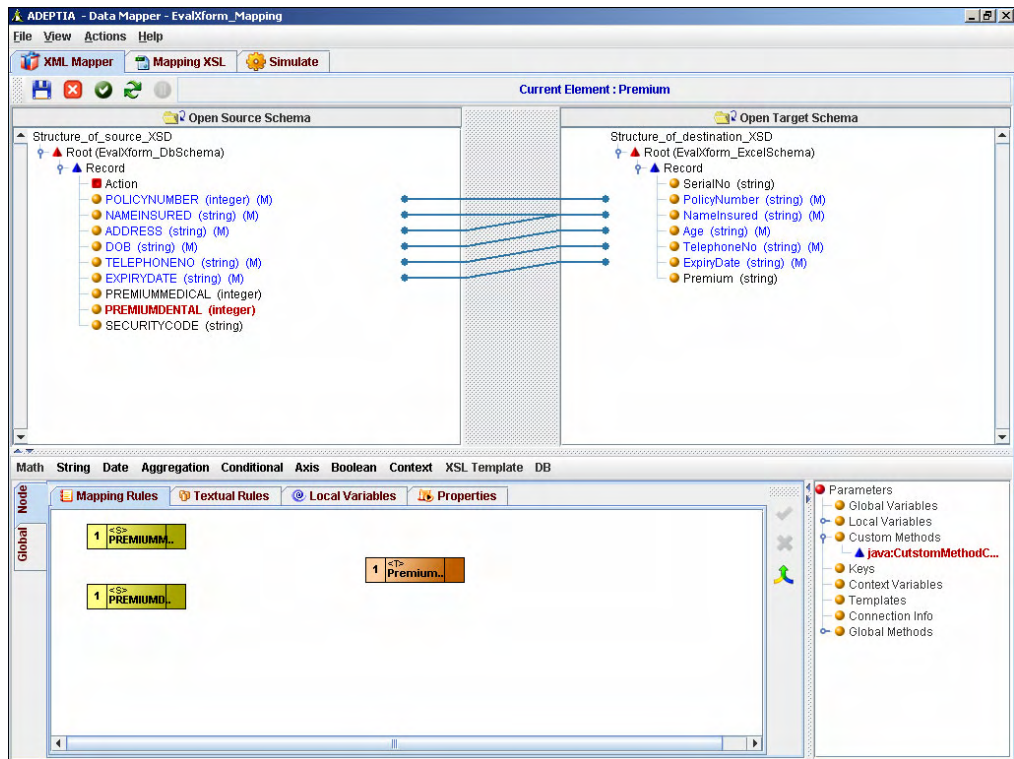

Figure 3.40: Map Premium Nodes

52. To filter the record based on the value of *PremiumMedical* field of source schema, **IFF Condition** is used. In this Process Flow, records in which the value of the *PremiumMedical* is less than US\$ 30 are filtered and not passed to the target file.
53. To use **IFF condition**, click the **Record** Node in the Target Panel. The *Record* node is displayed in the Mapping Graph Area.
54. Double-click the **PremiumMedical** node in the Source Panel. The *PremiumMedical* node is displayed in the Mapping Graph Area.
55. To add the constant value (30), right-click the blank space in the Mapping Graph Area and select the **Constant** option. A *Constant* node is displayed in the Mapping Graph area.
56. Double-click the *Constant* node. The Input dialog box is displayed (see Figure 3.41).



Figure 3.41: Input Dialog Box

57. Enter the required constant value (30) in the *Enter the Value* field and click the **OK** button. The entered value is displayed in the *Constant* node (see Figure 3.42).

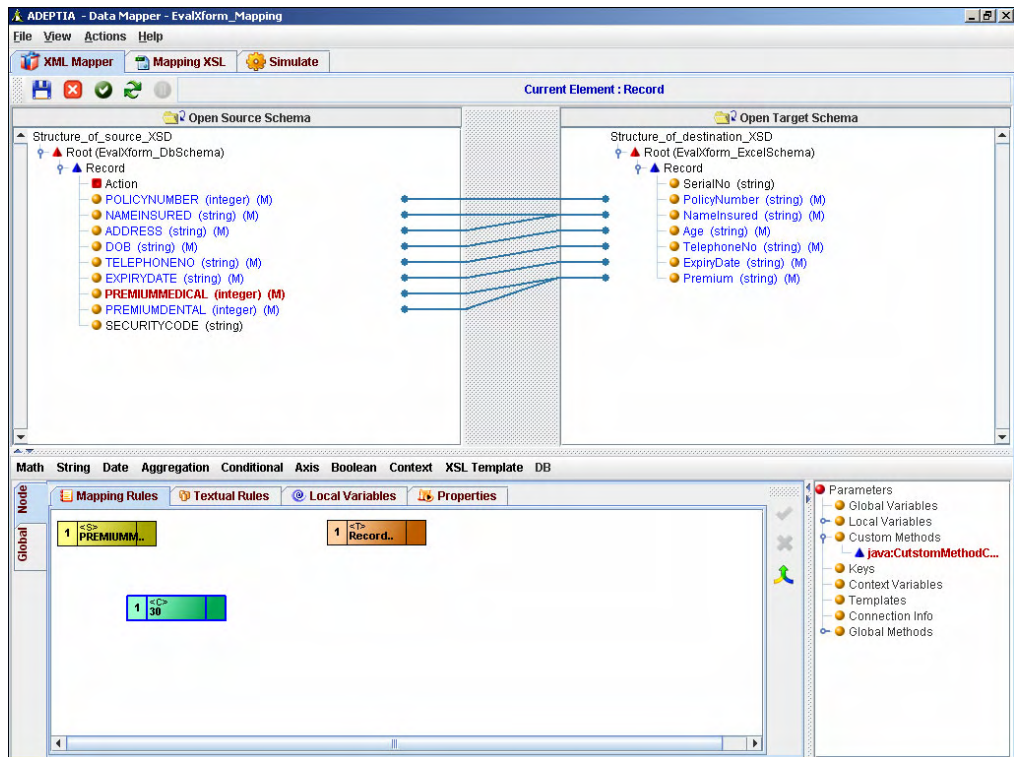

Figure 3.42: Constant Value Entered

58. Click the **Boolean** mapping function and select **Greater Than (>)** sub-function. The *Greater Than* function node is displayed in the Mapping Graph Area.
59. Create a link from the output of the *PremiumMedical* node to the first input of the *Greater Than* node.
60. Create another link from the *Constant* node to the second input of the *Greater Than* node (see Figure 3.43).

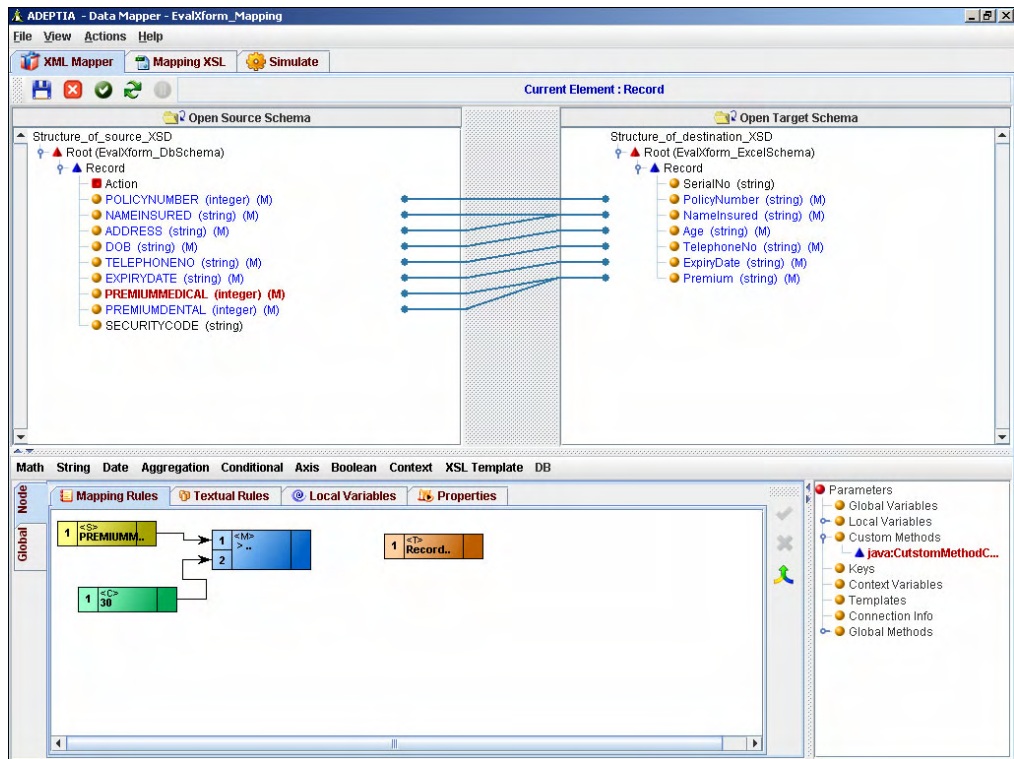



Figure 3.43: Create Links

61. Create another *Constant* node with the value ('OK').

	<p>While adding the value OK, check the <i>Add Quote</i> checkbox in <i>Constant Value</i> dialog box.</p>
---	---

62. Click the **Conditional** mapping function and select **IF CONDITION > For Filtering Records** sub-function. The *IFF Condition* node is displayed in the Mapping Graph Area (see Figure 3.44).

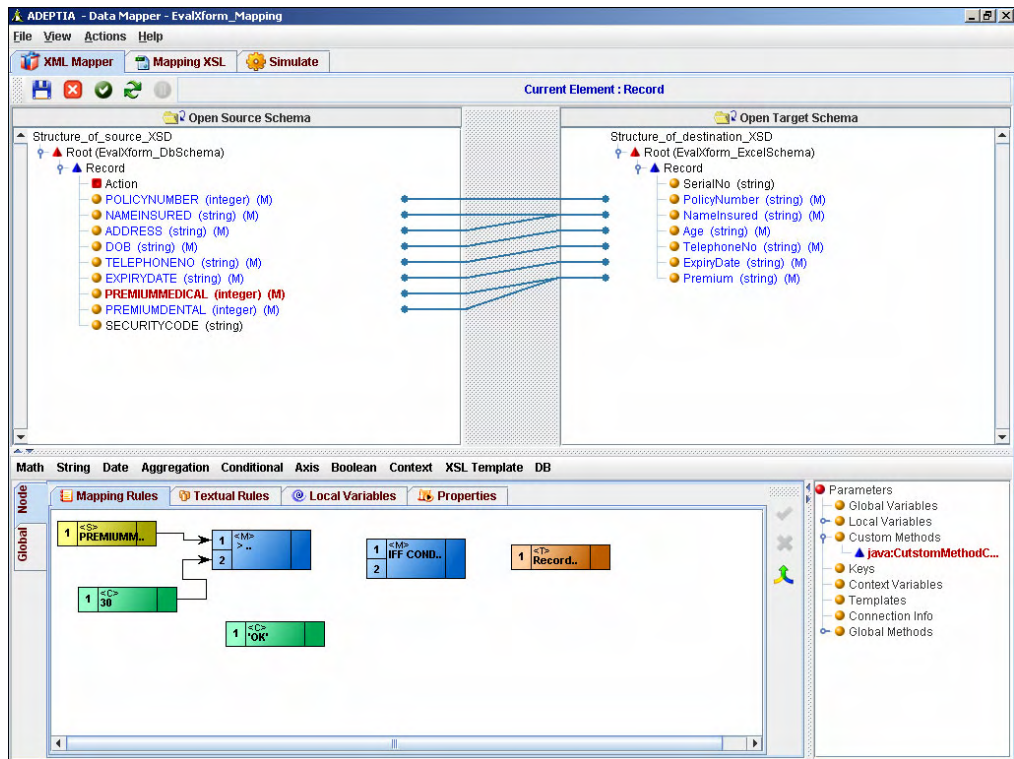

Figure 3.44: Select IFF Condition

63. Create a link from the output of the *Greater Than* function node to the first input of the *IFF Condition* node.
64. Create a link from the output of the *Constant* node ('OK') to the second input of the *IFF Condition* node.
65. Create a link from the output of the *IFF Condition* node to the input of the *Record* node.
66. Click the **Apply Mapping** (✔) button to apply the mapping. Lines indicating mapping between the source and target nodes are displayed (see Figure 3.45).

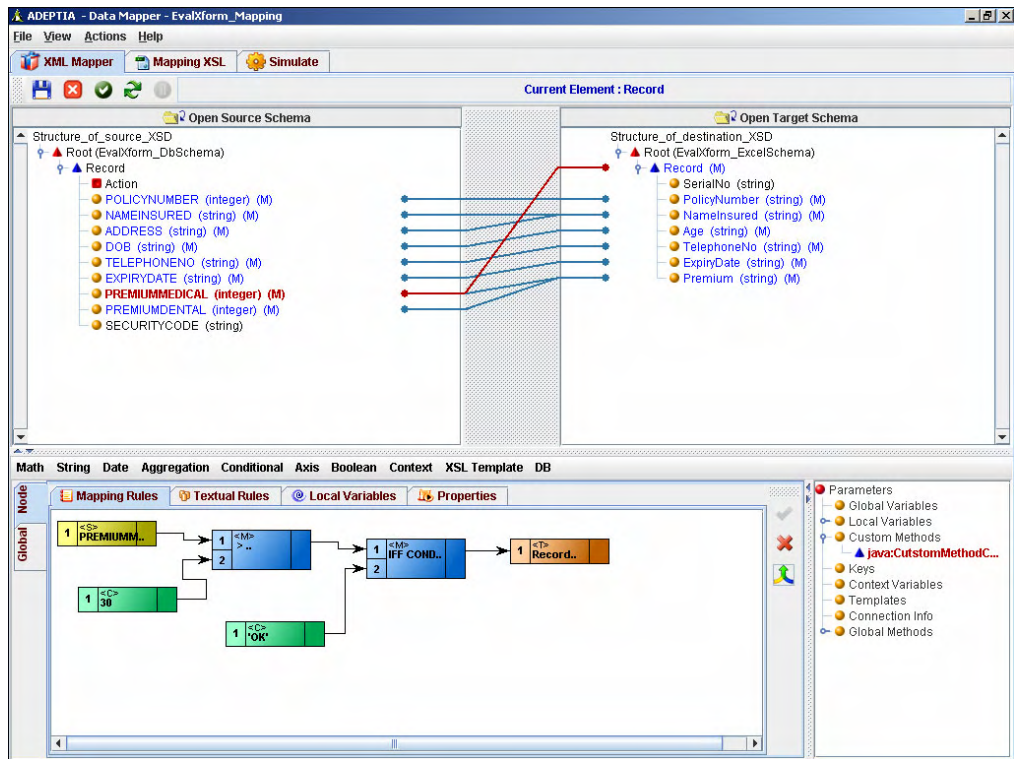



Figure 3.45: Map IFF Condition with Target Element

67. Save the mapping by clicking the **File** menu and selecting **Save**. A dialog box is displayed confirming that the mapping activity has been saved successfully.

	Alternately, you can save the mapping activity by clicking Save () button on the Tool Bar.
---	--

68. If the *comments* property is enabled, then clicking **Save** will display a screen where you need to enter comments related to the mapping (refer to Figure 7.18).
69. Enter the comments in the *Specify comments for mapping object (object name)* field.

	The comment should be at least 1 character in length.
---	---



70. Click **OK** to save the comments. This displays a dialog box confirming that the mapping has been saved successfully.
71. Exit the Data Mapper applet by clicking **File** menu and selecting **Exit**.

CREATING PROCESS FLOW (EvalXform_ProcessFlow)

A Process Flow is the set of activities arranged in a sequence to perform a specific task(s). It is created by combining various activities such as Source, Target, Schema or Transformer activities in a logical sequence. Process Designer is used to create a Process Flow. Process Designer has list of activities created. You only need to arrange them in a logical sequence and connect them with **BPMN** Flows.

Steps to create Data Transformation Process Flow:

1. In the Adeptia Suite homepage menu, click **[+] Design** to expand the tree. All the items in the **Design** category are displayed.
2. Click **[+] Process Flow** to expand the tree and then click **Process Flow**. The Manage Process Flow screen is displayed with the list of existing Process Flows (refer to Figure 7.27).
3. Click the **New** link. The Create Process Flow screen is displayed (refer to Figure 7.28).
4. Enter the name and the description of the new Process Flow in the *Name* and *Description* fields respectively.
5. Select the logging level from the *Logging Level* drop-down list. There are four levels of logging. These are described in Table 7.9.
6. Select repository file retention from the *Repository File Retention* option. During execution Process Flow creates a temporary repository file to store the intermediate data. These repository files can cause unnecessary disk space usage and you may want to delete them after execution of the Process Flow. On the other hand sometime these repository files can be helpful in case of failure of Process Flow execution. For each instance of the Process Flow execution a unique repository folder is created that contains Source, intermediate XML data files and target formatted data. By default repository files are being stored in the repository folder of Adeptia Suite. You can also choose an option to delete them or to archive them in a different location. There are four options for the Repository File Retention. These are described in Table 7.10.
7. Click the **Process Designer** button to open Process Designer. The Process Designer Screen is displayed (refer to Figure 7.29).
8. Once the Process Designer screen is displayed, a message to synchronize the list of activities and Process Flow with the Adeptia Suite is displayed. Click **OK** to synchronize.

	<p>Alternately, you can synchronize the list of activities and Process Flow with the Adeptia Suite by clicking the Synchronize () button displayed on the Tool Bar.</p>
---	---

9. Click **[+] Activities** in Activities Panel, to expand the list of services and then click **[+] Source**. All the items in the **Source** category are displayed.
10. Click **[+] Database Source**. A list of existing Database Source activities is displayed.
11. Select **EvalXform_DBSource** and drag it to the Graph Canvas Area (see Figure 3.46).

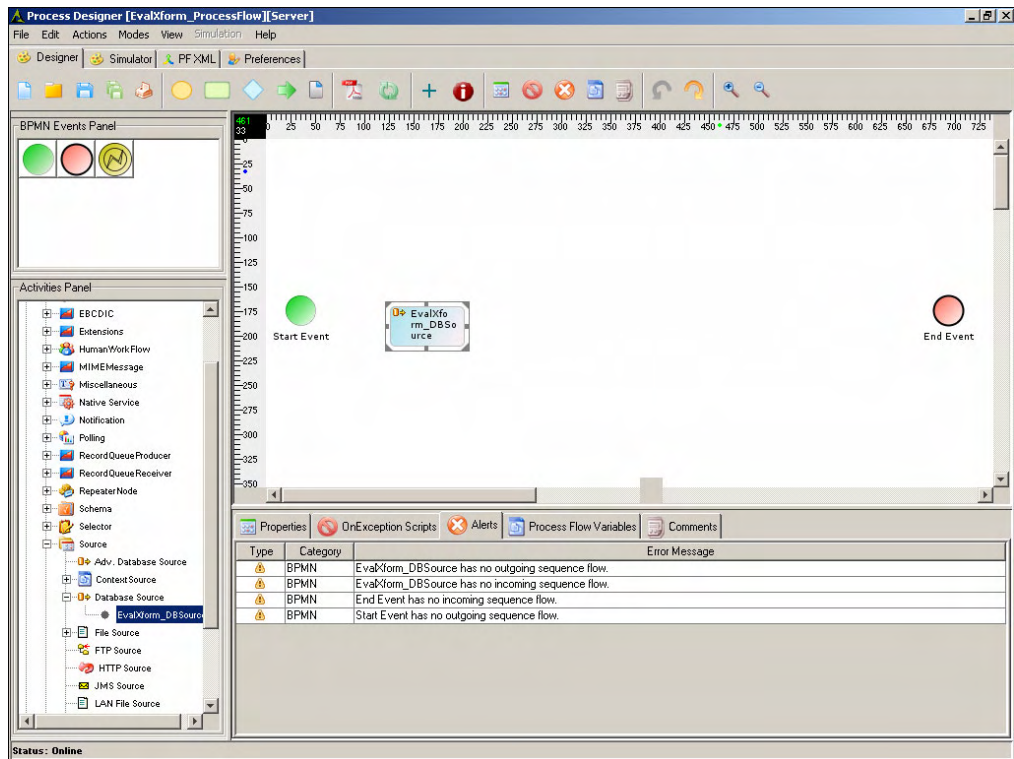

Figure 3.46: Drag Database Source to Graph Canvas Area

12. Similarly, click **[+] DataTransform** and then **[+] Data Transform**. Select **EvalXform_Mapping** activity and drag it to the Graph Canvas Area.
13. Click **[+] Schema** and then **[+] Excel Schema**. Select **EvalXform_ExcelSchema** activity and drag it to the Graph Canvas Area.
14. In Graph Canvas Area, right-click **EvalXform_ExcelSchema** and select **View Properties**. Properties of **EvalXform_ExcelSchema** are shown in the bottom pane (see Figure 3.47).

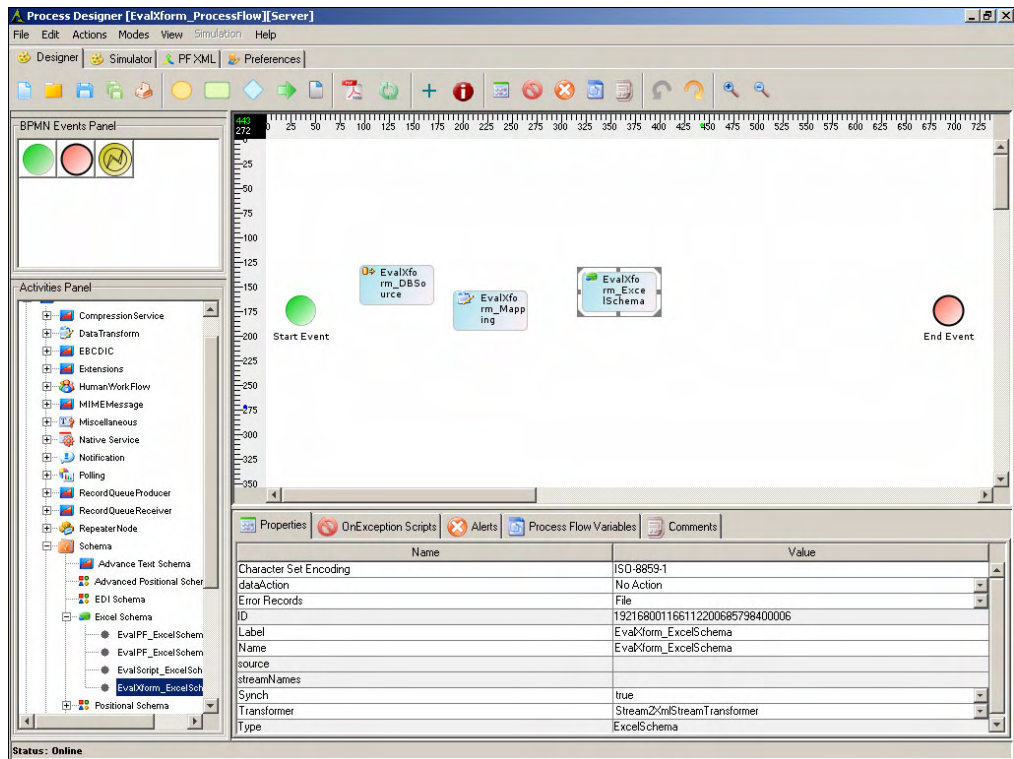

Figure 3.47: View Properties of *EvalXformExcelSchema* Activity

15. The value of Transformer property is set to ***Stream2xmlStreamTransformer***. Click the value box and change it to ***XmlStream2StreamTransformer***. When schema is used at target end, its transformer type must be ***XmlStream2StreamTransformer***.
16. Click **[+] Target** and then **[+] File Target**. Select **EvalXform_FileTarget** activity and drag it to the Graph Canvas Area.
17. Click **[+] Native Service** and then **[+] Native Call**. Select **EvalXform_NativeCall** activity and drag it to the Graph Canvas Area.
18. Once all the activities are dragged to the Graph Canvas Area, they must be connected using appropriate BPMN Flows or Control Flows.
19. Click the **Sequence Flow** (→) icon. The Sequence flow is selected.
20. To connect *Start Event* with *EvalXform_DBSource*, drag mouse pointer from *Start Event* to *EvalXform_DBSource* (see Figure 3.48).

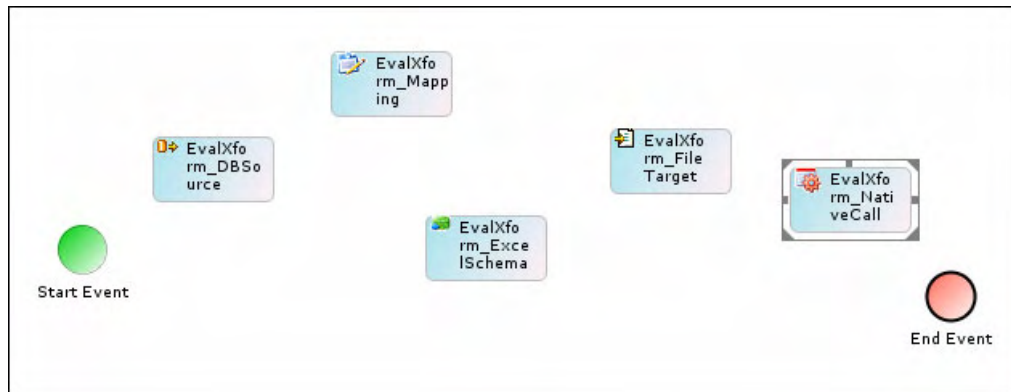

Figure 3.48: Connect Start Event to Database Source

21. Similarly, connect all other activities as shown in Figure 3.49

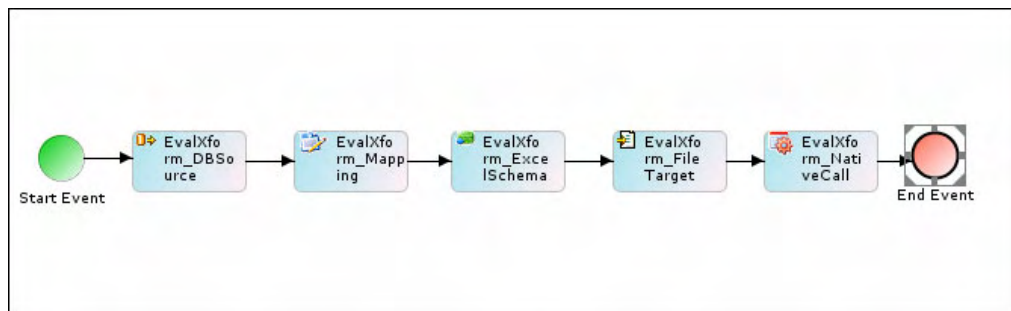



Figure 3.49: Connect all Activities

22. Save the Process Flow by clicking the **File** menu and selecting **Save Process Flow to Server**. A dialog box is displayed confirming that the *EvalXform_ProcessFlow* has been saved successfully. If the *comments* property is enabled, then clicking **Save Process Flow to Server** will display a screen where you need to enter comments related to creating the process flow (refer to Figure 7.37).
23. Enter the comments in the *Specify Comments for process flow customer* field.

	The comment should be at least 1 character in length.
---	---

24. Click **OK** to save the comments. This displays a screen confirming that the process flow has been created successfully.
25. Exit the Process Designer by clicking the **File** menu and selecting **Exit**.

4 SCRIPTED SERVICE PROCESS FLOW

This section describes the Scripted Service Process Flow.

In the Adeptia Suite this process flow is available in:

BPM Suite	Workflow Suite	Integration Suite	ETL Suite
√		√	√

INTRODUCTION

This sample Process Flow demonstrates the use of Scripted Service and generation of Dynamic File Name. Scripted Service is used to call Java code to perform the specific task. In this Process Flow a ZIP file, which contains two different text files, is used as source. Scripted Service calls a Java code, which extracts both the file and concatenates them into single text file. This file is further converted into Excel file and then compressed into a ZIP file. Current date is appended with the name of the ZIP file, which is then saved in the specified target directory.

SERVICES USED IN THIS SAMPLE PROCESS FLOW

This sample Process Flow illustrates the use of following services of Adeptia Suite:

- File Source
- Scripted Service
- Text Schema
- Mapping
- Excel Schema
- Compression
- Put-Context-Var
- File Target

DESCRIPTION

This sample Process Flow can be outlined as below:

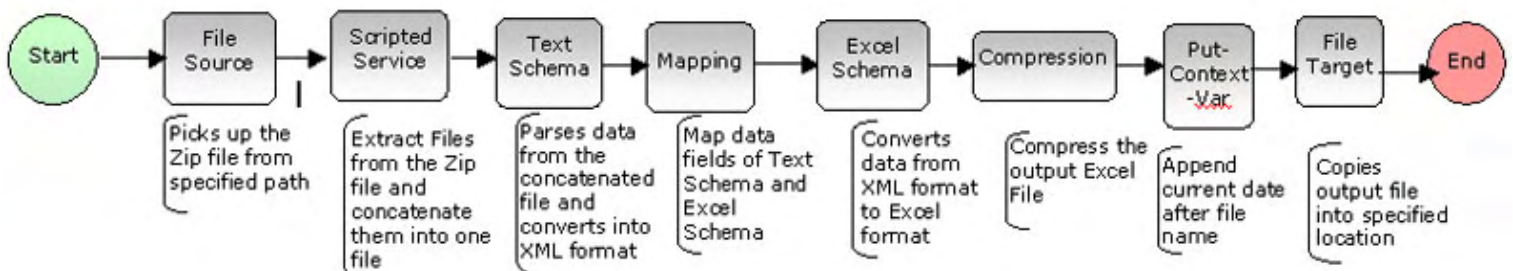

Figure 4.1: Flow Chart to Show Scripted Service Process Flow

File Source (EvalScript_FileSource)

File Source activity is used to specify a file, which is stored in local drive, as source. File Source picks up the specified file and passes it to the other activity. In this Process Flow, a Zip files that contains two files, is specified as source.

Scripted Service (EvalScript_ScriptedService)

Scripted Service is used to run any java code. You may want to perform some specific task, which may not be done by Adeptia Suite. In this case you can write your java code using scripted service. In this Process Flow, scripted service is used to extract files from a zip file and then concatenate them into a single text file.

Text Schema (EvalScript_TextSchema)

Text Schema is used to parse the data received from the file source and convert it into intermediate XML format.

Mapping (EvalScript_Mapping)

Mapping is used to map the data fields of Text Schema to the data fields of the Excel Schema. In this Process Flow simple one to one mapping is used.

Excel Schema (EvalScript_ExcelSchema)

Excel Schema is used to convert data from intermediate XML format to Excel format.

Compression

Compression is used to zip the output file. Compression is a Process Designer feature and used while creating the Process Flow. You do not have to create any such activity.

Put-Context-Variable

Put-Context-Variable is used to append current date with name of output Excel file. Put-Context-Var is a Process Designer feature and used while creating the Process Flow. You do not have to create any such activity.

File Target (EvalScript_FileTarget)

File Target is used to specify the name of the target zip file and the path, where the target zip file is to be saved.

USAGE SCENARIO

This Process Flow can be used, whenever you want to run any Java code to perform specific task.

DATA DESCRIPTION

Data used in this Process Flow contains record of employees of different departments of a company. At source end, a zip file is used which contains two different text files. Both the files are extracted from the zip file, concatenated and converted into Excel format.

The structure of text file used as source is outlined in the table below.

Table 4.1: Structure of Text File used as Source

Field Name	Description	Data Type
Name	Name of the employee	String
Address	Address of the employee	String
EmailID	Email address of the employee	String
PhoneNo	Contact Number of the employee	Number
DateOfBirth	Date of Birth of the employee	Date
Department	Department of the employee	String
Salary	Salary of the employee	Number
DateOfJoining	Date of joining of the employee	Date
Designation	Designation of the employee	String
Age	Age of the employee	Number

Name of the fields of the target file are same.

EXECUTING AND MONITORING

This section describes the execution of sample Process Flow and its monitoring.

Steps to execute the Process Flow:

1. In the Adeptia Suite homepage menu, click **[+] Design** to expand the tree. All the items in the **Design** category are displayed.
2. Click **[+] Process Flow** to expand the tree and then click **Process Flow**. The Manage Process Flow screen is displayed.
3. Select the radio button adjacent to *EvalScript_ProcessFlow* Process Flow and then click **Execute** link. The View Process Flow Log screen is displayed (refer to Figure 3.2).
4. Click the link **Process Flow Logs** to view the status of the Process Flow execution. The Process Flow Logs is displayed (see Figure 4.2).

Reports > Process Flow Log

Search Criteria

Start Date: 09/29/2007 Start Time: 00:00 End Date: 09/29/2007 End Time: 23:59

Process Flow Name: Select All Sort By Name Status: Executed Details Summary

Activity Name	Activity Type	Status	UserID	Start Time	End Time	Action
EvalScript_Mapping	DataMapping	Running	admin	09/29/2007 21:30:57	NA	Details Repository Summary Context Info
EvalScript_TextSchema	Stream2XmlStreamTransformer	Executed	admin	09/29/2007 21:30:56	09/29/2007 21:30:57	Details Repository Summary
EvalScript_TextSchema	Stream2XmlStreamTransformer	Running	admin	09/29/2007 21:30:56	NA	Details Repository Summary Context Info
EvalScript_ScriptedService	CustomPlugin	Executed	admin	09/29/2007 21:30:55	09/29/2007 21:30:56	Details Repository Summary
EvalScript_ScriptedService	CustomPlugin	Running	admin	09/29/2007 21:30:55	NA	Details Repository Summary Context Info
EvalScript_FileSource	FileSource	Executed	admin	09/29/2007 21:30:55	09/29/2007 21:30:55	Details Repository Summary
EvalScript_FileSource	FileSource	Running	admin	09/29/2007 21:30:55	NA	Details Repository Summary Context Info
EvalScript_ProcessFlow	Transaction	Running	admin	09/29/2007 21:30:55	NA	Details Repository Summary Context Info

Figure 4.2: Searched Process Flows

 To view the summary of all instances of the process flow execution, click the **Summary** button.

- Click **Details** under the **Action** column of the activity of which you want to view execution details. This displays the Detailed Process Flow Activity Execution screen (see Figure 4.3).

Process Flow Log Details

Process Flow Name : EvalScript_ProcessFlow
Process Flow PID : 192168001218118051042796800656

Date/Time	Activity Name	Activity Type	Status	Message	Level	Local...
05/30/2007 13:03:55	EvalScript_ProcessFlow	Transaction	Executed	Activity disposed. Start Time:2007-05-30 13:03:48 End Time:2007-05-30 13:03:55 Run Time:7 second(s) 94 ms	INFO	services.Abstrac...
05/30/2007 13:03:55	EvalScript_ProcessFlow	Transaction	Running	Context Information: {TransactionAddress=localhost://indigo.Transaction[192168001006115537870829600010] 19216800121811805 1042796800656};type=Transaction,name=EvalScript_ProcessFlow,id=192168001006115537870829600010,pid=192168001218118051042796800656, currentState=state-BPMN:TASK:BASIC_TASK-11053089, EvalScript_FileTarget,params={fileName=EvalScript_EmployeeData[2007-05-30].zip}, LoggingLevel=INFO}	INFO	services.Abstrac...
05/30/2007 13:03:55	EvalScript_FileTarget	FileTarget	Executed	Activity disposed. Start Time:2007-05-30 13:03:54 End Time:2007-05-30 13:03:55 Run Time:94 ms. Operation count:2307 Bytes Average:24542.553 operations/sec	INFO	services.Abstrac...
05/30/2007 13:03:55	EvalScript_FileTarget	FileTarget	Running	Execute	INFO	services.Abstrac...
05/30/2007 13:03:54	EvalScript_FileTarget	FileTarget	Running	Initialize	INFO	services.Abstrac...
05/30/2007 13:03:54	Compression	Compression	Executed	Activity disposed. Start Time:2007-05-30 13:03:53 End Time:2007-05-30 13:03:54 Run Time:1 second(s) 63 ms. Operation count:14848 bytes Average:13968.015 operations/sec	INFO	services.Abstrac...
05/30/2007 13:03:53	Compression	Compression	Running	Execute	INFO	services.Abstrac...
05/30/2007 13:03:53	Compression	Compression	Running	Initialize	INFO	services.Abstrac...
05/30/2007 13:03:53	EvalScript_ExcelSchema	XmlStream2StreamTransformer	Executed	Activity disposed. Start Time:2007-05-30 13:03:52 End Time:2007-05-30 13:03:53 Run Time:1 second(s) 140 ms. Operation count:9 Records Average:7.894737 operations/sec	INFO	services.Abstrac...
05/30/2007 13:03:52	EvalScript_ExcelSchema	XmlStream2StreamTransformer	Running	Execute	INFO	services.Abstrac...

Close Window

Figure 4.3: View Process Flow Log Details

EDITING ACTIVITIES

The activities used in this sample Process Flow are pre-created. This section describes how to edit these activities.

Editing File Source (EvalScript_FileSource)

File Source activity is used to specify a file, which is stored in local drive, as source. File Source picks up the specified file and passes it to the other activity. In this Process Flow, a Zip file (EvalScript_EmployeeData.zip) that contains two text files, is specified as source. This file is stored in `../../Solutions/Demo/EvalScript/Source` directory.

Steps to edit the File Source:

1. In the Adeptia Suite homepage menu, click **[+] Configure** to expand the tree. All the items in the **Configure** category are displayed.
2. Click **[+] Services** to expand the tree. All the items in the **Services** category are displayed.
3. Click **[+] Source** to expand the tree, and then click **File**. The Manage File Source screen is displayed with the list of existing File Source activities (see Figure 4.4).

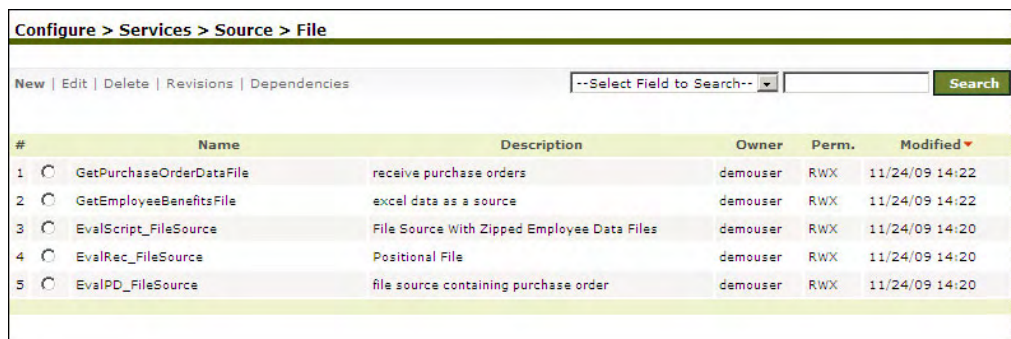

The screenshot shows a web interface titled "Configure > Services > Source > File". It includes a search bar with a dropdown menu labeled "--Select Field to Search--" and a "Search" button. Below the search bar is a table with the following data:

#	Name	Description	Owner	Perm.	Modified
1	<input type="radio"/> GetPurchaseOrderDataFile	receive purchase orders	demouser	RWX	11/24/09 14:22
2	<input type="radio"/> GetEmployeeBenefitsFile	excel data as a source	demouser	RWX	11/24/09 14:22
3	<input type="radio"/> EvalScript_FileSource	File Source With Zipped Employee Data Files	demouser	RWX	11/24/09 14:20
4	<input type="radio"/> EvalRec_FileSource	Positional File	demouser	RWX	11/24/09 14:20
5	<input type="radio"/> EvalPD_FileSource	file source containing purchase order	demouser	RWX	11/24/09 14:20

Figure 4.4: Manage File Source

4. Select the radio button adjacent to *EvalScript_FileSource* activity and then click **Edit** link. This displays the Edit *EvalScript_FileSource* activity screen, with the properties of the activity displayed in their respective fields (see Figure 4.5).

Configure > Services > Source > File > EvalScript_FileSource

[-] Standard properties

Name *

Description *

File Path *

File Name *

[+] Advanced properties

* Mandatory fields.

Save **Save As** **Cancel** **Test**

Figure 4.5: Edit *EvalScript_FileSource* Activity

A detailed description of fields on this screen is explicated in the table below.

Table 4.2: Details of Fields on Edit File Source Screen

Field Name	Field Description
Name	Name of the File Source
Description	Description of the File Source
File Path	Source Path of the source file. For example: ../../../../Solutions/Demo/EvalScript/
File Name	Name of the source file. For example: EvalScript_EmployeeData.Zip

5. Make the necessary changes.
6. Once you have made the required changes, click the **Save** button to save the changes. A screen is displayed confirming that the File Source Activity has been updated successfully. If the *comments* property is enabled, then clicking **Save** will display a screen where you need to enter comments related to updating the file source activity (refer to Figure 7.10).
7. Enter the comments in the *Add Comments* field.

 The comment should be at least 1 character in length.

8. Click **OK** to save the comments. This displays a screen confirming that the file source activity has been updated successfully.

 You can verify the file source activity at design time. For this, click **Test Connection**. This verifies the values in the *File Path* and *Filename* fields

and checks whether the file actually exists in the specified location.

Editing Scripted Service (EvalScript_ScriptedService)

Scripted Service is used to call any Java Code to perform specific task. In this Process Flow, Scripted Service is used to extract two files from a Zip file and then concatenate them into single file. The Java Code used in the scripted service is displayed in Figure 4.6:

```
import com.adeptia.indigo.services;
import java.io.InputStream;
import java.util.zip.ZipEntry;
import java.util.zip.ZipFile;
import java.util.zip.ZipInputStream;
import java.io.BufferedInputStream;

byte[] data=new byte[1];

//creating ZipInputStream from the stream passed from file source
ZipInputStream zin = new ZipInputStream(new
BufferedInputStream(inputStream));

ZipEntry entry;

//extracting each zip entry from ZipInputStream and writing to output stream
while((entry = zin.getNextEntry()) != null) {

//reading from the employee data files
    while ((count = zin.read(data)) != -1) {

//writing data into the output stream
        service.write(data ,"default");

    }
}
```

Figure 4.6: Sample JAVA Code

Steps to edit the Scripted Service:

1. In the Adeptia Suite homepage menu, click **[+] Configure** to expand the tree. All the items in the **Configure** category are displayed.
2. Click **[+] Services** to expand the tree. All the items in the **Services** category are displayed.
3. Click **[+] Extensions** to expand the tree, and then click **Custom Plugin**. The Manage Custom Plugin screen is displayed with the list of existing custom plugin activities (see Figure 4.7).

Configure > Services > Extensions > Custom Plugin					
New Edit Delete Revisions Dependencies					
--Select Field to Search--					Search
#	Name	Description	Owner	Perm.	Modified
1	<input type="radio"/> EvalScript_ScriptedService	Scripted Service to Concatenate Employee Records	demouser	RWX	08/10/05 12:57

Figure 4.7: Manage Custom Plugins

4. Select the radio button adjacent to *EvalScript_ScriptedService* activity and then click **Edit** link. This displays the Edit *EvalScript_ScriptedService* activity screen, with the properties of the activity displayed in their respective fields (see Figure 4.8).

Configure > Services > Extensions > Custom Plugin > EvalScript_ScriptedService	
[-] Standard properties	
Name *	EvalScript_ScriptedService
Description *	Scripted Service to Concatenate Em
Script *	<pre>import com.adeptia.indigo.services; import java.io.InputStream; import java.util.zip.ZipEntry; import java.util.zip.ZipFile; import java.util.zip.ZipInputStream; import java.io.BufferedInputStream; byte[] data=new byte[1]; ZipInputStream zin = new ZipInputStream(new BufferedInputStream(inputStream)); ZipEntry entry; while((entry = zin.getNextEntry()) != null) { //reading from the employee data files while ((count = zin.read(data)) != -1) { service.write(data ,"default"); } }</pre>
[+] Advanced properties	
* Mandatory fields.	
Save	Save As
Cancel	

Figure 4.8: Edit *EvalScript_ScriptedService* Activity

The detailed description of fields on this screen is explicated in the table below.

Table 4.3: Details of Fields on Edit Custom Plugin Screen

Field Name	Field Description
Name	Name of the Scripted Service
Description	Description of the Scripted Service
Script	Java Code that you want to run to perform the specific task

5. Make the necessary changes.
6. Once you have made the required changes, click the **Save** button to save the changes. A screen is displayed confirming that the custom plugin activity has been updated successfully. If the *comments* property is enabled, then clicking **Save** will display a screen where you need to enter comments related to updating the custom plugin activity (refer to Figure 7.10).
7. Enter the comments in the *Add Comments* field.

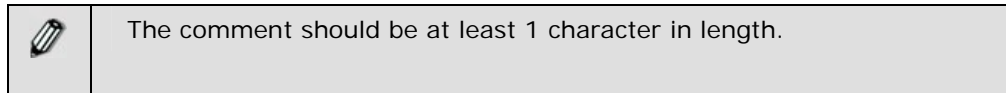

8. Click **OK** to save the comments. This displays a screen confirming that the custom plugin activity has been updated successfully.

Editing Text Schema (EvalScript_TextSchema)

Text Schema describes the structure of a text file. Text Schema activity is used to define how a text file is read or written in a predefined format. To create a Text Schema activity, you need to specify the record separator, field separator and the field names of the text file.

Steps to edit the Text Schema:

1. In the Adeptia Suite homepage menu, click **[+] Configure** to expand the tree. All the items in the **Configure** category are displayed.
2. Click **[+] Services** to expand the tree. All the items in the **Services** category are displayed.
3. Click **[+] Schema** to expand the tree, and then click **Text**. The Manage Text Schema screen is displayed with the list of existing Text Schema activities (refer to Figure 7.12)
4. Select the radio button adjacent to *EvalScript_TextSchema* activity and then click **Edit** link. This displays the Edit *EvalScript_TextSchema* activity screen, with the properties of the activity displayed in their respected fields (see Figure 4.9).

Configure > Services > Schema > Text > EvalScript_TextSchema

[-] Standard properties

Name *

Description *

Data Header Present

Record Separator*

Field Separator*

Download Schema Definition File Download

Create Schema Definition*

Use Definition File Upload File

Enter the Fields Sequentially

#	FieldName	Type	DateFormat	TimeFormat
1	<input type="text" value="NAME"/>	<input type="text" value="string"/>	<input type="text" value="mmdyyyy"/>	<input type="text" value="hh:mm:ss"/>
2	<input type="text" value="ADDRESS"/>	<input type="text" value="string"/>	<input type="text" value="mmdyyyy"/>	<input type="text" value="hh:mm:ss"/>
3	<input type="text" value="EMAILID"/>	<input type="text" value="string"/>	<input type="text" value="mmdyyyy"/>	<input type="text" value="hh:mm:ss"/>
4	<input type="text" value="PHONENO"/>	<input type="text" value="number"/>	<input type="text" value="mmdyyyy"/>	<input type="text" value="hh:mm:ss"/>

Number of Rows at Position Add Row Remove Row

[+] Advanced properties

* Mandatory fields.

Save
Save As
Cancel
Test

Figure 4.9: Edit *EvalScript_TextSchema* Activity

A detailed description of fields on this screen is explicated in the table below.

Table 4.4: Details of Fields on Edit Text Schema Screen

Field Name	Field Description
Name	Name of the Text Schema activity
Description	Description of the Text Schema activity
Data Header Present	Data Header usually contains the titles of the fields in a text file. If data header is present in the text file, check the Data Header Present checkbox
Record Separator	Character or set of characters that are used to mark the end of a record. For Example \n for New Line .
Field Separator	Character or set of characters that are used to separate fields. For example \t for TAB
Download Schema Definition File	To download a schema definition file, click Download button. Else, you can create a new schema definition.
Create Schema Definition	Schema can be defined using one of the following options: <ul style="list-style-type: none"> ▪ Use Definition File

	<ul style="list-style-type: none"> Enter the Fields Sequentially <p>Pre-created schema with this sample Process Flow is created using second option i.e. Enter the Field Sequentially</p>
Field Name	Name of the Fields
Data Type	There are three data types:
	<p>String String can be used for any type of data.</p> <p>Number Contains numbers</p> <p>Date Contains Date and Time</p>
Quotes Handling On	<p>Suppose a character (say \$) is specified as Field Separator in a record. Now any \$ character in data field of that record (Chocolate\$20\$perpack) is considered as Field Separator, even though it is part of the data field. In the above example the \$ after 20 is also considered as Field Separator, whereas it is data. To avoid this situation put those fields within the double quotes i.e. (Chocolate"\$20\$perpack") and check Quotes Handling On checkbox. Now characters within double quotes are considered as one Field even though there is a \$ sign.</p> <p>This option is available in <i>Advanced Properties</i> of Text Schema.</p>

- Make the necessary changes.
- Once you have made the required changes, click the **Save** button to save the changes. A screen is displayed confirming that the Text Schema activity has been updated successfully. If the *comments* property is enabled, then clicking **Save** will display a screen where you need to enter comments related to updating the text schema activity (refer to Figure 7.10).
- Enter the comments in the *Add Comments* field.

	The comment should be at least 1 character in length.
---	---

- Click **OK** to save the comments. This displays a screen confirming that the text schema activity has been updated successfully.

Testing Text Schema (EvalScript_TextSchema)

You can verify the text schema activity at design time.

Steps to verify schema activity

- Click **Test** button on the Edit Text Schema screen. The Test Schema screen is displayed (refer to Figure 7.14).
- Select the type of schema to test, from the *Type* drop-down list. By default, *Source* is selected.

3. Enter the full path (with file name) of the source file in the *Source File Name* field.
4. Enter the full path of the XML target file, where it will be generated, in the *Target File Name* field.
5. Enter the full path of the XML file where errors will be stored, in the *Error File Name* field.
6. Click **Submit** button. This tests the validity of the text schema.

Editing Mapping (EvalScript_Mapping)

Mapping is used to map data fields of source Schema with the data fields of target Schema. In this sample Process Flow simple one to one mapping is used.

Steps to edit the Mapping activity:

1. In the Adeptia Suite homepage menu, click **[+] Configure** to expand the tree. All the items in the **Configure** category are displayed.
2. Click **[+] Services** to expand the tree. All the items in the **Services** category are displayed.
3. Click **[+] Data Transform** to expand the tree, and then click **Data Mapping**. The Manage Data Mapping screen is displayed. The Manage Data Mapping screen is displayed with the list of existing mapping activities (refer to Figure 7.15).
4. Select the radio button adjacent to *EvalScript_Mapping* activity and then click **Edit** link. This displays the Edit *EvalScript_Mapping* activity screen, with the name and description of the activity displayed in their respective fields (see Figure 4.10).

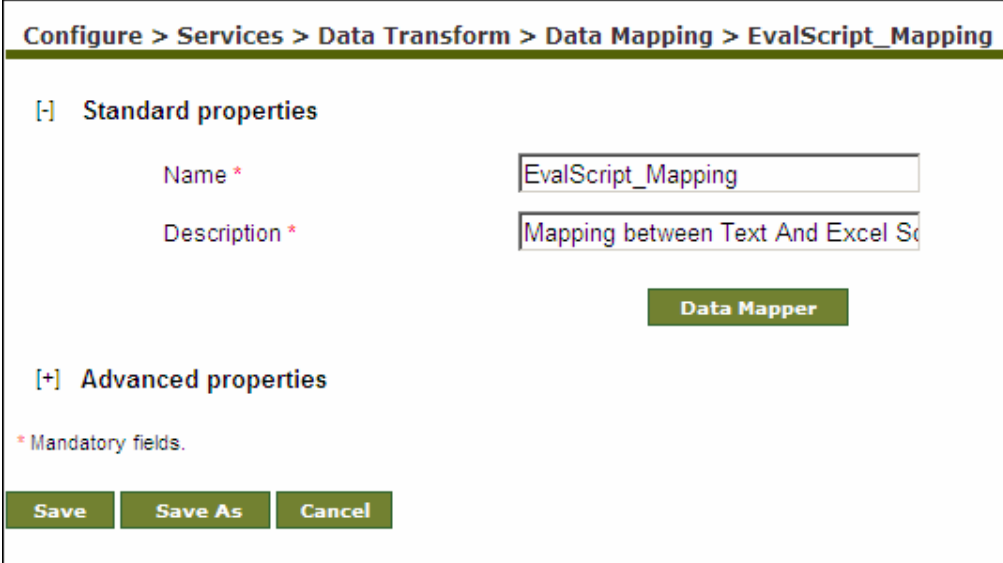

Configure > Services > Data Transform > Data Mapping > EvalScript_Mapping

[-] Standard properties

Name *

Description *

Data Mapper

[+] Advanced properties

* Mandatory fields.

Save Save As Cancel

Figure 4.10: Edit *EvalScript_Mapping* Activity

- Click the **Data Mapper** button. The Data Mapper applet is displayed showing mapping between the data fields of source and target schema (see Figure 4.11).

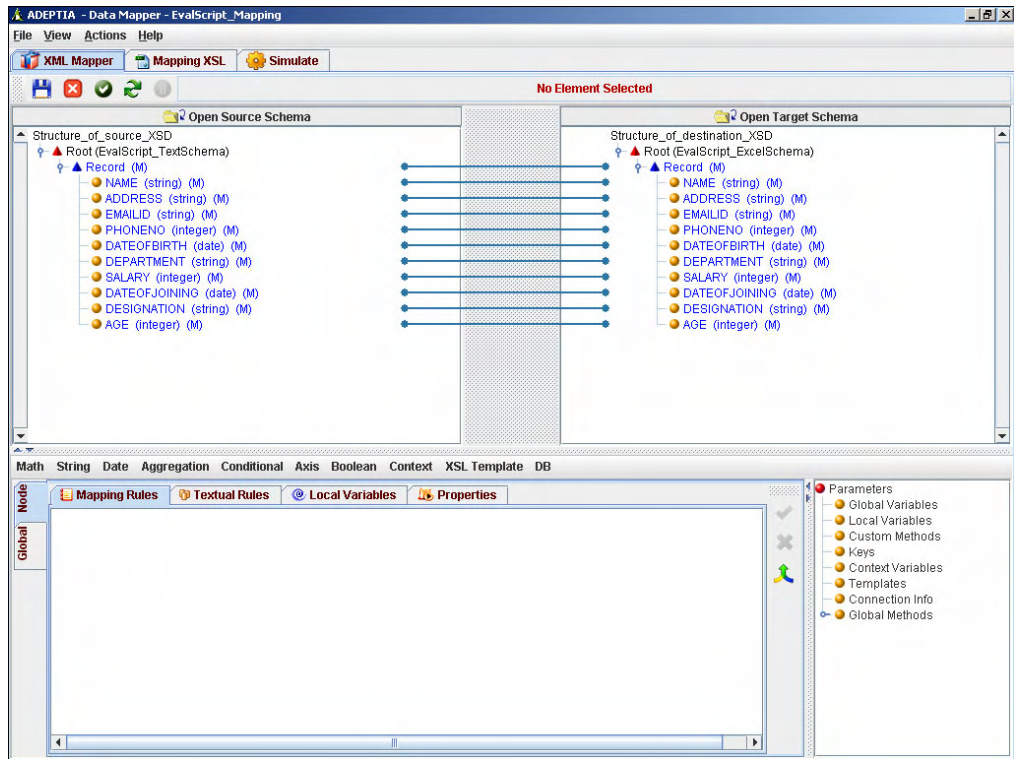





Figure 4.11: *EvalScript_Mapping* Activity in Data Mapper

- Make the necessary changes to the mapping between the source and target schemas.
- Once you have made the required changes, save the mapping by clicking **File** menu and selecting **Save**. A dialog box is displayed confirming that the Mapping activity has been saved successfully.

	<p>Alternately, you can save the mapping activity by clicking Save () button on the Tool Bar.</p>
---	---

- If the *comments* property is enabled, then clicking **Save** will display a screen where you need to enter comments related to the mapping (refer to Figure 7.18).
- Enter the comments in the *Specify comments for mapping object (object name)* field.

	<p>The comment should be at least 1 character in length.</p>
---	--

10. Click **OK** to save the comments. This displays a dialog box confirming that the mapping has been saved successfully.
11. Exit the Data Mapper applet by clicking **File** menu and selecting **Exit**.

Editing Excel Schema (EvalScript_ExcelSchema)

Excel Schema defines the structure of Excel file. Excel Schema defines how the data can be read from an excel sheet or how it can be written into an excel sheet. In this sample Process Flow, Excel schema is used at the target end. At target end Excel Schema converts the data from an intermediate XML format into Excel format.

Steps to edit the Excel Schema activity:

1. In the Adeptia Suite homepage menu, click **[+] Configure** to expand the tree. All the items in the **Configure** category are displayed.
2. Click **[+] Services** to expand the tree. All the items in the **Services** category are displayed.
3. Click **[+] Schema** to expand the tree, and then click **Excel**. The Manage Excel Schema screen is displayed with the list of existing Excel Schemas (refer to Figure 3.15).
4. Select the radio button adjacent to *EvalScript_ExcelSchema* activity and then click **Edit** link. This displays the Edit *EvalScript_ExcelSchema* activity screen, with the properties of the activity displayed in their respective fields (see Figure 4.12).

Configure > Services > Schema > Excel > EvalScript_ExcelSchema

[-] Standard properties

Name *

Description *

Data Header Present

Download Schema Definition File

Create Schema Definition*

Use Definition File

Enter the Fields Sequentially

Sheet Name*

#	FieldName	Type	Format	SubFormat	Data Mode
1	<input type="text" value="NAME"/>	string	mmddyyyy	hh:mm:ss	Plain Text
2	<input type="text" value="ADDRESS"/>	string	mmddyyyy	hh:mm:ss	Plain Text
3	<input type="text" value="EMAILID"/>	string	mmddyyyy	hh:mm:ss	Plain Text
4	<input type="text" value="PHONENO"/>	number	mmddyyyy	hh:mm:ss	Plain Text

Number of Rows at Position

Define Hierarchy

[+] Advanced properties

* Mandatory fields.

Figure 4.12: Edit *EvalScript_ExcelSchema* Activity

A detailed description of fields on this screen is explicated in the table below.

Table 4.5: Details of Fields on Edit Excel Schema Screen

Field Name	Field Description
Name	Name of the Excel Schema
Description	Description of the Excel Schema
Data Header Present	Data Header usually contains the titles of the fields in a file. If you enable this option, Field Names of Excel Schema are written as column's name in target excel file
Sheet Name	Name specified here becomes the Book Name of the excel sheet.
Download Schema Definition File	To download an existing schema definition file, click Download button. Else, you can create a new schema definition.
Create Schema Definition	Schema can be defined using one of the following options: <ul style="list-style-type: none"> Use Definition File Enter the Field Sequentially Pre-created schema with this sample Process Flow is created using second option i.e. Enter the Field Sequentially

Field Name	Name of the Fields
Data Type	There are three data types:
	String String can be used for any type of data.
	Number Contains numbers
	Date Contains Date and Time
	Currency Contains Currency Value
Format	If data type is <i>Date</i> , select the data format from <i>Format</i> drop-down list.
SubFormat	If data type is <i>Date</i> , select time format from <i>SubFormat</i> drop-down list.
Data Mode	If data is in Plain Text, select <i>Plain Text</i> option. If data is encrypted, then select <i>Encrypted</i> option.

5. Make the necessary changes.
6. Once you have made the required changes, click the **Save** button to save the changes. A screen is displayed confirming that the Excel Schema has been updated successfully. If the *comments* property is enabled, then clicking **Save** will display a screen where you need to enter comments related to updating the excel schema (refer to Figure 7.10).
7. Enter the comments in the *Add Comments* field.

	The comment should be at least 1 character in length.
---	---

8. Click **OK** to save the comments. This displays a screen confirming that the excel schema has been updated successfully.

Editing File Target

(EvalScript_FileTarget)

File target is used to specify the name of the target file and path, where the target file is saved. In this sample Process Flow, target file is saved in **../../Solutions/Demo/EvalScript/** directory.

Steps to edit the File Target:

1. In the Adeptia Suite homepage menu, click **[+] Configure** to expand the tree. All the items in the **Design** category are displayed.
2. Click **[+] Configure** to expand the tree. All the items in the **Services** category are displayed.
3. Click **[+] Target** to expand the tree, and then click **File**. The Manage File Target screen is displayed with the list of existing File Target activities (refer to Figure 3.17).
4. Select the radio button adjacent to *EvalScript_FileTarget* activity and then click **Edit** link. This displays the Edit *EvalScript_FileTarget* activity screen, with the properties of the activity displayed in their respective fields (see Figure 4.13).

Configure > Services > Target > File > EvalScript_FileTarget

[-] Standard properties

Name *

Description *

File Path *

File Name *

[+] Advanced properties

* Mandatory fields.

Save Save As Cancel Test

Figure 4.13: Edit *EvalScript_FileTarget* Activity

A detailed description of fields on this screen is explicated in the table below.

Table 6.6 Details of Fields on Edit File Target Screen

Field Name	Field Description
Name	Name of the File Target
Description	Description of the File Target
File Path	Target Path and the target file. For example: ../../Solutions/Demo/EvalScript/
File Name	Name of target file. For example: EvalScript_CompleteEmployeeData.zip

5. Make the necessary changes.
6. Once you have the made the required changes, click the **Save** button to save the changes. A screen is displayed confirming that the File Target Activity has been updated successfully. If the *comments* property is enabled, then clicking **Save** will display a screen where you need to enter comments related to updating the file target activity (refer to Figure 7.10).
7. Enter the comments in the *Add Comments* field.

 The comment should be at least 1 character in length.

8. Click **OK** to save the comments. This displays a screen confirming that the file target activity has been updated successfully.

 You can verify the file target activity at design time. For this, click **Test Connection**. This verifies the values in the *Path* field and checks whether

the file actually exists in the specified location.

CREATING PROCESS FLOW

(EvalScript_ProcessFlow)

Process Flow is the set of activities arranged in a sequence to perform a specific task(s). Process Flow is created by combining various activities such as Source, Target, Schema or Transformer activities in a logical sequence. Process Designer is used to create a Process Flow. Process Designer has list of activities created. You only need to arrange them in a logical sequence and connect them with BPMN Flows.

Steps to create EvalScript_ProcessFlow:

1. In the Adeptia Suite homepage menu, click **[+] Design** to expand the tree. All the items in the **Design** category are displayed.
2. Click **[+] Process Flow** to expand the tree and then click **Process Flow**. The Manage Process Flow screen is displayed with the list of existing Process Flows (refer to Figure 7.27).
3. Click the **New** link. The Create Process Flow screen is displayed (refer to Figure 7.28).
4. Enter the name and the description of the new Process Flow in the *Name* and *Description* fields respectively.
5. Select the logging level from the *Logging Level* drop-down list. There are four level of logging. They are described in Table 7.9.
6. Select repository file retention from the *Repository File Retention* option. During execution Process Flow creates a temporary repository file to store the intermediate data. These repository files can cause unnecessary disk space usage and you may want to delete them after execution of the Process Flow. On the other hand sometime these repository files can be helpful in case of failure of Process Flow execution. For each instance of the Process Flow execution a unique repository folder is created that contains Source, intermediate XML data files and target formatted data. By default repository files are being stored in the repository folder of the Adeptia Suite. You can also choose an option to delete them or to archive them in a different location. There are four options for the Repository File Retention. They are described in Table 7.10.
7. Click the **Process Designer** button to open Process Designer. The Process Designer Screen is displayed (refer to Figure 7.29).
8. Once the Process Designer screen is displayed, a message to synchronize the list of activities and Process Flow with the Adeptia Suite is displayed. Click **OK** to synchronize.



Alternately, you can synchronize the list of activities and Process Flow with the Adeptia Suite by clicking the **Synchronize** () button displayed on the Tool Bar.



9. Click **[+] Activities** in Repository View, to expand the list of services and then click **[+] Source**. All the items in the **Source** category are displayed.
10. Click **[+] File Source**. A list of existing File Source activities is displayed.
11. Select **EvalScript_FileSource** and drag it to the Graph Canvas Area (see Figure 4.14).

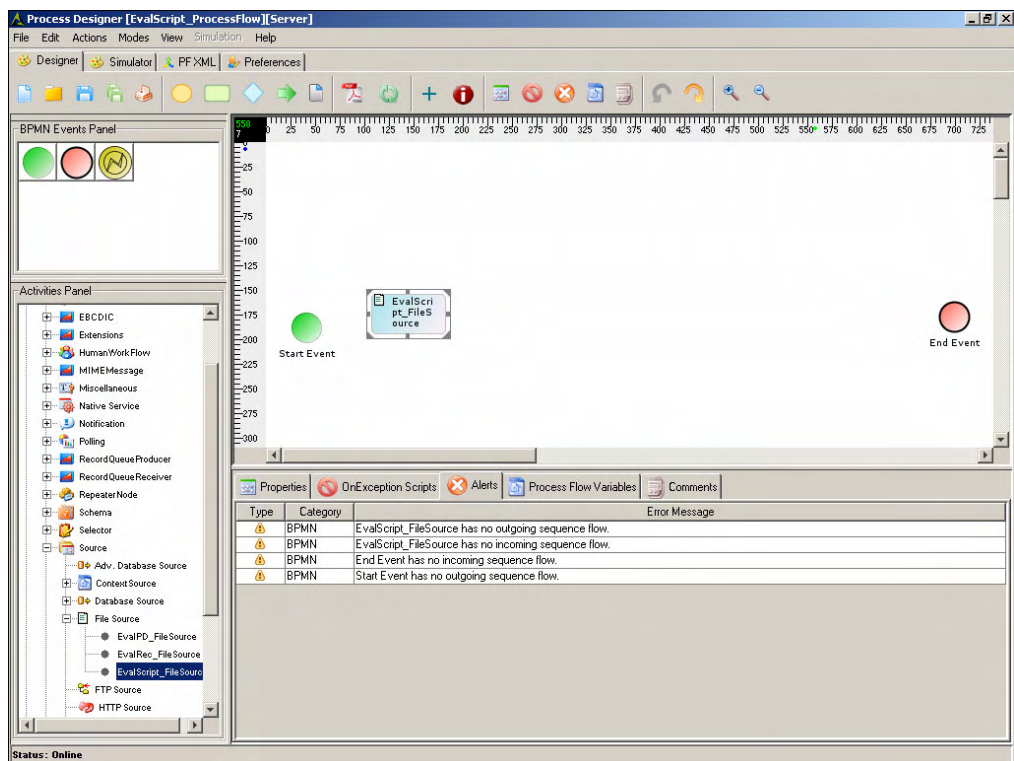

Figure 4.14: Drag File Source to Graph Canvas Area

12. Similarly, click **[+] Extensions** and then **[+] Custom Plugin**. Select **EvalScript_ScriptedService** activity and drag it to the Graph Canvas Area.
13. Click **[+] Schema** and then **[+] Text Schema**. Select **EvalScript_TextSchema** activity and drag it to the Graph Canvas Area.
14. Click **[+] DataTransform** and then **[+] Data Mapping**. Select **EvalScript_Mapping** activity and drag it to the Graph Canvas Area.
15. Click **[+] Schema** and then **[+] Excel Schema**. Select **EvalScript_ExcelSchema** activity and drag it to the Graph Canvas Area.
16. Right-click **EvalScript_ExcelSchema** in the Repository View, and select **View Server Properties**. Properties of *EvalScript_ExcelSchema* are shown in the bottom pane (see Figure 4.15).

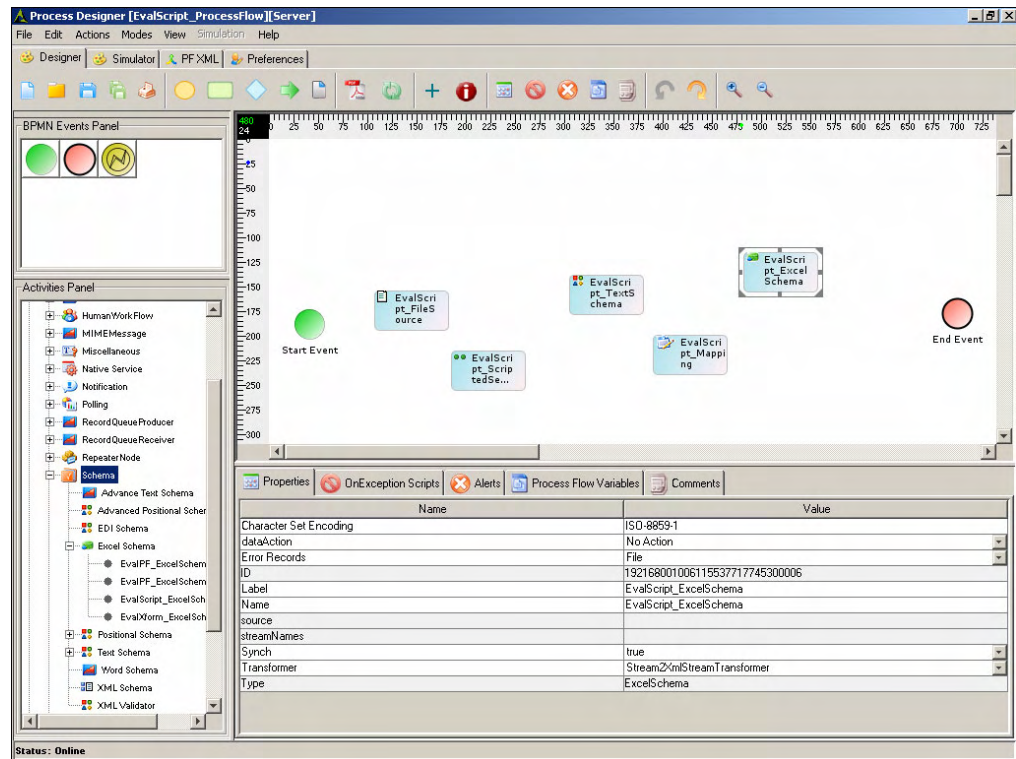



Figure 4.15: View Properties of *EvalScript_ExcelSchema* Activity

17. The value of Transformer property is set to **Stream2xmlStream Transformer**. Click the value box and change it to **XmlStream2StreamTransformer**. When schema is used at target end, its transformer type must be **XmlStream2Stream Transformer**.
18. Click **[+] Compression Service** to expand it. Select **Compression** and drag it to the Graph Canvas Area.
19. Click **[+] Action** in Repository View, to expand the list of Actions.



An Action name is always unique.

20. Select **Put-Context-Var** and drag it to the Graph Canvas Area (see Figure 4.16).

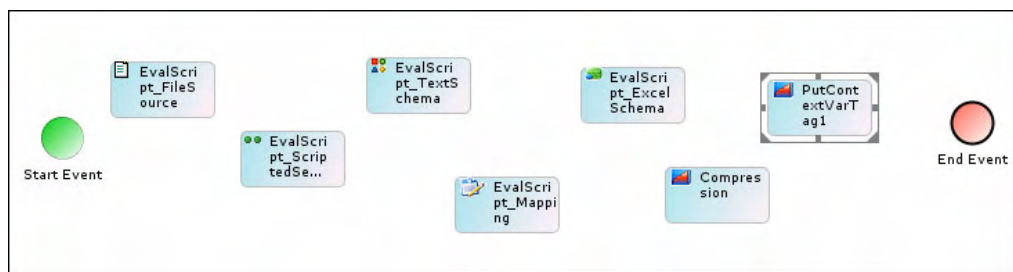

Figure 4.16: Drag Put-Context Var to Graph Canvas Area

21. Click **[+] Target** and then **[+] File Target**. Select **EvalScript_FileTarget** activity and drag it to the Graph Canvas Area.
22. Once all the activities are dragged to the Graph Canvas Area, they must be connected using appropriate BPMN Flows or Control Flows.
23. Click the **Sequence Flow** (→) icon from the Palette. The Sequence flow is selected.
24. Drag mouse pointer from *Start Event* to *EvalScript_FileSource* to connect *Start Event* with *EvalScript_FileSource* (see Figure 4.17).

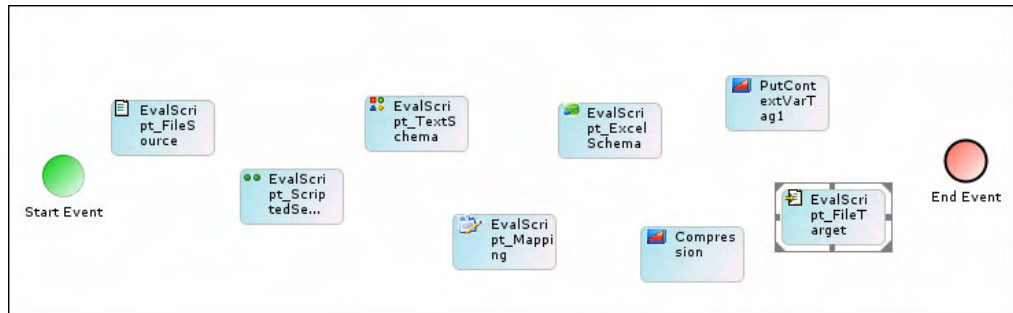

Figure 4.17: Connect Start Event to File Source

25. Similarly, connect all other activities as shown in Figure 4.18.

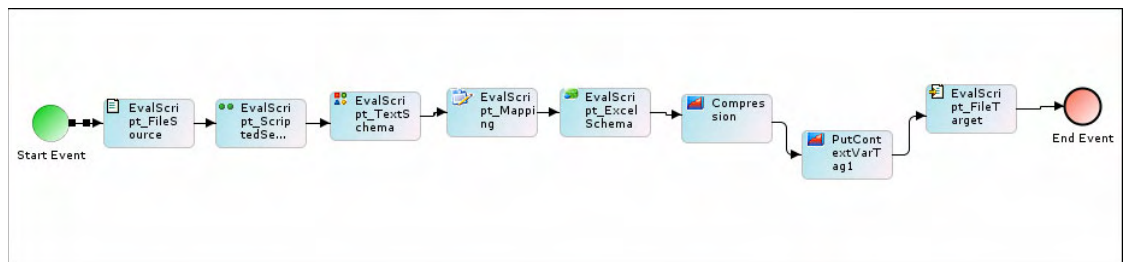

Figure 4.18: Connect all Activities

26. To add current date after the target file name, right-click **Put-Context-Var** and select **View Properties**. Properties of *Put-Context-Var* are shown in the Properties Panel (see Figure 4.19).

Properties OnException Scripts Alerts Process Flow Variables Comments				
Name		Value		
Context Variables		Edit		
Label		PutContextVarTag1		
Name		PutContextVarTag1		
Type		Put-Context-Var		

Figure 4.19: View Put-Context Var Properties

27. Click **Edit** from the value field of the *context Variable* properties. The *Edit Context Variable* screen is displayed (see Figure 4.20).

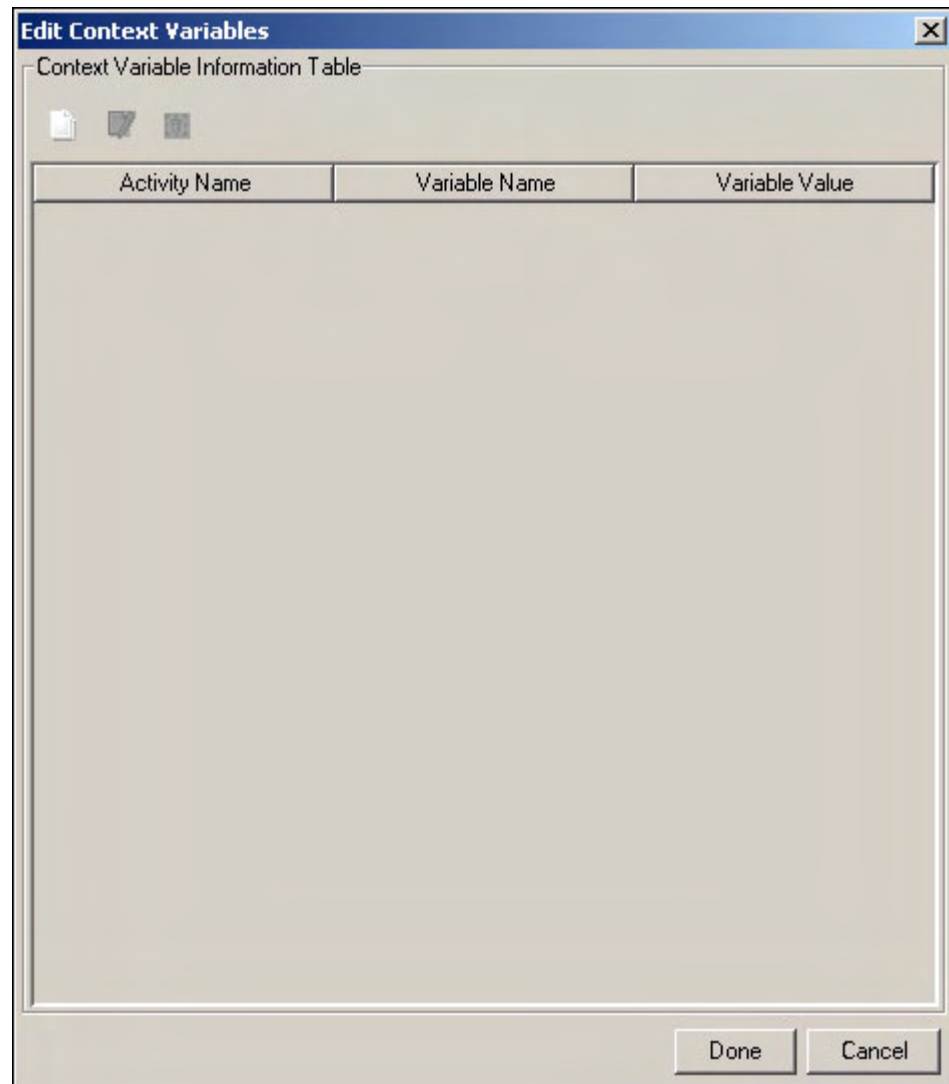

Figure 4.20: Edit Context Variable

28. Click **New variable**  button. The *Context Variable Information* dialog box is displayed (see Figure 4.21).

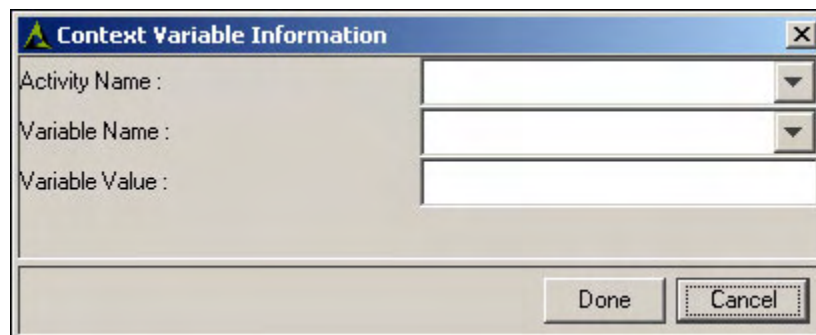

Figure 4.21: Add Context Variable

29. In the *Activity* drop-down list select the *EvalScript_FileTarget* activity.
30. Enter *filename* in the *Key* box.
31. Enter the name of the target file with date and time format in the *Value* box.

For example: *EvalScript_CompleteEmployeeData[%%yyyy-mm-dd%].zip*



If the target file is saved on 2005-02-05, name of the file will be *EvalScript_EmployeeData[2005-02-05].zip*.

32. Click **Done** twice to return to Graph Canvas Area.



Figure 6.18 shows only the control flow of the Process Flow. Control Flows only shows the order in which activities of a Process Flow is executed. It does not show the flow of data. For example as you can see in the figure 6.18, control flow from Compression goes to Put-Context-Var. But data is not passed from Compression to Put-Context-Var. Data is directly passed from Compression to EvalScript_FileTarget activity. To create the data flow, you need to create data stream between Compression and EvalScript_FileTarget.

33. To create data stream, right-click **Compression** and select **Multiple Stream**. The Multiple Stream dialog box is displayed (see Figure 4.22).

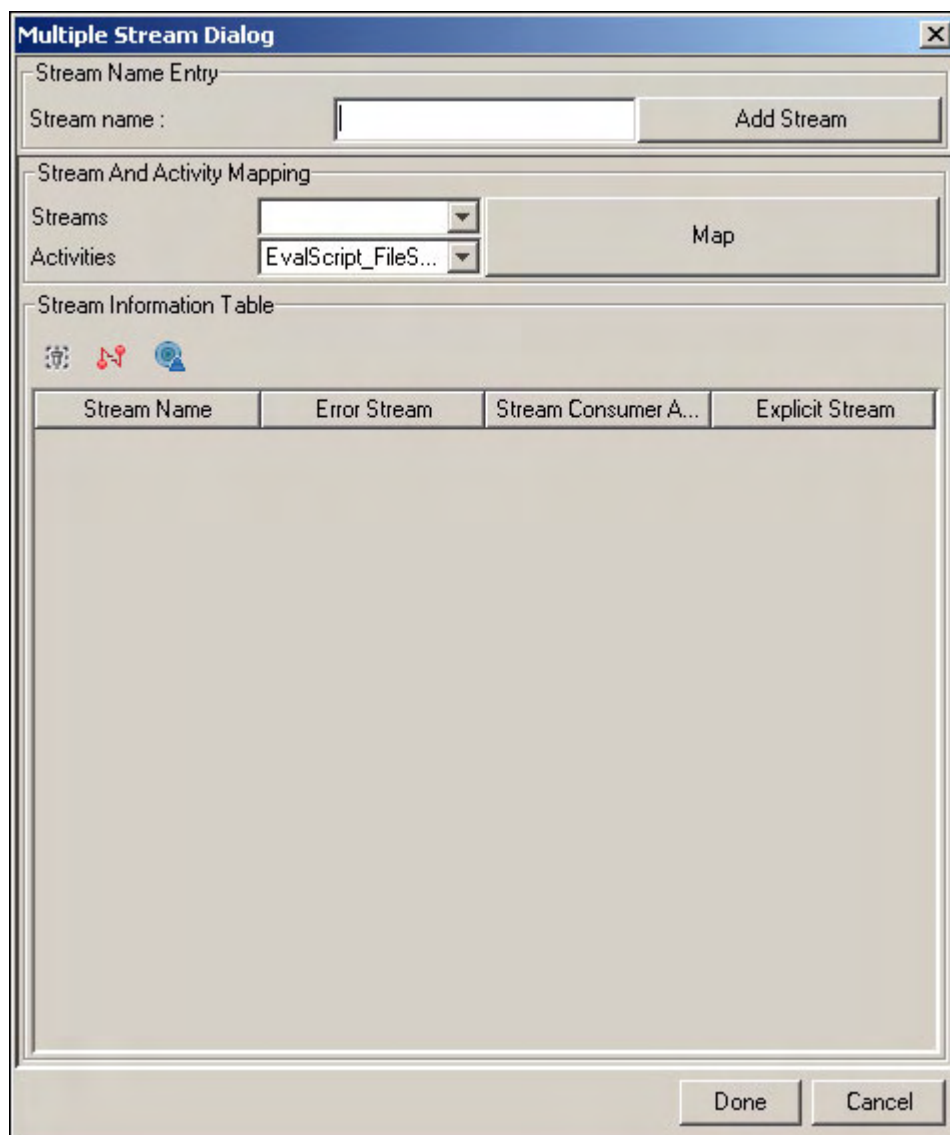



Figure 4.22: Multiple Stream Dialog Box

34. Select **EvalScript_FileTarget** from the *Activities* drop-down list and then click the **Default Stream** () button.
35. Click the **Map** button. A stream between *Compression* and *EvalScript_FileTarget* is created (see Figure 4.23).

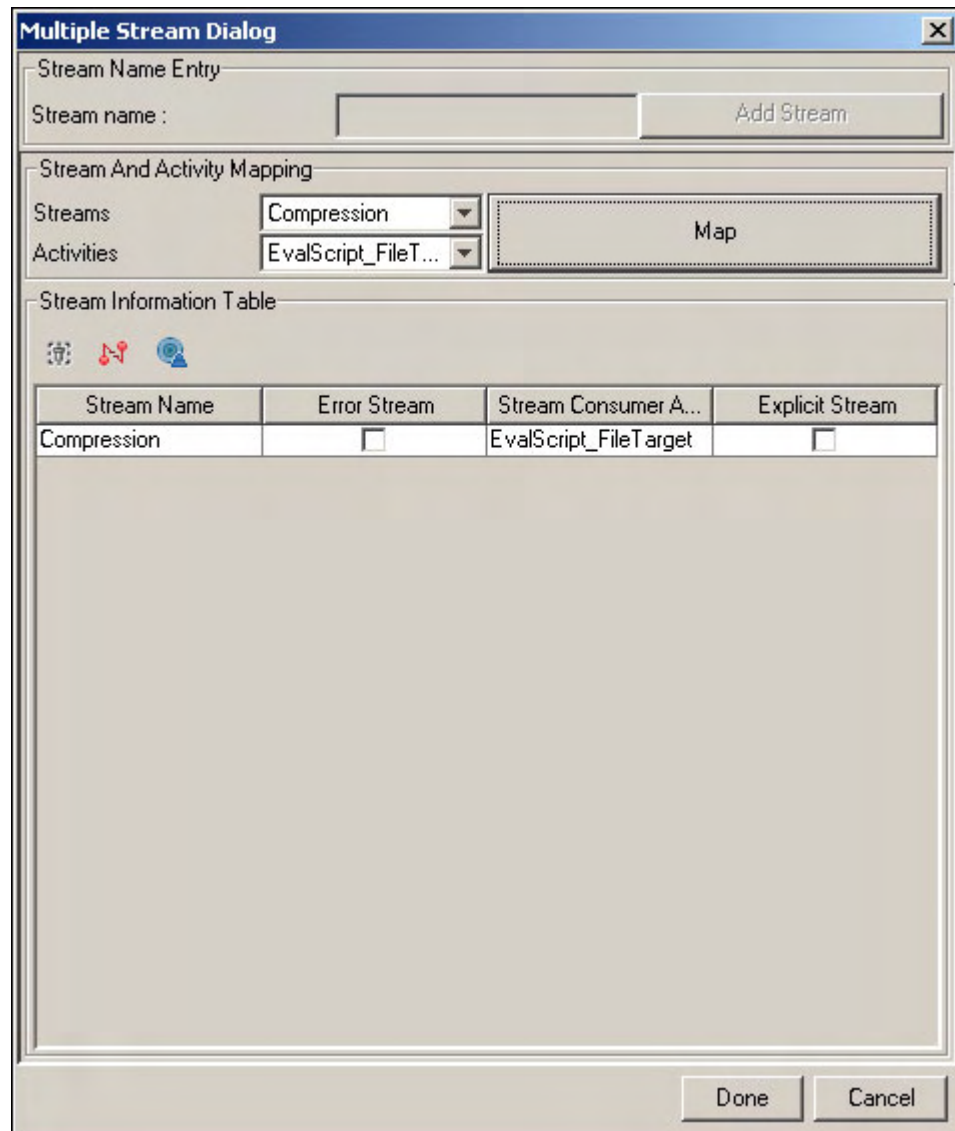

Figure 4.23: Define Data Stream

36. Check the *Explicit Stream* checkbox.
37. Click **Done** button to close the Multiple Stream Dialog box. Data stream created is shown in the Graph Canvas area (see Figure 4.24).

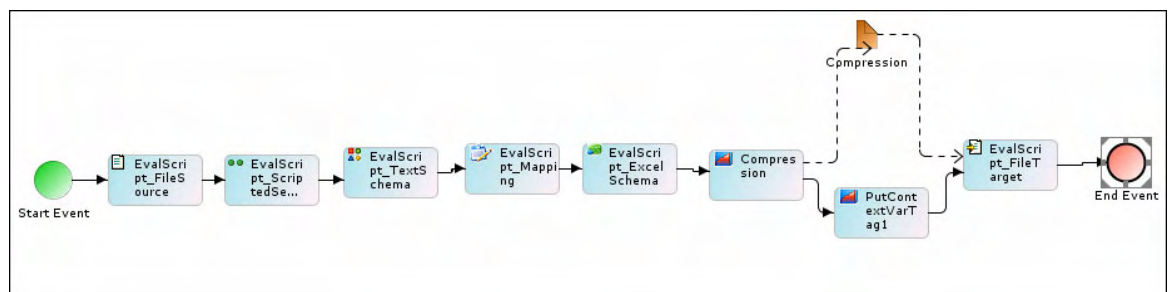

Figure 4.24: Data Stream Created

38. Save the Process Flow by clicking **File** menu and selecting **Save Process Flow to Server**. A dialog box is displayed confirming that the *EvalScript_ProcessFlow* has been saved successfully. If the *comments* property is enabled, then clicking **Save Process Flow to Server** will display a screen where you need to enter comments related to creating the process flow (refer to Figure 7.37).
39. Enter the comments in the *Specify Comments for process flow* field.



The comment should be at least 1 character in length.

40. Click **OK** to save the comments. This displays a screen confirming that the process flow has been created successfully.
41. Click the **Done** button to close the dialog box.
42. Exit the Process Designer by clicking **File** menu and selecting **Exit**.

5 PROCESS DESIGNER PROCESS FLOW

This section describes the Process Designer Process Flow.

In the Adeptia Suite this process flow is available in:

BPM Suite	Workflow Suite	Integration Suite	ETL Suite
√		√	√

INTRODUCTION

This Process Flow demonstrates the use of different features of Process Designer. In this Process Flow, a purchase order, which is in text format, is used as source. Values of the purchase order (i.e. PO Number, Amount, Company Name, and Item) are separated by comma (.). A copy of the purchase order is saved into a specified folder. Another copy of the purchase order is sent to either of the Manager or Director of the company through email. If the purchase amount is less than US\$ 50000, the purchase order is sent to the Manager for approval. If the purchase amount is greater than US\$ 50000, the purchase order is sent to the Director for approval.

SERVICES USED IN THIS SAMPLE PROCESS FLOW

This sample Process Flow illustrates the use of following services of Adeptia Suite:

- File Source
- Context Target
- Context Source
- Repeater
- File target
- Decision Node
- Mail Target

DESCRIPTION

This sample Process Flow can be outlined as below:

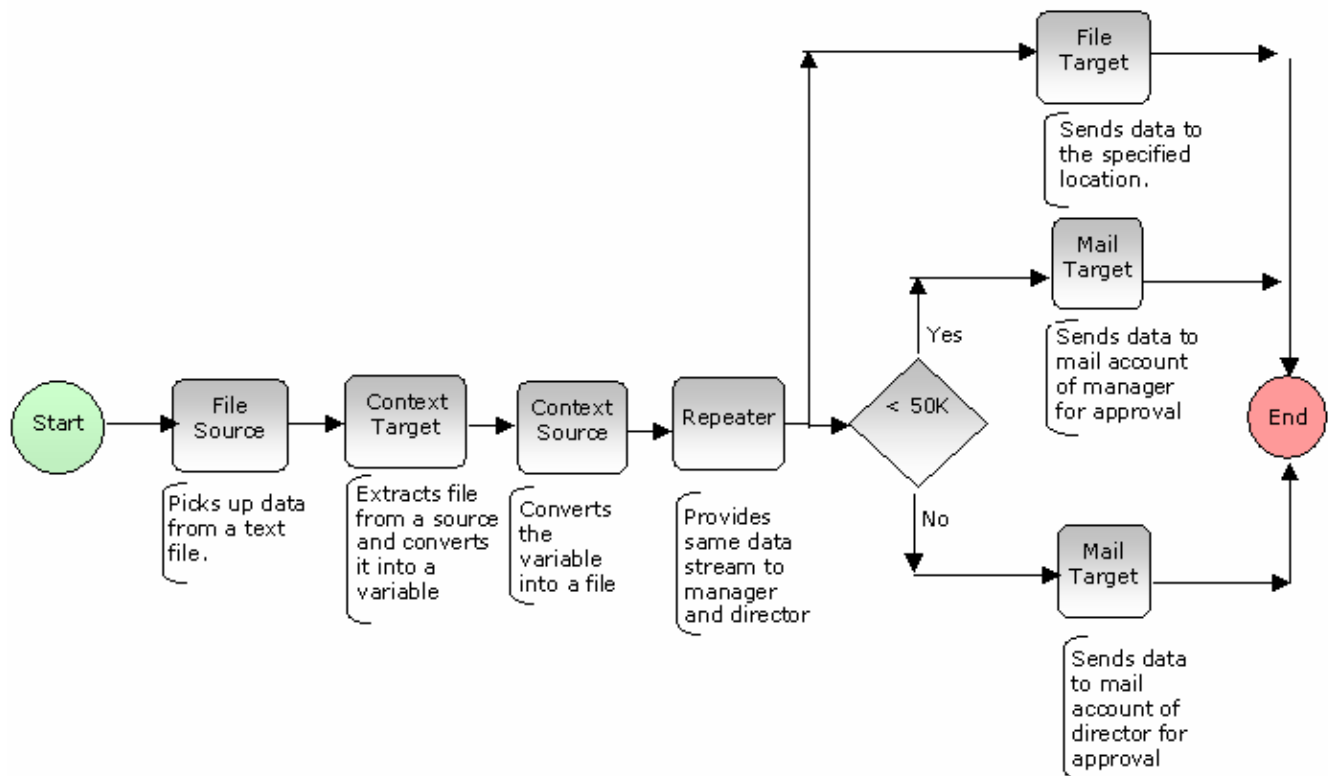

Figure 5.1: Flow Chart to show Process Flow

File Source (EvalPD_FileSource)

File Source activity is used to specify a file, which is stored in local drive, as source. File Source picks up the specified file and passes it to the other activity. In this Process Flow, a text file containing purchase order is specified as source.

Context Target

Context Target is used to put the data of the text file into the context of the Process Flow. From the context of the Process Flow, decision node picks up the amount and decides whether to send the data to Manager or to the Director.

Context Source

Context Source is used to take the data from the context of the Process Flow and to send it to the decision node.

Repeater

Repeater node is used to send the same stream to more than one activity. In this Process Flow repeater node is used to send stream, coming from Context Source, to the File Target activity and Mail Targets.

 Context Target, Context Source and Repeater Node are Process Designer features and you do not need to create any such activities.

File Target (EvalPD_FileTarget)

File Target is used to specify target Text file name with full path, where the target Text file is to be saved. In this Process Flow, file target is used to save a copy of the purchase order in the specified location for future use.

Mail Targets (EvalPD_MailTargetLessThan50k & EvalPD_MailTargetGreaterThan50k)

Mail Target is used to send the data to the specified email address. In this Process Flow two Mail Targets are used to send purchase order to either the manager or the director, for approval, depending upon value of purchase amount.

USAGE SCENARIO

This Process Flow can be used, whenever you want to process a purchase order based on the value of purchase amount.

DATA DESCRIPTION

Data used in this Process Flow is a purchase order in a text file format. This text file contains following information separated by comma (,).

The structure of Text File used as Source is displayed in the table below.

Table 5.1: Structure of Text File used as Source

Field Name	Description	Data Type
PO#	Purchase Order number	String
PO_AMOUNT	Purchase Amount	Number
COMPANY	Name of the company	String
ITEM	Name of the item to be purchased.	String

 The Target file also has the same fields as shown in Table 8.1.

PREREQUISITES

Mail Target activities must be edited before executing the Process Flow. These activities are outlined as:

- EvalPD_MailTargetLessThan50k
- EvalPD_MailTargetGreaterThan50k

 To know, how to edit these activities refer to section [Editing Activities](#).

EXECUTION AND MONITORING

This section describes the execution of sample Process Flow and monitoring Process Flow execution.

Steps to execute the Process Flow:

1. In the Adeptia Suite homepage menu, click **[+] Design** to expand the tree. All the items in the **Design** category are displayed.
2. Click **[+] Process Flow** to expand the tree and then click **Process Flow**. The Manage Process Flow screen is displayed with the list of existing Process Flows (refer to Figure 7.27).
3. Select the radio button adjacent to *EvalPD_ProcessFlow* Process Flow and then click **Execute** link. The View Process Flow Log screen is displayed (refer to Figure 3.2).
4. Click the link **Process Flow Logs** link to view the status of the Process Flow execution. The Process Flow Log is displayed (see Figure 5.2).

Reports > Process Flow Log										
Search Criteria										
Start Date	10/04/2007	Start Time	00 : 00	End Date	10/04/2007	End Time	23 : 59			
Process Flow Name	Select All	Sort By Name	Status	Executed	Details	Summary				
Activity Name	Activity Type	Status	UserID	Start Time	End Time	Action				
						<input type="radio"/> ERROR	<input checked="" type="radio"/> INFO	<input type="radio"/> DEBUG		
EvalPD_ProcessFlow	Transaction	Executed	admin	10/04/2007 17:59:30	10/04/2007 17:59:35	Details	Repository	Summary		
EvalPD_MailTargetGreaterThan50k	MailTarget	Executed	admin	10/04/2007 17:59:32	10/04/2007 17:59:35	Details	Repository	Summary		
EvalPD_FileTarget	FileTarget	Executed	admin	10/04/2007 17:59:32	10/04/2007 17:59:32	Details	Repository	Summary		
RepeaterService	RepeaterService	Executed	admin	10/04/2007 17:59:30	10/04/2007 17:59:31	Details	Repository	Summary		
DataSource	ContextSource	Executed	admin	10/04/2007 17:59:30	10/04/2007 17:59:30	Details	Repository	Summary		
Data	ContextTarget	Executed	admin	10/04/2007 17:59:30	10/04/2007 17:59:30	Details	Repository	Summary		
EvalPD_FileSource	FileSource	Executed	admin	10/04/2007 17:59:30	10/04/2007 17:59:30	Details	Repository	Summary		

Figure 5.2: View Searched Process Flows

 To view the summary of all instances of the process flow execution, click the **Summary** button.

- Click **Details** under the **Action** column of the activity of which you want to view execution details. This displays the Detailed Process Flow Activity Execution screen (see Figure 5.3).

Process Flow Log Details						
Process Flow Name : EvalPD_ProcessFlow Process Flow PID : 192168001007119150096999301222						
Date/Time	Activity Name	Activity Type	Status	Message	Level	Location
10/04/2007 17:59:35	EvalPD_ProcessFlow	Transaction	Executed	Activity disposed. Start Time:2007-10-04 17:59:30 End Time:2007-10-04 17:59:35 Run Time:5 second(s) 288 ms	INFO	services.AbstractService.dispose(AbstractService.java:237
10/04/2007 17:59:35	EvalPD_ProcessFlow	Transaction	Running	Context Information: {TransactionAddress=localhost://indigo.Transaction[192168001006115571166220300005!192168001007119150096999301222,type=Transaction,name=EvalPD_ProcessFlow,id=192168001006115571166220300005,pid=192168001007119150096999301222, PO_Amount=50001, currentState=state-BPMN:TASK:BASIC_TASK-974335, Data=PO##PN33596,PO_AMOUNT=50001,COMPANY=ABC CO. LTD,ITEM=Crane, LoggingLevel=INFO, PO##PN33596}	INFO	services.AbstractService.dispose(AbstractService.java:178
10/04/2007 17:59:35	EvalPD_MailTargetGreaterThan50k	MailTarget	Executed	Activity disposed. Start Time:2007-10-04 17:59:32 End Time:2007-10-04 17:59:35 Run Time:3 second(s) 205 ms	INFO	services.AbstractService.dispose(AbstractService.java:237
10/04/2007 17:59:32	EvalPD_MailTargetGreaterThan50k	MailTarget	Running	Execute	INFO	services.AbstractService.execute(AbstractService.java:457
10/04/2007 17:59:32	EvalPD_MailTargetGreaterThan50k	MailTarget	Running	Initialize	INFO	services.AbstractService.initialize(AbstractService.java:1
10/04/2007 17:59:32	EvalPD_FileTarget	FileTarget	Executed	Activity disposed. Start Time:2007-10-04 17:59:32 End Time:2007-10-04 17:59:32 Run Time:50 ms. Operation count:59 Bytes Average:1180.0 operations/sec	INFO	services.AbstractService.dispose(AbstractService.java:237
10/04/2007 17:59:32	EvalPD_FileTarget	FileTarget	Running	Execute	INFO	services.AbstractService.execute(AbstractService.java:457
10/04/2007 17:59:32	EvalPD_FileTarget	FileTarget	Running	Initialize	INFO	services.AbstractService.initialize(AbstractService.java:1
10/04/2007 17:59:31	RepeaterService	RepeaterService	Executed	Activity disposed. Start Time:2007-10-04 17:59:30 End Time:2007-10-04 17:59:31 Run Time:1 second(s) 31 ms. Operation count:59 Bytes Average:57.225994 operations/sec	INFO	services.AbstractService.dispose(AbstractService.java:237
10/04/2007 17:59:30	RepeaterService	RepeaterService	Running	Execute	INFO	services.AbstractService.execute(AbstractService.java:457
10/04/2007 17:59:30	RepeaterService	RepeaterService	Running	Initialize	INFO	services.AbstractService.initialize(AbstractService.java:1

Close Window

Figure 5.3: View Process Flow Log Details

EDITING ACTIVITIES

Activities used in this sample Process Flow are pre-created. This section describes how to edit these activities.

File Source

(EvalPD_FileSource)

File Source activity is used to specify a file, which is stored in local drive, as source. File Source picks up the specified file and passes it to the other activity. In this Process Flow a text file (**EvalPD_FileSource.txt**) is specified as source. This file is stored in **../..../Solutions/Demo/EvalPD/** directory.

Steps to edit the File Source:

- In the Adeptia Suite homepage menu, click **[+] Configure** to expand the tree. All the items in the **Configure** category are displayed.
- Click **[+] Services** to expand the tree. All the items in the **Services** category are displayed.

3. Click **[+] Source** to expand the tree, and then click **File**. The Manage File Source screen is displayed with the list of existing File Source activities (refer to Figure 4.4).
4. Select the radio button adjacent to *EvalPD_FileSource* activity and then click **Edit** link. This displays the Edit *EvalPD_FileSource* activity screen, with the properties of the activity displayed in their respective fields (see Figure 5.4).

Configure > Services > Source > File > EvalPD_FileSource

[−] Standard properties

Name *	<input type="text" value="EvalPD_FileSource"/>
Description *	<input type="text" value="file source containing purchase order"/>
File Path *	<input type="text" value=".\Solutions\Demo\EvalPD"/>
File Name *	<input type="text" value="EvalPD_FileSource.txt"/>

[+] Advanced properties

* Mandatory fields.

Save
Save As
Cancel
Test

Figure 5.4: Edit *EvalPD_FileSource* Activity

A detailed description of fields on this screen is explicated in the table below.

Table 5.2: Details of Fields on Edit File Source Screen

Field Name	Field Description
Name	Name of the File Source
Description	Description of the File Source
File Path	Path of the source file. For example: ../../Solutions/Demo/EvalPD/
File Name	Name of the source file. For example : EvalPD_FileSource.txt

5. Make the necessary changes.
6. Once you have made the required changes, click the **Save** button to save the changes. A screen is displayed confirming that the File Source Activity has been updated successfully. If the *comments* property is enabled, then clicking **Save** will display a screen where you need to enter comments related to updating the file source activity (refer to Figure 7.10).
7. Enter the comments in the *Add Comments* field.

The comment should be at least 1 character in length.

- Click **OK** to save the comments. This displays a screen confirming that the file source activity has been updated successfully.

	<p>You can verify the file source activity at design time. For this, click Test Connection. This verifies the values in the <i>File Path</i> and <i>Filename</i> fields and checks whether the file actually exists in the specified location.</p>
---	---

Editing File Target (EvalPD_FileTarget)

File target is used to specify the name of the target file and path, where the target file is saved. In this sample Process Flow, target file is saved in `../../Solutions/Demo/EvalPD/EvalPD_FileTarget.txt` directory.

Steps to edit the File Target:

- In the Adeptia Suite homepage menu, click **[+] Configure** to expand the tree. All the items in the **Configure** category are displayed.
- Click **[+] Services** to expand the tree. All the items in the **Services** category are displayed.
- Click **[+] Target** to expand the tree, and then click **File**. The Manage File Target screen is displayed with the list of existing File Target activities (refer to Figure 3.17).
- Select the radio button adjacent to *EvalPD_FileTarget* activity and then click **Edit** link. This displays the Edit *EvalPD_FileTarget* activity screen, with the properties of the activity displayed in their respective fields (see Figure 5.5).



Configure > Services > Target > File > EvalPD_FileTarget

[-] Standard properties

Name *	EvalPD_FileTarget
Description *	file target with purchase order
File Path *	..\Solutions\Demo\EvalPD
File Name *	EvalPD_FileTarget.txt

[+] Advanced properties

* Mandatory fields.

Save Save As Cancel Test

Figure 5.5: Edit *EvalPD_FileTarget* Activity

A detailed description of fields on this screen is explicated in the table below.

Table 5.3: Details of Fields on Edit File Target Screen

Field Name	Field Description
Name	Name of the File Target
Description	Description of the File Target
File Path	Path of the target file. For example: <code>../../../../Solutions/Demo/EvalPD/</code>
File Name	Name of the target file. For example: <code>EvalPD_FileTarget.txt</code>

5. Make the necessary changes.
6. Once you have made the required changes, click the **Save** button to save the changes. A screen is displayed confirming that the File Target Activity has been updated successfully. If the *comments* property is enabled, then clicking **Save** will display a screen where you need to enter comments related to updating the file target activity (refer to Figure 7.10).
7. Enter the comments in the *Add Comments* field.

	The comment should be at least 1 character in length.
---	---

8. Click **OK** to save the comments. This displays a screen confirming that the file target activity has been updated successfully.

	You can verify the file target activity at design time. For this, click Test Connection . This verifies the values in the <i>File Path</i> and <i>Filename</i> fields and checks whether the file actually exists in the specified location.
---	---

Editing Mail Target

(EvalPD_MailTargetLessThan50K

&

EvalPD_MailTargetGreaterThan50K)

Mail Target provides the ability to specify target location that is accessible via Mail. In this Process Flow, mail target is used to send target data either to the manager or the director depending on whether the given condition is true or false. When the purchase amount is less than US\$ 50000, EvalPD_MailTargetLessThan50K is executed and mail is sent to the Manager for approval. When the purchase amount is greater than US\$ 50000, EvalPD_MailTargetGreaterThan50K is executed and mail is sent to the Director for approval.

Steps to edit the Mail Target:

1. In the Adeptia Suite homepage menu, click **[+] Configure** to expand the tree. All the items in the **Configure** category are displayed.

2. Click **[+] Services** to expand the tree. All the items in the **Services** category are displayed.
3. Click **[+] Target** to expand the tree, and then click **Mail**. The Manage Mail Target screen is displayed with a list of existing Mail Target activities (see Figure 5.6).

Configure > Services > Target > Mail					
New Edit Delete Revisions Dependencies					
--Select Field to Search--					Search
#	Name	Description	Owner	Perm.	Modified
1	<input type="radio"/> SendCustomerOrders	this email sends updated file with shipping and invoice info	demouser	RWX	09/01/09 12:27
2	<input type="radio"/> NotifySales	notify sales if quantity exceeds 100	demouser	RWX	09/01/09 12:26
3	<input type="radio"/> EvalPD_MailTargetLessThan50k	mail target for purchase order less than \$50,000	demouser	RWX	08/23/05 15:02
4	<input type="radio"/> EvalPD_MailTargetGreaterThan50k	mail target for approved purchase order	demouser	RWX	08/12/05 15:21

Figure 5.6: Manage Mail Target

4. Select the radio button adjacent to *EvalPD_MailTargetLessThan50K* activity and then click **Edit** link. This displays the Edit *EvalPD_MailTargetLessThan50K* activity screen, with the properties of the activity displayed in their respective fields (see Figure 5.7).

Configure > Services > Target > Mail > EvalPD_MailTargetLessThan50k

[-] Standard properties

Name *	<input type="text" value="EvalPD_MailTargetLessThan50k"/>
Description *	<input type="text" value="mail target for purchase order less th"/>
Protocol *	<input type="text" value="SMTP"/>
Outgoing Mail Server *	<input type="text" value="SMTPServerName"/>
Domain	<input type="text"/>
CDO host machine	<input type="text"/>
Enable SSL	<input type="checkbox"/>
Port	<input type="text" value="25"/>
From(Email-Id) *	<input type="text" value="SenderEmail@CompanyName.com"/>
To Email-Id(s) (comma separated) *	<input type="text" value="ReceipentEmail@CompanyName.co"/>
Subject *	<input type="text" value="Purchase order less than \$50,000"/>
User Id	<input type="text" value="UserName"/>
Password	<input type="text"/>
Confirm Password	<input type="text"/>
Message Content Type	<input type="text" value="Plain"/>
Data Location*	<input type="text" value="Attachment"/>
File Name	<input type="text" value="purchaseorder.txt"/>

[+] Advanced properties

* Mandatory fields.

Save Save As Cancel Test

Figure 5.7: Edit *EvalPD_MailTargetLessThan50K* Activity

A detailed description of fields on this screen is explicated in the table below.

Table 5.4: Details of Fields on Edit Mail Target Screen

Field Name	Field Description
Name	Name of the Mail Target.
Description	Description of the Mail Target.
Outgoing Mail(SMTP)	Name or IP address of the Outgoing Mail or SMTP Server.

Server	
From(Email-Id)	Sender's email address
To Email-Id(s) (comma separated)	Email Id(s) of the recipient(s) separated by commas
Subject	Subject of target email
User ID	Username required to access the mailbox
Password	Password required to access the mailbox
Confirm Password	Re-enter the password for confirmation
Data Location	Data Location specifies whether the data is in the email body or is contained in an attached file.
File Name	Name of the file that is used as an attachment

5. Make the necessary changes.
6. Once you have made the required changes, click the **Save** button to save the changes. A screen is displayed confirming that the Mail Target Activity has been updated successfully. If the *comments* property is enabled, then clicking **Save** will display a screen where you need to enter comments related to updating the mail target activity (refer to Figure 7.10).
7. Enter the comments in the *Add Comments* field.

 The comment should be at least 1 character in length.

8. Click **OK** to save the comments. This displays a screen confirming that the mail target activity has been updated successfully.

 You can verify the mail target activity at design time. For this, click **Test Connection**.

 Repeat the same steps to edit the *EvalPD_MailTargetGreaterThan50K* activity.

CREATING PROCESS FLOW



(EvalPD_ProcessFlow)

Process Flow is the set of activities arranged in a sequence to perform a specific task(s). Process Flow is created by combining various activities such as Source, Target, Schema or Transformer activities in a logical sequence. Process Designer is used to create a Process Flow. Process Designer has list of activities created. You only need to arrange them in a logical sequence and connect them with BPMN Flows.

Steps to create EvalPD_ProcessFlow:

1. In the Adeptia Suite homepage menu, click **[+] Design** to expand the tree. All the items in the **Design** category are displayed.

2. Click **[+] Process Flow** to expand the tree and then click **Process Flow**. The Manage Process Flow screen is displayed with the list of existing Process Flows (refer to Figure 7.27).
3. Click the **New Process Flow** button. The Create Process Flow screen is displayed (refer to Figure 7.28).
4. Enter the name and the description of the new Process Flow in the *Name* and *Description* box respectively.
5. Select the logging level from the *Logging Level* drop-down list. There are four level of logging. They are described in Table 7.9.
6. Select repository file retention from the *Repository File Retention* option. During execution Process Flow creates a temporary repository file to store the intermediate data. These repository files can cause unnecessary disk space usage and you may want to delete them after execution of the Process Flow. On the other hand sometime these repository files can be helpful in case of failure of Process Flow execution. For each instance of the Process Flow execution a unique repository folder is created that contains Source, intermediate XML data files and target formatted data. By default repository files are being stored in the repository folder of the Adeptia Suite. You can also choose an option to delete them or to archive them in a different location. There are four options for the Repository File Retention. They are described in Table 7.10.
7. Click the **Process Designer** button to open Process Designer. The Process Designer Screen is displayed (refer to Figure 7.29).
8. Once the Process Designer screen is displayed, a message to synchronize the list of activities and Process Flow with the Adeptia Suite is displayed. Click **OK** to synchronize.

	Alternately, you can synchronize the list of activities and Process Flow with the Adeptia Suite by clicking the Synchronize () button displayed on the Tool Bar.
---	--

9. Click **[+] Activities** in Repository Panel, to expand the list of services and then click **[+] Source**. All the items in the **Source** category are displayed.
10. Click the **[+] File Source**. A list of existing File Source activities that is displayed.
11. Select **EvalPD_FileSource** and drag it to the Graph Canvas Area (see Figure 5.8).

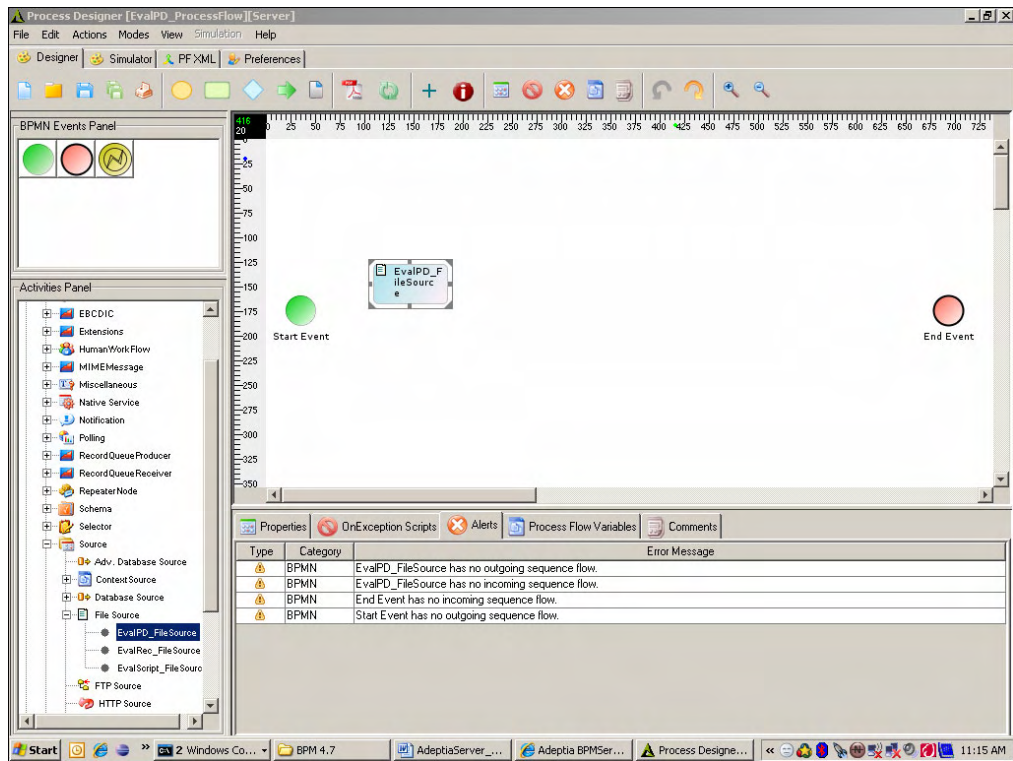

Figure 5.8: Drag File Source Activity to Graph Canvas Area

12. To create Process Flow Variable, click *Process Flow Variables* tab in the bottom pane. The Process Flow Variables panel is displayed in bottom pane. (see Figure 5.9)

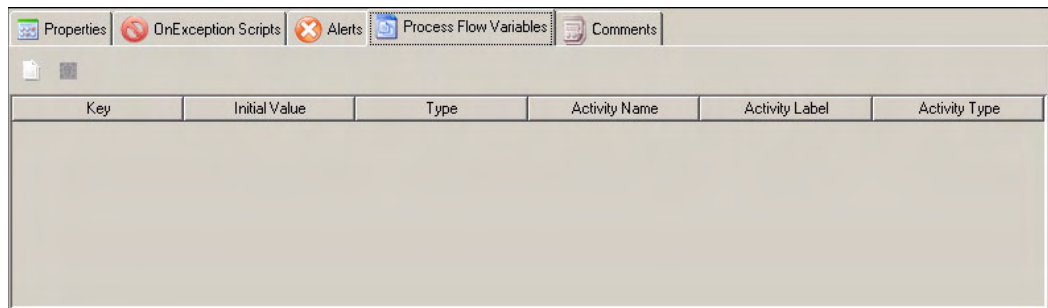



Figure 5.9: Process Flow Variables Panel

13. Click **New Process Flow Variable** () button. The Process flow variable entry dialog box is displayed (see Figure 5.10).

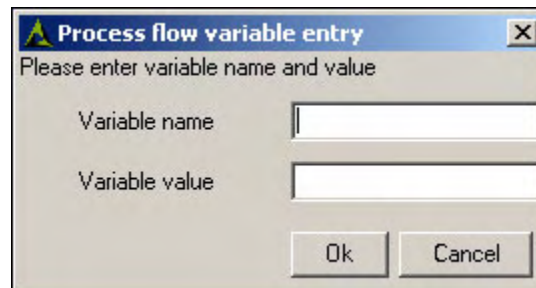

Figure 5.10: Create Process Flow Variable

14. Enter *Data* in the *Variable Name* field and click **OK**. A process flow variable with name *Data* is created.
15. To create Context Target, click **[+] Target** under Activities list in Repository View, to expand the list of Target activities.
16. Click **[+] Context Target** activity to expand the Context Target activity. The Context Target node is displayed.
17. Drag the Context Target node to the Graph Canvas Area (see Figure 5.11).

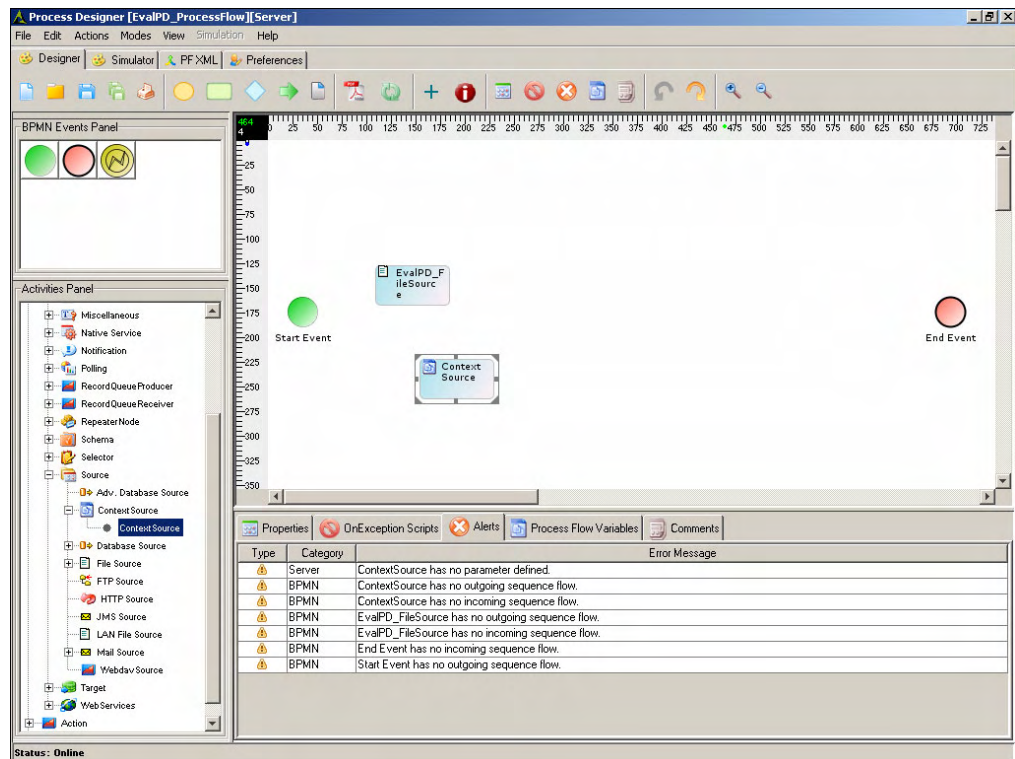

Figure 5.11: Drag Context Source Activity to Graph Canvas Area

18. Right-click the Context Target and select **View Properties**. Properties of the Context Target are displayed in the Bottom Pane (see Figure 5.12).

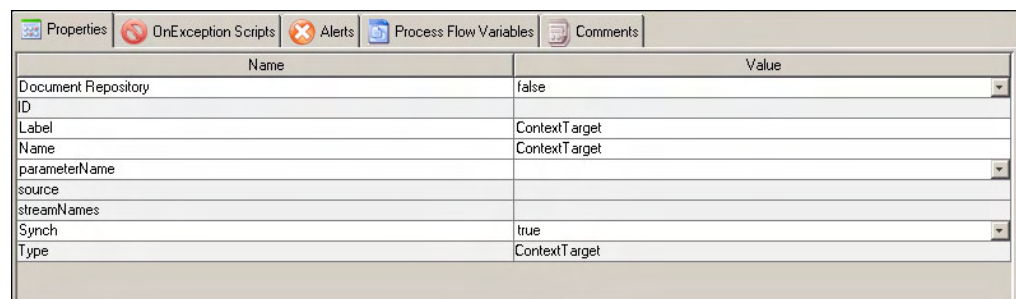
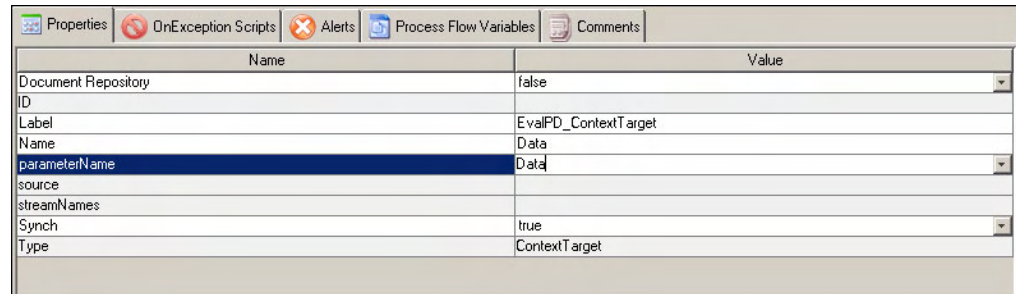

Figure 5.12: View Properties of Context Target Activity

19. Enter the name of the context Target as *Data* in the *Value* field of the *Name* property

20. Change the value of *Label* from *Context Target* to *EvalPD_ContextTarget*.
21. Select *Data* from the *parameterName* drop-down list (see Figure 5.13).



Name	Value
Document Repository	false
ID	
Label	EvalPD_ContextTarget
Name	Data
parameterName	Data
source	
streamNames	
Synch	true
Type	ContextTarget

Figure 5.13: Enter Context Target Name

22. Click **[+] Source** and then **[+] Context Source**. Select **Context Source** and drag it to Graph Canvas Area.
23. Right-click the Context Source and select **View Properties**. Properties of the Context Source are displayed in the Bottom Pane (see Figure 5.14).

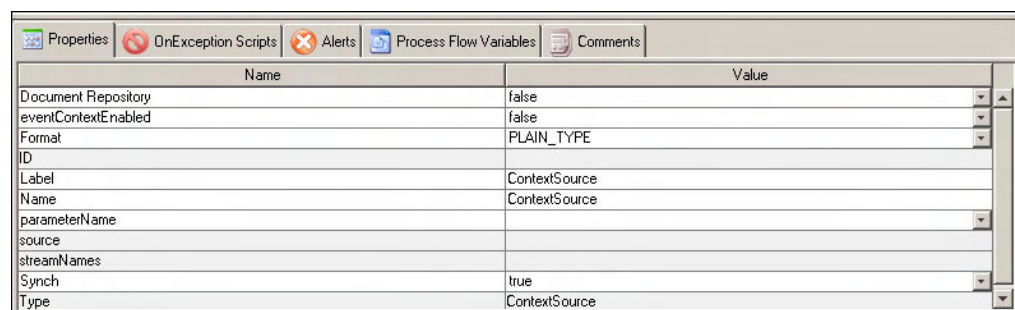

Name	Value
Document Repository	false
eventContextEnabled	false
Format	PLAIN_TYPE
ID	
Label	ContextSource
Name	ContextSource
parameterName	
source	
streamNames	
Synch	true
Type	ContextSource

Figure 5.14: View Properties of Context Source activity

24. Enter the name of the context Target as *DataSource* in the *Value* field of the *Name* property
25. Change the value of *Label* from *Context Source* to *EvalPD_ContextSource*.
26. Select *Data* from the *parameterName* drop-down list (see Figure 5.15).

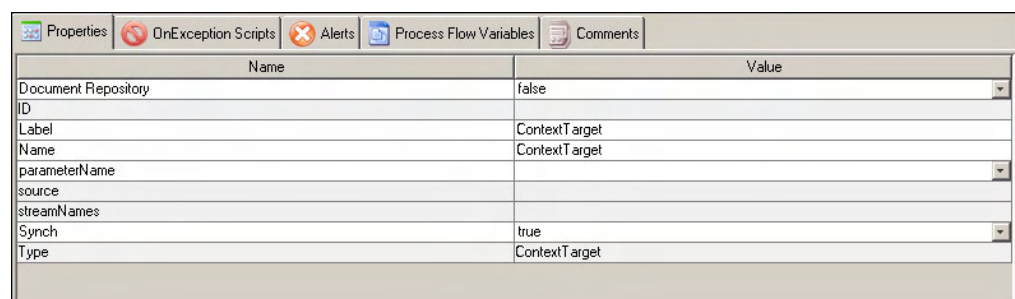

Name	Value
Document Repository	false
ID	
Label	ContextTarget
Name	ContextTarget
parameterName	Data
source	
streamNames	
Synch	true
Type	ContextTarget

Figure 5.15: Enter Context Source Name

27. Click **[+] Repeater Node** to expand it. Select **Repeater Service** and drag it to the Graph Canvas Area.
28. Click **[+] Target** and then **[+] File Target**. Select **EvalPD_FileTarget** activity and drag it to the Graph Canvas Area.



29. To select a BPMN Gateway, click the **Gateway** () icon in the Palette and drag it to the Graph Canvas Area (see Figure 5.16). In this Process Flow, **Gateway** is used to check the purchase amount and to decide which mail target is to be used.



Figure 5.16: Drag BPMN Gateway Element to Graph Canvas Area

30. Click [+]**Action** to expand the list of actions.

	An Action name is always unique.
---	----------------------------------

31. Select **Trace** and drag it to the Graph Canvas Area. *Trace* is used to write any message, which is later, logged into the Process Flow Log during the execution of Process Flow (see Figure 5.17).

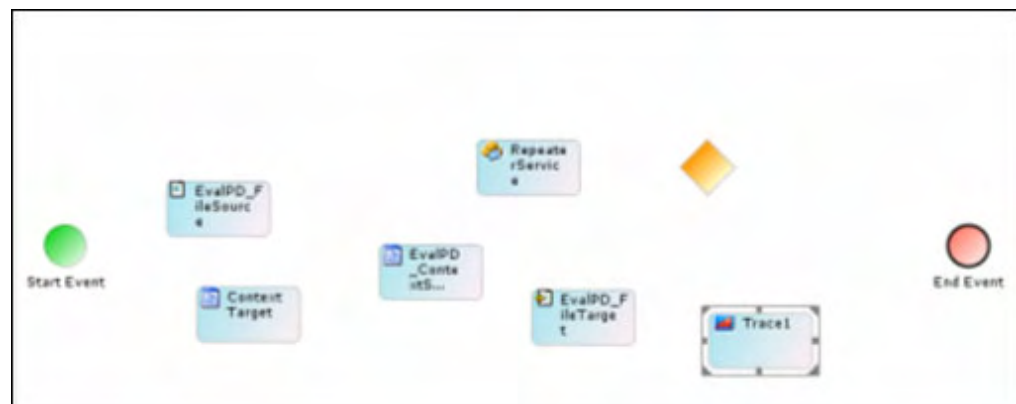

Figure 5.17: Drag Trace Action

32. To enter the message, right-click the **Trace** activity and select **View Properties**. The properties of the trace activity are shown in the Properties Panel of the Bottom Pane (see Figure 5.18).

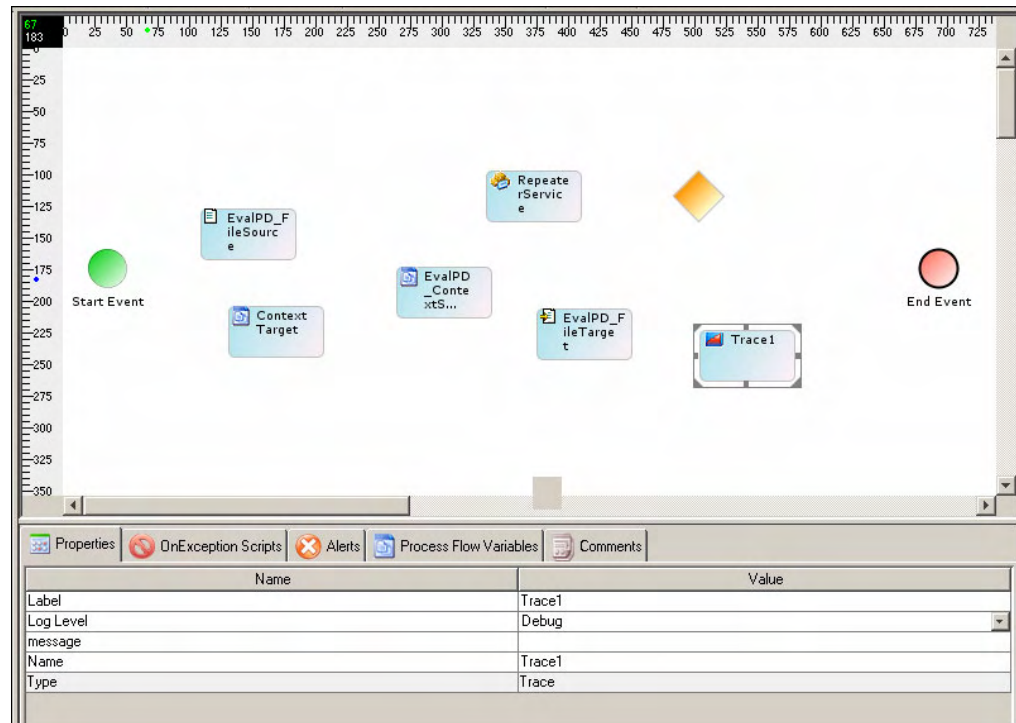

Figure 5.18: View Properties of Trace Action

33. In the value field of the *Message* property enter the following message:

*Mailing Purchase Order (PO# = \$\$PO#\$\$ and Amount = \$
\$\$PO_Amount\$\$) for approval to Manager*

34. Change the Name and Label of the *Trace* activity to *EvalPD_TraceForPOLessThan50K*.
35. Similarly, again drag **Trace** from the list of actions, change its Name and Label to *EvalPD_TraceForPOGreaterThen50K* and enter the following message in the *Value* field of the Message property (see Figure 5.19).

*Mailing Purchase Order (PO# = \$\$PO#\$\$ and Amount = \$
\$\$PO_Amount\$\$) for approval to Director*

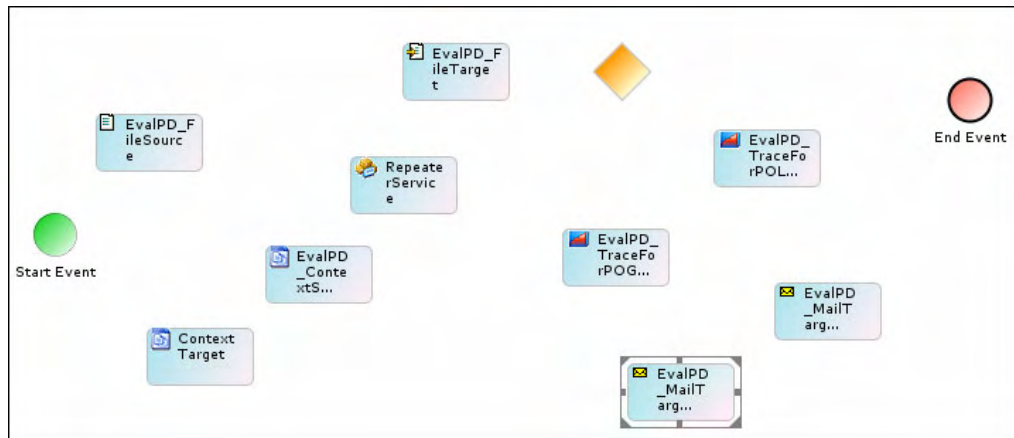

Figure 5.19: Drag another Trace Action

36. Click **[+] Target** and then **[+] Mail Target**. Select **EvalPD_MailTargetLessThan50K** activity and drag it to the Graph Canvas Area.
37. Select **EvalPD_MailTargetGreaterThan50K** activity and drag it to the Graph Canvas Area.
38. Once all the activities are dragged to the Graph Canvas Area, they must be connected using appropriate BPMN Flows or Control Flows.
39. Click the **Sequence Flow** (→) icon in the Palette. The Sequence flow is selected.
40. To connect *Start Event* with *EvalPD_FileSource*, drag mouse pointer from *Start Event* to *EvalPD_FileSource* (see Figure 5.20).

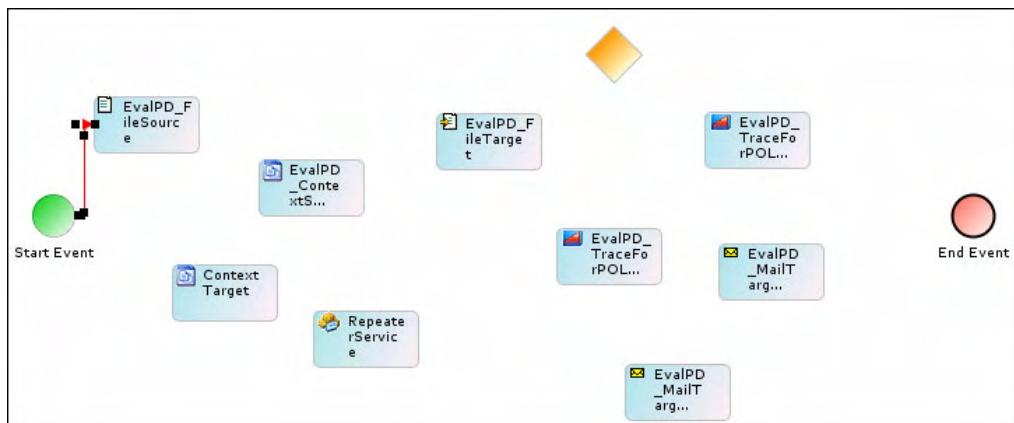

Figure 5.20: Connect Start Event to File Source Activity

41. Similarly, connect all other activities as shown in Figure 5.21.

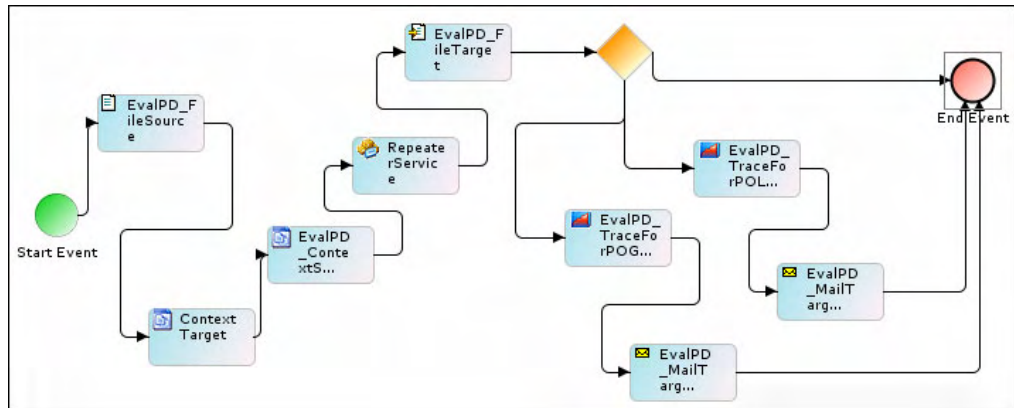



Figure 5.21: Connect all Activities

	<p>Figure 5.21 shows only the control flow of the Process Flow. Control Flow only shows the order in which activities of a Process Flow are executed. It does not show the flow of data. For example as you can see in the Figure 5.21, control flow from Repeater Service goes to EvalPD_FileTarget and further to the Decision Node. But data is not passed from EvalPD_FileTarget to the Decision Node. Data is directly passed from Repeater Service EvalPD_FileTarget and both of the mail target activities (EvalPD_MailTargetLessThan50k and EvalPD_MailTargetGreaterThan50k). To create the data flow, you need to create Multiple Stream from repeater service to EvalPD_FileTarget and Mail Target activities. Here you need to create two streams from the Repeater Service. One Stream goes to EvalPD_FileTarget and the other stream goes to both of the Mail Target activities.</p>
---	---

42. To create data stream, right-click **Repeater Service** and select **Multiple Stream**. The Multiple Stream dialog box is displayed (refer to Figure 4.22).
43. Enter number of streams (2) in the *Enter stream count* field, and then click the **Add Stream** button.
44. Select *1* from the *Streams* drop-down list, and select **EvalPD_FileTarget**. from the *Activities* drop-down list,
45. Click the **Map** button. A stream between *Repeater Service* and *EvalPD_FileTarget* is created (see Figure 5.22).

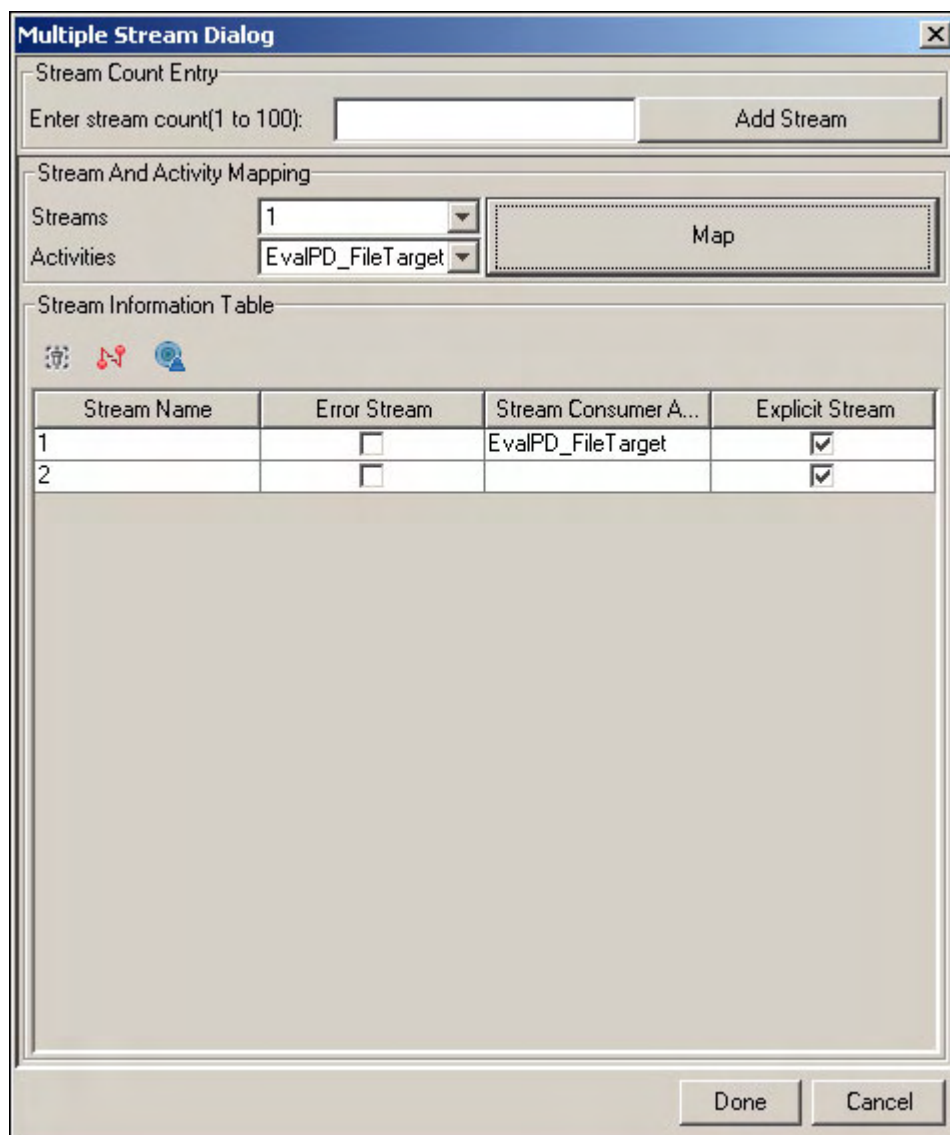

Figure 5.22: Create Stream

46. Ensure that the *Explicit Stream* checkbox is checked.
47. Select **2** from the *Streams* drop-down list, and select **EvalPD_MailTargetLessThan50K** from the *Activities* drop-down list, and click the **Map** button.
48. Select **EvalPD_MailTargetGreaterThan50K** from *Activities* drop-down list, and click the **Map** button. A dialog box is displayed (see Figure 5.23).

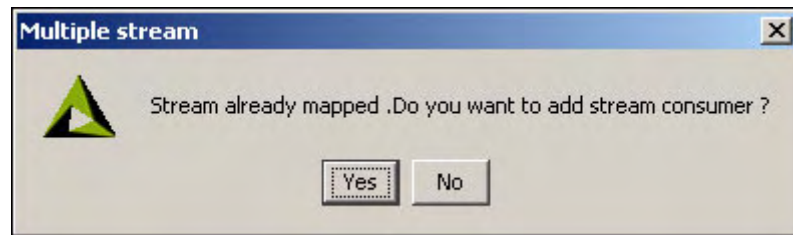

Figure 5.23: Add another Stream

49. Click the **Yes** button to add second mail target activity to the same stream.
50. Click the **Done** button to close the Multiple Stream Dialog box. Data stream created is shown in the Graph Canvas area (see Figure 5.24).

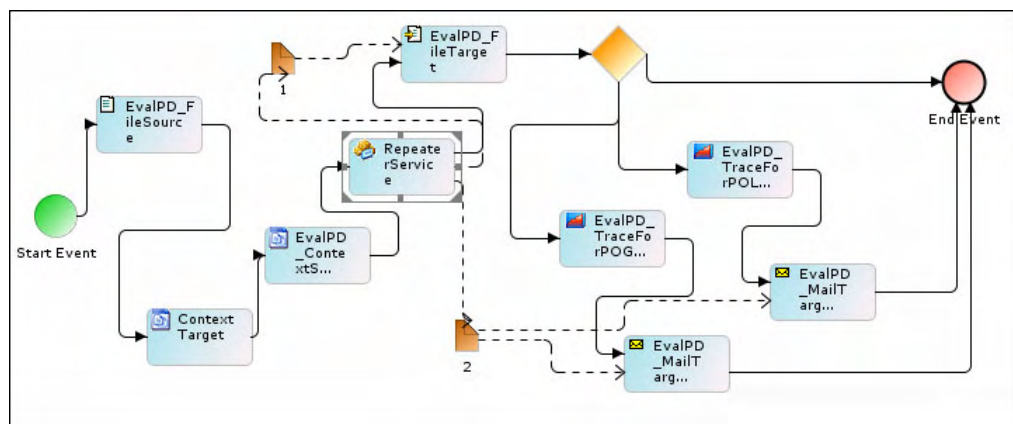

Figure 5.24: Multiple Streams Created

51. To define the decision criteria, right-click the control flow which is connecting Decision Node with *EvalPD_TraceForPOLessThan50K* and select **View Properties**. Properties of the selected control flow are shown in the Properties Panel in the Bottom Pane.
52. Click the **Edit Condition** in the Properties Panel. The Condition Wizard is displayed (refer to Figure 8.30).
53. Select **Java Condition** and click the **Next** button. The Condition Type screen is displayed (refer to Figure 8.31).
54. Enter the sample Java Code to specify the decision criteria and click the **Done** button (see Figure 5.25).

```

// retrieving purchase order from context
String purchaseOrderData = (String) context.get("Data");
// filling purchase order attributes
String [] dataArray = purchaseOrderData.split(",");
int amount = 0;
for( int i = 0 ; i < dataArray.length ; i++ )
{
//extracting purchase order PO_AMOUNT attribute
    if( dataArray[i].indexOf("PO_AMOUNT")!= -1)
    {
        String [] attributeArray = dataArray[i].split("=");
        context.put("PO_Amount", attributeArray[1] );
    }
}

```

```

        amount = Integer.parseInt(attributeArray[1]);
    }else if( dataArray[i].indexOf("PO#")!= -1)
    {
//extracting purchase order PO# attribute
        String [] attributeArray = dataArray[i].split("=");
        context.put("PO#", attributeArray[1] );
    }
}
// checking condition
if(amount < 50000){
    return true ;
}else{
    return false;
}

```

Figure 5.25: Sample JAVA Code

55. Similarly, define the following decision criteria on the Control Flow connecting decision node and *EvalPD_TraceForPOGreaterThen50K*. (see Figure 5.26).

```

// retrieving purchase order from context
String purchaseOrderData = (String) context.get("Data");
//splitting order to fill attributes
String [] dataArray = purchaseOrderData.split(",");
int amount = 0;
for( int i = 0 ; i < dataArray.length ; i++ )
{
    //filling amount from PO_AMOUNT attribute
    if( dataArray[i].indexOf("PO_AMOUNT")!= -1){
        String [] attributeArray = dataArray[i].split("=");
        amount = Integer.parseInt(attributeArray[1]);
    }
}
if(amount >= 50000)
return true ;

```

Figure 5.26: Define Decision Criteria

56. To define the Sequence Flow Ordering, right-click the **decision** node and select the **Sequence Flow Ordering** option. The Sequence Flow Ordering dialog box appears (refer to Figure 8.33).
57. Ensure that the control flow connecting decision node and the **EvalPD_TraceForPOLessThan50K** is listed first.



A default outgoing sequence flow is added for the gateway. While executing a process flow, if none of the specified conditions are met, then the default gateway is executed. If there is no default gateway specified, then an error occurs at the Process Flow design level.

58. Save the Process Flow by clicking the **File** menu and selecting **Save Process Flow to Server**. A dialog box is displayed confirming that the *EvalPD_ProcessFlow* has been saved successfully. If the *comments* property is enabled, then clicking **Save Process Flow to Server** will display a screen where you need to enter comments related to creating the process flow (refer to Figure 7.37).
59. Enter the comments in the *Specify Comments for process flow customer* field.



The comment should be at least 1 character in length.

60. Click **OK** to save the comments. This displays a screen confirming that the process flow has been created successfully.
61. Exit the Process Designer by clicking the **File** menu and selecting **Exit**.

6 PROCESS FLOW TO PROCESS EXCEL DATA

This section describes the sample Process Flow, which is used to process contents of an Excel file attached with an email.

In the Adeptia Suite this process flow is available in:

BPM Suite	Workflow Suite	Integration Suite	ETL Suite
√		√	√

INTRODUCTION

This sample Process Flow demonstrates the use of different features of process designer and complex mapping functions. The Process Flow is triggered on arrival of emails with different subject. Each mail has an excel file attached to it. Subject of the mail specifies the format of the excel file. Based on subject of the mail, Decision Node of the Process Flow decides which schema to be used to parse data of the Excel file. For example, if subject of email is FORMAT1, Schema1 is used. If subject of email is FORMAT2, schema2 is used. After the data is parsed using either of the schemas, mapping rules are applied and data is inserted or updated into one of the two databases. All error records (e.g. duplicate record) are written into a sequential file.

SERVICES USED IN THIS SAMPLE PROCESS FLOW

This sample Process Flow illustrates the use of following services of Adeptia Suite:

- Mail Event to trigger the Process Flow on arrival of a mail
- Mail Source to receive data from mail event and forward it to Excel Schema
- Excel Schema to convert data of excel file into intermediate XML format
- Mapping to map data fields of Excel schema and Database Schema
- Database Schema to convert data from intermediate XML format to database specific format
- Database Target to insert or update data into the database server
- Process Designer to create Process Flow. Following Process Designer features are used in this Process Flow:
 - Decision Node to decide which excel schema to use based on incoming Excel file format
 - Multiple Streams to send data from one source to more than one schema
 - Put context Var to append date and time stamp with the name of the file at the target end

DESCRIPTION

This sample Process Flow can be outlined as below:

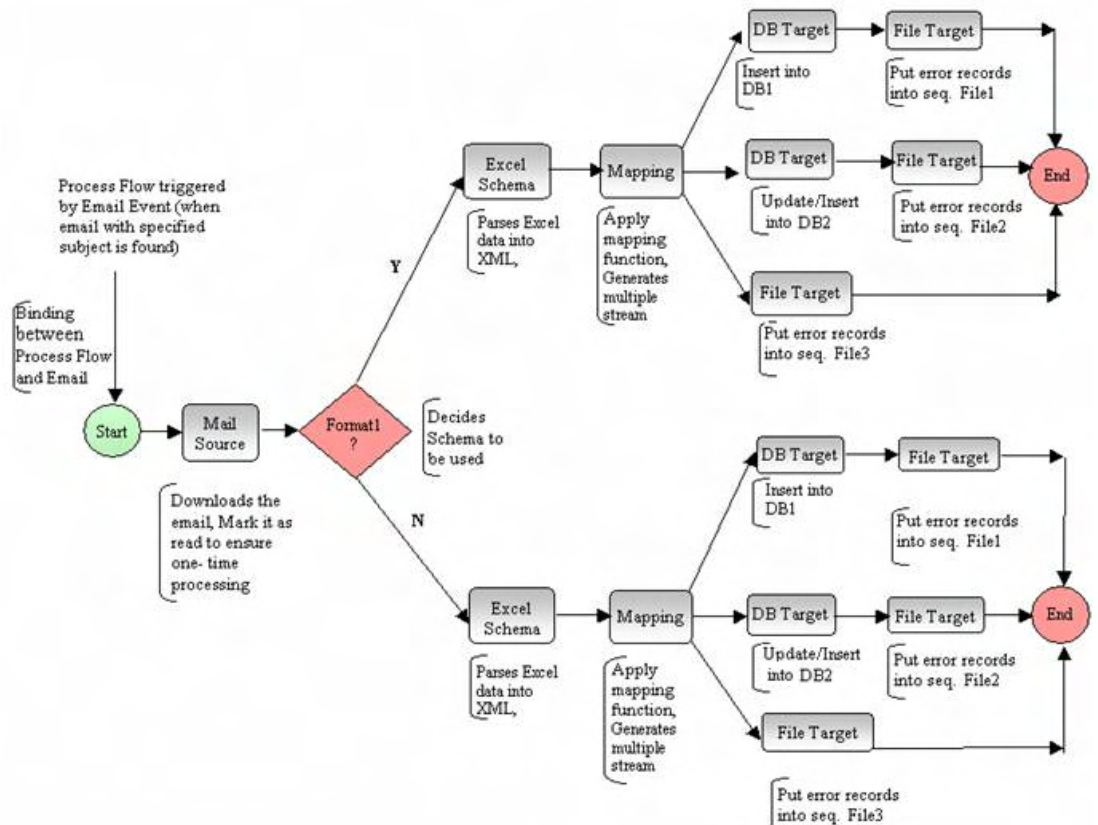

Figure 6.1: Flow Chart of the Process Flow

Mail Event (EvalPF_MailEvent_Format1 and EvalPF_MailEvent_Format2)

Mail Event is used to trigger Process Flow when a message from specified sender or with specified subject arrives in a mailbox. In this Process Flow two Mail Events are used. The Mail Event **EvalPF_MailEvent_Format1** is used to trigger the Process Flow when a message with subject **Format1** arrives in the mailbox. The Mail Event **EvalPF_MailEvent_Format2** is used to trigger the Process Flow when a message with subject **Format2** arrives in the mailbox.

Event Registry (EvalPF_EventRegistry_Format1 and EvalPF_EventRegistry_Format2)

Event Registry is used to register the Mail Events with Process Flow. In other words Event Registry is a link between Mail Event and the Process Flow. EvalPF_EventRegistry_Format1 is used to register EvalPF_MailEvent_Format1 with

the Process Flow. EvalPF_EventRegistry_Format2 is used to register EvalPF_MailEvent_Format2 with the Process Flow.

Process Flow (EvalPF_ProcessFlow)

Process Flow receives data from one of the Mail events, converts it into database format and then inserts the data in one of the two databases. Process Flow does this conversion using following sequence of activities:

1. Mail Source (EvalPF_MailSource)

Mail source is used to receive data from Mail Events and forward it to one of the two Excel schemas based on subject of the mail.

2. Excel Schema (EvalPF_ExcelSchema_Format1 and EvalPF_ExcelSchema_Format2)

Excel Schema is used to parse the data from the excel file attached with mail received from Mail Source. Excel Schema converts the parsed data into intermediate XML format. If subject of mail is Format1, EvalPF_ExcelSchema_Format1 is used to parse the data. If subject of mail is Format2, EvalPF_ExcelSchema_Format2 is used to parse the data.

3. Mapping (EvalPF_MappingTransformation_Format1 and EvalPF_MappingTransformation_Format2)

Mapping is used to map data fields of Excel schema with data fields of Database Schema. Similar to Excel Schema, two different mapping activities are used based on subject of the mail.

4. Database Schema (EvalPF_DatabaseSchema_Database1 and EvalPF_DatabaseSchema_Database2)

At the target end, database Schema is used to convert data from intermediate XML format into database specific format. Database Schema uses Database Driver (EvalPF_DatabaseDriver_SQLServer) and Database Info (EvalPF_DatabaseInfo_SQLServer) to connect to Database Server.

5. Database Target (EvalPF_DatabaseTarget_Database1 and EvalPF_DatabaseTarget_Database2)

Database target is used to specify the database server and name of the database, where the target data is stored. In this Process Flow, SQL Server is used as the database server. Database Target uses Database Schema. EvalPF_DatabaseTarget_Database1 uses EvalPF_DatabaseSchema_Database1 and EvalPF_DatabaseTarget_Database2 uses EvalPF_DatabaseSchema_Database2.

6. File Target (EvalPF_FileTarget_ErrorRecord, EvalPF_FileTarget_InsertError and EvalPF_UpdateError)

In this sample process file targets are used to store error records. Sometime it might be possible that format of the excel file received is not compatible with either of the schemas. In this case records of that excel file is saved into the file specified in EvalPF_FileTarget_ErrorRecord). There could be other possibilities of error while inserting or updating the records in database target. Records which cannot be inserted into database server is stored into the file specified in EvalPF_FileTarget_InsertError. Records, which cannot be updated in database server, is stored in the file specified in EvalPF_FileTarget_UpdateError.

USAGE SCENARIO

This sample Process Flow can be used whenever you wish to process incoming data of different format using different schemas.

DATA DESCRIPTION

Data used in this Process Flow is the sales report, which is in, excel files. There are two formats of excel files. The formats of the Excel files, which contain source data, are displayed in Table 6.1 and Table 6.2 respectively.

Table 6.1: Format 1 of Excel Files used as Source

Field Name	Description	Data Type
Account Number	Account Number can be either 99-999999 or AA-999999 formats. Here 99 denotes any numeric and AA denote any alphabets.	String
Product Code	Product Code	String
Quantity	Quantity of the product specified Product Code Field	Number
Unit Price	Unit Price in US \$	Number

Table 6.2: Format 2 of Excel Files used as Source

Field Name	Description	Data Type
Account Number	Account Number can be either 99-999999 or AA-999999 formats. Here 99 denotes any numeric and AA denote any alphabets.	String
Total Price	Multiplication of Quantity and Unit Price	Number
Product Code	Product Code	String

The fields of both the databases used as target are displayed in the table below.

Table 6.3: Fields of Databases used as Target

Field Name	Description	Data Type
Account Number	Account Number can be either 99-999999 or AA-999999 formats. Here 99 denotes any numeric and AA denote any alphabets. Records with Account Number 99-999999 goes to Database1 and records with Account Number AA-999999 goes to Database2	String
Total Price	Multiplication of Quantity and Unit Price	Number
Product Code	Product Code	String

PREREQUISITES

- SQL Server, which is used as target, must be running.
- Database table must be created as described in the Data Description section. To create the table in target database, you can run the databascript.sql file, located in `../../Solutions/Demo/EvalPF` folder.
- Access to Incoming Mail (POP3) Server specified in Mail Event and Mail Source activities.
- Some activities must be edited before executing the Process Flow. These activities are outlined as:
 - EvalPF_MailEvent_Format1
 - EvalPF_MailEvent_Format2
 - EvalPF_MailSource
 - EvalPF_DataBaseInfo_SQLServer

 To know, how to edit these activities refer to [Editing Activities](#) section.

USING ANOTHER DATABASE SERVER

This sample Process Flow is configured with SQL Server as target. If another database server is to be used as target, following activities need to be changed:

- EvalPF_DatabaseDriver_SQLServer
- EvalPF_DatabaseInfo_SQLServer
- EvalPF_DatabaseTarget_Database1
- EvalPF_DatabaseTarget_Database2

 To know, how to edit these activities refer to [Editing Activities](#) section.

EXECUTION AND MONITORING

This section describes the execution of Sample Process Flow and monitoring its execution. Steps involved to execute this sample Process Flow can be broadly divided as below:

- Activating Mail Events
- Sending mail with subject and attachments specified in Mail Events
- Monitoring Process Flow execution

Activating Mail Events

By default, Mail Events are in *deactivated* state. They must be activated before executing the sample Process Flow.

Steps to activate the Mail Events:

1. In the Adeptia Suite homepage menu, click **[+] Deploy** to expand the tree. All the items in the **Deploy** category are displayed.
2. Click **[+] Events & Triggers** to expand the tree and then click **Mail**. The Manage Mail Event screen is displayed with the list of existing events (see Figure 6.2).

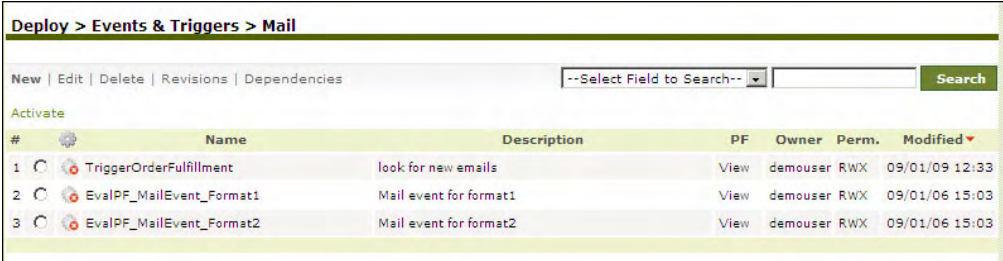

#	Name	Description	PF	Owner	Perm.	Modified
1	TriggerOrderFulfillment	look for new emails	View	demouser	RWX	09/01/09 12:33
2	EvalPF_MailEvent_Format1	Mail event for format1	View	demouser	RWX	09/01/06 15:03
3	EvalPF_MailEvent_Format2	Mail event for format2	View	demouser	RWX	09/01/06 15:03

Figure 6.2: Manage Mail Event

3. To activate the Mail Event (*EvalPF_MailEvent_Format1*), Select the radio button adjacent to *EvalPF_MailEvent_Format1* activity and then click **Activate** link. A screen is displayed confirming that the Mail Event activity has been activated successfully.
4. Similarly, activate another Mail Event (*EvalPF_MailEvent_Format2*).

Sending Mail to execute Process Flow

After Mail Events are activated they start checking specified mailbox for mails. Now to execute the Sample Process Flow, you only need to send the mail with specified subject and attachment to the mailbox. When mail is sent to the mailbox, one of the two Mail Events gets fired and in turn triggers the Process Flow.

Monitoring Process Flow Execution

During execution of the Process Flow you can view status of the Process Flow as well as status of each activity of the Process Flow.

Steps to monitor Process Flow execution:

1. In the Adeptia Suite homepage menu, click **[+] History** to expand the tree. All the items in the **History** category are displayed.

2. Click **Process Flow Log**. The Process Flow Log screen is displayed (refer to Figure 7.4).
3. Select the Process Flow (*EvalPF_ProcessFlow*) from the *Select Process Flow* drop-down list.
4. Click the **Details** button. This displays the list of activities of the selected process flow conforming to the selected criteria (see Figure 6.3).

Reports > Process Flow Log									
Search Criteria									
Start Date	10/05/2007	Start Time	00 : 00	End Date	10/05/2007	End Time	23 : 59		
Process Flow Name	EvalPF_ProcessFlow_SalesReport	Sort By	Name	Status	Executed	Details		Summary	
P/C	Process Flow Name	Description	Status	User ID	Start Time	End Time	Action		
	EvalPF_ProcessFlow_SalesReport	Sales Report - Two ...	Executed	admin	10/05/2007 11:15:30	10/05/2007 11:15:50	<input type="radio"/> ERROR	<input checked="" type="radio"/> INFO	<input type="radio"/> DEBUG
							Details	Repository	Summary

Figure 6.3: Searched Process Flows

 To view the summary of all instances of the process flow execution, click the **Summary** button.

5. Click **Details** in the **Action** column of the activity of which you want to view execution details. This displays the Detailed Process Flow Activity Execution screen (see Figure 6.4).

Process Flow Log Details						
Process Flow Name : EvalPF_ProcessFlow_SalesReport						
Process Flow PID : 192168001007119156313085601271						
Date/Time	Activity Name	Activity Type	Status	Message	Level	Loc
10/05/2007 11:15:50	EvalPF_ProcessFlow_SalesReport	Transaction	Executed	Activity disposed. Start Time:2007-10-05 11:15:30 End Time:2007-10-05 11:15:50 Run Time:19 second(s) 398 ms	INFO	services.Abstrse(AbstractSe
10/05/2007 11:15:50	EvalPF_ProcessFlow_SalesReport	Transaction	Running	Context Information: {EvalPF_FileTarget_UpdateError.params={fileName=U pdateErrors-2007-10-05 11-15-50.txt}, TransactionAddress=localhost://indigo.Transaction [19216800101112204420101200008] 192168001007119156 313085601271};type=Transaction,name=EvalPF_Process Flow_SalesReport,id=19216800101112204420101200008 ,pid=192168001007119156313085601271, EvalPF_FileTarget_ErrorRecord.params={fileName=Er rorRecords-2007-10-05 11-15-45.txt}, currentState=state- BPMN:TASK:BASIC_TASK:11, EvalPF_FileTarget_InsertError.params={fileName=In sertErrors-2007-10-05 11-15-50.txt}, LoggingLevel=INFO}	INFO	services.Abstrse(AbstractSe
10/05/2007 11:15:50	EvalPF_FileTarget_UpdateError	FileTarget	Executed	Activity disposed. Start Time:2007-10-05 11:15:50 End Time:2007-10-05 11:15:50 Run Time:30 ms	INFO	services.Abstrse(AbstractSe
10/05/2007 11:15:50	EvalPF_FileTarget_UpdateError	FileTarget	Running	Execute	INFO	services.Abstrse(AbstractSe
10/05/2007 11:15:50	EvalPF_FileTarget_UpdateError	FileTarget	Running	Initialize	INFO	services.Abstrse(AbstractSe
10/05/2007 11:15:50	EvalPF_FileTarget_InsertError	FileTarget	Executed	Activity disposed. Start Time:2007-10-05 11:15:50 End Time:2007-10-05 11:15:50 Run Time:80 ms. Operation count:588 Bytes Average:7350.0 operations/sec	INFO	services.Abstrse(AbstractSe
10/05/2007 11:15:50	EvalPF_FileTarget_InsertError	FileTarget	Running	Execute	INFO	services.Abstrse(AbstractSe
10/05/2007 11:15:50	EvalPF_FileTarget_InsertError	FileTarget	Running	Initialize	INFO	services.Abstrse(AbstractSe
10/05/2007 11:15:49	EvalPF_DatabaseTarget_Database	DatabaseTarget	Executed	Activity disposed. Start Time:2007-10-05 11:15:47 End Time:2007-10-05 11:15:49 Run Time:2 second(s) 474 ms. Operation count:3 Records Average:1.2126112 operations/sec	INFO	services.Abstrse(AbstractSe

Figure 6.4: View Process Flow Log Details

EDITING ACTIVITIES

Activities used in this sample Process Flow are pre-created. This section describes how to edit these activities.

Editing Mail Events



Mail Event is used to trigger the Process Flow, when a mail with specified subject arrives in a mailbox. In this sample Process Flow two Mail Events are used. When a mail with subject **Format1** arrives in the mailbox, *EvalPF_MailEvent_Format1* gets fired and triggers the Process Flow. When a mail with subject **Format2** arrives in the mailbox, *EvalPF_MailEvent_Format2* gets fired and triggers the same Process Flow.

Steps to edit Mail Events activity:

1. In the Adeptia Suite homepage menu, click **[+] Deploy** to expand the tree. All the items in the **Deploy** category are displayed.
2. Click **[+] Events & Triggers** to expand the tree and then click **Mail**. The Manage Mail Event screen is displayed with the list of existing Mail Events (refer to Figure 6.2).
3. Select the radio button adjacent to Edit *EvalPF_MailEvent_Format1* activity and then click **Edit** link. This displays the Edit *EvalPF_MailEvent_Format1* activity screen, with the properties of the activity displayed in their respective fields (see Figure 6.5).

Deploy > Events & Triggers > Mail > EvalPF_MailEvent_Format1

[-] Standard properties

Name *	<input type="text" value="EvalPF_MailEvent_Format1"/>	
Description *	<input type="text" value="Mail event for format1"/>	
Protocol *	<input type="text" value="POP3"/>	
Incoming Mail Server *	<input type="text" value="pop.mail.server"/>	
Domain	<input type="text"/>	
CDO host machine	<input type="text"/>	
Enable SSL	<input type="checkbox"/>	
Port	<input type="text" value="110"/>	
User Id	<input type="text" value="account@domain"/>	
Password	<input type="password" value="••••"/>	
Confirm Password	<input type="password"/>	
Search based on following filter criteria *		
Sender E-mail	<input type="text" value="sender.mail@domain.com"/>	<input type="checkbox"/> ignoreCase
Mail Subject	<input type="text" value="Format1"/>	<input checked="" type="checkbox"/> ignoreCase
Mail Content	<input type="text"/>	
File Attachment	<input type="text" value="DataExcelFile.xls"/>	<input type="checkbox"/> ignoreCase
Event Start Date (mm/dd/yyyy)	<input type="text"/> 	
Time (hh:mm)	<input type="text" value="Hours"/> <input type="text" value="Mins"/>	
Event Expiry Date (mm/dd/yyyy)	<input type="text"/> 	
Time (hh:mm)	<input type="text" value="Hours"/> <input type="text" value="Mins"/>	
Frequency	<input type="text" value="2"/>	<input type="text" value="Duration"/>
Polling Frequency *	<input type="text" value="2"/>	<input type="text" value="Minute (s)"/>

[+] Advanced properties

* Mandatory fields.

Figure 6.5: Edit *EvalPF_MailEvent_Format1* Activity

A detailed description of fields on this screen is explicated in the table below.

Table 6.4: Details of Fields on Edit Mail Event Screen

Field Name	Field Description
Name	Name of the Mail Event activity
Description	Description of the Mail Event activity
Protocol	Name of the internet protocol used for retrieving incoming mails. It can be POP3, IMAP4 or MAPI.
Incoming Mail Server	Name or IP address of the selected incoming mail server, where Mail Source checks for specified mail. In case MAPI protocol is selected in the <i>Protocol</i> drop-down lists, enter the name of exchange server in the <i>Incoming Mail Server</i> field.
Domain	Enter the domain name. This field is applicable only when MAPI is selected in the protocol drop-down list.
CDO Host Machine	Enter the name of the CDO host machine. CDOConfig.exe is a tool, which comes with the J-Integra for Exchange SDK and is used for configuring CDO. Host where CDO is configured is called CDO host machine.
Enable SSL	Check this checkbox, if the specified mail server is a secure mail server.
Port	Default Port number of the Incoming Mail Server. You can change this if required
User ID	Username required to access the mailbox in which mail with specified subject arrives
Password	Password required to access the mailbox
Confirm Password	Re-enter the Password
Search based on following filter criteria	Select any of the following filter criteria: Sender' Email Address Email address of the sender Subject Subject of mail File Attachment Name of the attached file If you want to ignore the case of subject or the name of file attachment, check the <i>Ignore Case</i> check box displayed next to <i>subject</i> or <i>File attachment field</i> . In this Process Flow Sender's Email Address and Subject is used to specify the mail.
Event Start Date (mm/dd/yyyy)	Date from which Mail Events starts checking the specified mailbox.
Time (hh:mm)	Time from which Mail Events starts checking the specified mailbox.
Event Expiry Date (mm/dd/yyyy)	Date on which Mail event will stop checking for specified mail,
Time (hh:mm)	Time on which Mail Events will stop checking the specified mailbox.
Polling Frequency	Time interval at which Mail Event checks for specified mail

4. Make the necessary changes.

5. Once you have made the required changes, click the **Save** button to save the changes. A screen is displayed confirming that the Mail Event activity has been updated successfully. If the *comments* property is enabled, then clicking **Save** will display a screen where you need to enter comments related to updating the mail event activity (refer to Figure 7.10).
6. Enter the comments in the *Add Comments* field.

	The comment should be at least 1 character in length.
---	---

7. Click **OK** to save the comments. This displays a screen confirming that the mail event activity has been updated successfully.

	Repeat the same steps to edit the <i>EvalPF_MailEvent_Format2</i> activity.
---	---

Editing Mail Source (EvalPF_MailSource)

Mail Source is used to receive mails from the specified mail server. In this Process Flow mail source receives mails from Mail Event. Mail, which is used to trigger the Process Flow, is also used as the source of this Process Flow. Mail Event forwards the mails to Mail Source.

Steps to edit the Mail Source activity:

1. In the Adeptia Suite homepage menu, click **[+] Configure** to expand the tree. All the items in the **Configure** category are displayed.
2. Click **[+] Services** to expand the tree. All the items in the **Services** category are displayed.
3. Click **[+] Source** to expand the tree, and then click **Mail**. The Manage Mail Source screen is displayed with the list of existing Mail Source activities (see Figure 6.6).

Configure > Services > Source > Mail					
New Edit Delete Revisions Dependencies					
--Select Field to Search--					Search
#	Name	Description	Owner	Perm.	Modified
1	<input type="radio"/> ReceiveCustomerOrders	get email with order data file in excel	demouser	RWX	09/01/09 12:28
2	<input type="radio"/> EvalPF_MailSource	mail source	demouser	RWX	08/23/05 13:53

Figure 6.6: Manage Mail Source

4. Select the radio button adjacent to Edit *EvalPF_MailSource* activity and then click **Edit** link. This displays the Edit *EvalPF_MailSource* activity screen, with the properties of the activity displayed in their respective fields (see Figure 6.7).

Configure > Services > Source > Mail > EvalPF_MailSource

[-] Standard properties

Name *	<input type="text" value="EvalPF_MailSource"/>
Description *	<input type="text" value="mail source"/>
Protocol *	<input type="text" value="POP3"/>
Incoming Mail Server *	<input type="text" value="pop.mail.server"/>
Domain	<input type="text"/>
CDO host machine	<input type="text"/>
Enable SSL	<input type="checkbox"/>
Port	<input type="text" value="110"/>
User Id	<input type="text" value="account@domain"/>
Password	<input type="password"/>
Confirm Password	<input type="password"/>
Search based on following filter criteria *	
Sender E-mail	<input type="text"/>
Subject	<input type="text" value="Format1"/>
Mail Content	<input type="text"/>
Data Location*	<input type="text" value="Attachment"/>
File Name	<input type="text" value="DataExcelFile.xls"/>
Leave Copy On Server	<input type="checkbox"/>

[+] Advanced properties

* Mandatory fields.

Save
Save As
Cancel
Test

Figure 6.7: Edit *EvalPF_MailSource* Activity

A detailed description of fields on this screen is explicated in the table below.

Table 6.5: Details of Fields on Edit Mail Source Screen

Field Name	Field Description
Name	Name of the Mail Source activity
Description	Description of the Mail Source activity
Protocol	Name of the internet protocol used for retrieving incoming mails. It can be POP3, IMAP4 or MAPI.
Incoming Mail Server	Name or IP address of the selected incoming mail server, where Mail Source checks for specified mail. In case MAPI protocol is selected in the <i>Protocol</i> drop-down lists, enter the name of exchange server in the <i>Incoming Mail Server</i> field.
Domain	Enter the domain name. This field is applicable only when MAPI is selected in the protocol drop-down list.
CDO Host Machine	Enter the name of the CDO host machine. CDOConfig.exe is a tool, which comes with the J-Integra for Exchange SDK and is used for configuring CDO. Host where CDO is configured is called CDO host machine.
Enable SSL	Check this checkbox, if the specified mail server is a secure mail server.
Port	Default Port number of the Incoming Mail Server. You can change this if required
Subject	Subject of the mail. Here you can enter any subject. During execution of process flow, subject will be overwritten with the subject of the mail, received to Mail Event.
User ID	Username required to access the mailbox in which mail with specified subject arrives
Password	Password required to access the mailbox
Confirm Password	Re-enter the Password
Data Location	Data location specifies that whether data is in body of the email or in attached file
File Name	Name of the attached file, if the data is in attached file.
Leave a Copy on Server	If this option is enabled, a copy of mail is left on the server.

5. Make the necessary changes.
6. Once you have made the required changes, click the **Save** button to save the changes. A screen is displayed confirming that the Mail Source activity has been updated successfully. If the *comments* property is enabled, then clicking **Save** will display a screen where you need to enter comments related to updating the mail source activity (refer to Figure 7.10).
7. Enter the comments in the *Add Comments* field.

	The comment should be at least 1 character in length.
---	---

8. Click **OK** to save the comments. This displays a screen confirming that the mail source activity has been updated successfully.



You can verify the mail source activity at design time by clicking **Test Connection** button.

Editing Excel Schema

Excel Schema is used to parse the data from an excel file attached with incoming mail. Excel Schema parses the data from excel file and converts it into intermediate XML format. In this Process Flow two Excel Schemas are used to parse the data. If the subject of the mail is **Format1**, **EvalPF_ExcelSchema_Format1** is used and if the subject of the mail is **Format2**, **EvalPF_ExcelSchema_Format2** is used.

Steps to edit the Excel Schema (EvalPF_ExcelSchema_Format1) activity:

1. In Adeptia Suite homepage menu, click **[+] Configure** to expand the tree. All the items in the **Configure** category are displayed.
2. Click **[+] Services** to expand the tree. All the items in the **Services** category are displayed.
3. Click **[+] Schema** to expand the tree, and then click **Excel**. The Manage Excel Schema screen is displayed with the list of existing Excel Schemas (refer to Figure 3.15).
4. Select the radio button adjacent to *EvalPF_ExcelSchema_Format1* activity and then click **Edit** link. This displays the Edit *EvalPF_ExcelSchema_Format1* activity screen, with the properties of the activity displayed in their respective fields (see Figure 6.8).

Configure > Services > Schema > Excel > EvalPF_ExcelSchema_Format1

[-] Standard properties

Name *

Description *

Data Header Present

Download Schema Definition File

Create Schema Definition*

Use Definition File

Enter the Fields Sequentially

Sheet Name*

#	FieldName	Type	Format	SubFormat	Data Mode
1	Account_Number	string	mmddyyyy	hh:mm:ss	Plain Text
2	Product_Code	string	mmddyyyy	hh:mm:ss	Plain Text
3	Quantity	number	mmddyyyy	hh:mm:ss	Plain Text
4	Unit_Price	number	mmddyyyy	hh:mm:ss	Plain Text

Number of Rows at Position

Define Hierarchy

[+] Advanced properties

* Mandatory fields.

Figure 6.8: Edit *EvalPF_ExcelSchema_Format1* Activity

A detailed description of fields on this screen is explicated in the table below.

Table 6.6: Details of Fields on Edit Excel Schema Screen

Field Name	Field Description
Name	Name of the Excel Schema
Description	Description of the Excel Schema
Data Header Present	Data Header usually contains the titles of the fields in a file. If you enable this option, Field Names of Excel Schema are written as column's name in target excel file
Sheet Name	Name specified here becomes Book Name of the excel sheet.
Create Schema Definition	Schema can be defined using one of the following options: <ul style="list-style-type: none"> Use Definition File Enter the Field Sequentially Pre-created schema with this sample Process Flow is created using second option i.e. Enter the Field Sequentially
Field Name	Name of the Fields
Data Type	There are three data types:

	String Number Date Currency	String can be used for any type of data. Contains numbers Contains Date and Time Contains Currency Value
Format	If data type is <i>Date</i> , select the data format from <i>Format</i> drop-down list.	
SubFormat	If data type is <i>Date</i> , select time format from <i>SubFormat</i> drop-down list.	
Data Mode	If data is in Plain Text, select <i>Plain Text</i> option. If data is encrypted, then select <i>Encrypted</i> option.	

5. Make the necessary changes.
6. Once you have made the required changes, click the **Save** button to save the changes. A screen is displayed confirming that the Excel Schema activity has been updated successfully. If the *comments* property is enabled, then clicking **Save** will display a screen where you need to enter comments related to updating the excel schema (refer to Figure 7.10).
7. Enter the comments in the *Add Comments* field.

 The comment should be at least 1 character in length.

8. Click **OK** to save the comments. This displays a screen confirming that the excel schema has been updated successfully.

 Repeat the same steps to edit *EvalPF_ExcelSchema_Format2*.

Testing Excel Schema (EvalPF_ExcelSchema)

You can verify the excel schema activity at design time.

Steps to verify schema activity

1. Click **Test** button on the Edit Excel Schema screen. The Test Schema screen is displayed (refer to Figure 7.14).
2. Select the type of schema to test, from the *Type* drop-down list. By default, *Source* is selected.
3. Enter the full path (with file name and extension) of the source excel file in the *Source File Name* field.
4. Enter the full path of the XML target file, where it will be generated, in the *Target File Name* field.

5. Enter the full path of the XML file where errors will be stored, in the *Error File Name* field.
6. Click **Submit** button. This tests the validity of the excel schema.

Editing Mapping Activity

Mapping is used to map data fields of source schema with data fields of target schema. In this Process Flow multiple schemas are used at target end.

Steps to edit the Mapping activity (EvalPF_MappingTransformation_Format1):

1. In Adeptia Suite homepage menu, click **[+] Configure** to expand the tree. All the items in the **Configure** category are displayed.
2. Click **[+] Services** to expand the tree. All the items in the **Services** category are displayed.
3. Click **[+] Data Transform** to expand the tree, and then click **Data Mapping**. The Manage Data Mapping screen is displayed with the list of existing mapping activities (refer to Figure 7.15).
4. Select the radio button adjacent to *EvalPF_MappingTransformation_Format1* activity and then click **Edit** link. This displays the Edit *EvalPF_MappingTransformation_Format1* activity screen with the name and description of the activity displayed in their respective fields (see Figure 6.9).

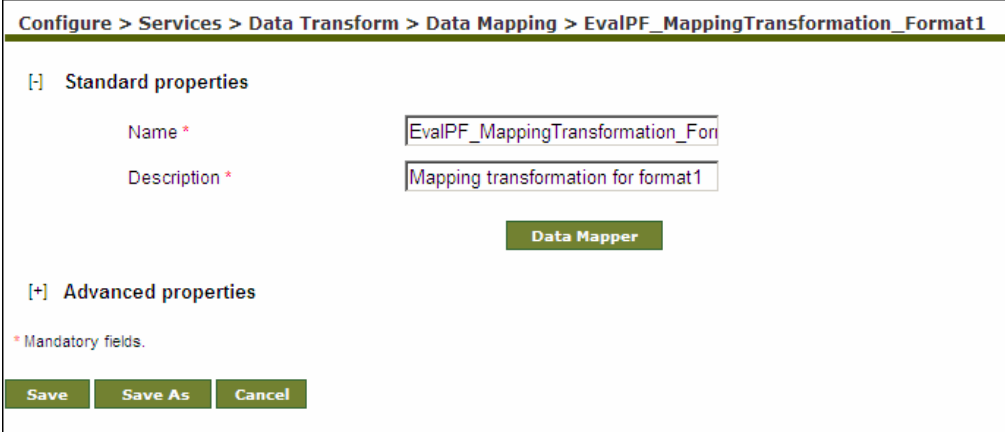

Figure 6.9: Edit *EvalPF_MappingTransformation_Format1* Activity

5. Click the **Data Mapper** button. The Data Mapper applet is displayed showing mapping between data fields of source and target schema (see Figure 6.10).

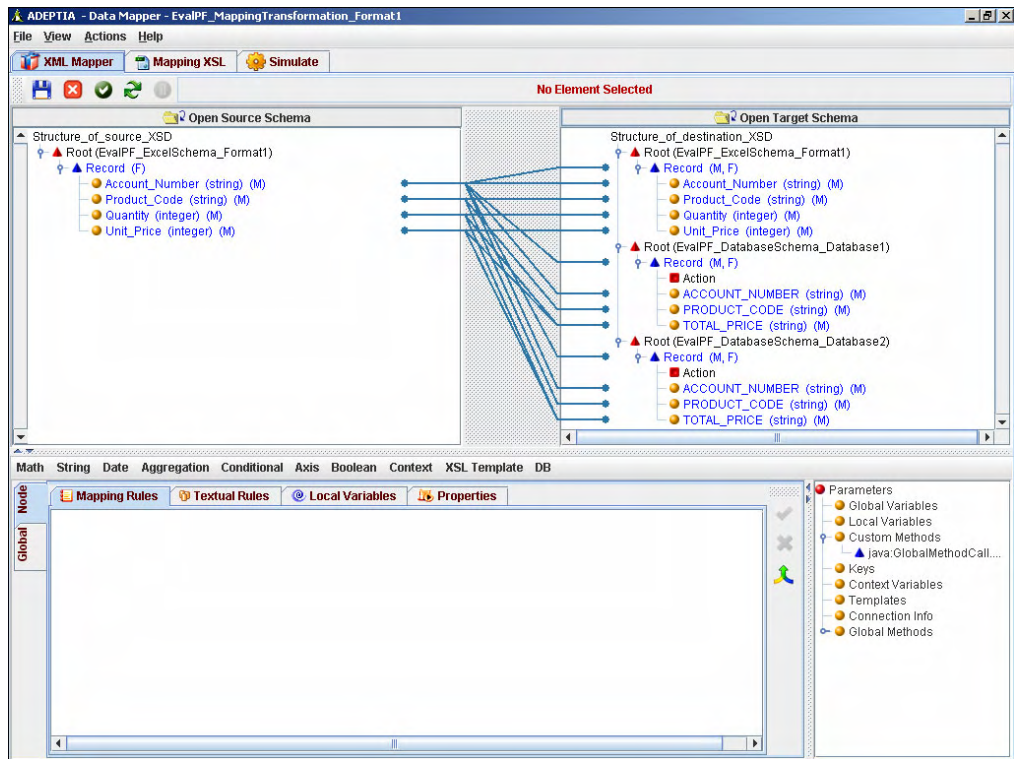

Figure 6.10: Edit *EvalPF_MappingTransformation_Format1* Activity in Data Mapper Applet

6. To view how mapping function is used, click any of the target elements (*Record*) in Target Panel. The mapping function used for the selected element is displayed in the Mapping Graph Area (see Figure 6.11).

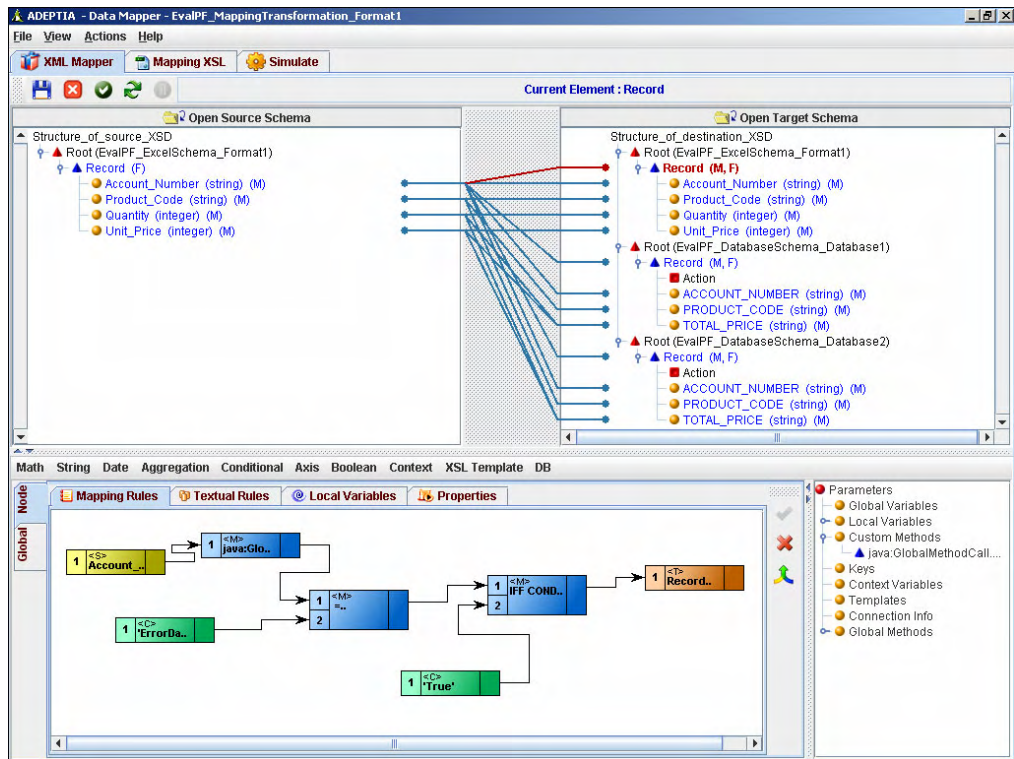

Figure 6.11: View Mapping Functions Used in *EvalPF_MappingTransformation_Format1* Activity

7. To analyze the impact of mapping function on output records, right-click any of function node (**IFF Condition**) and select **Information** (see Figure 6.12).

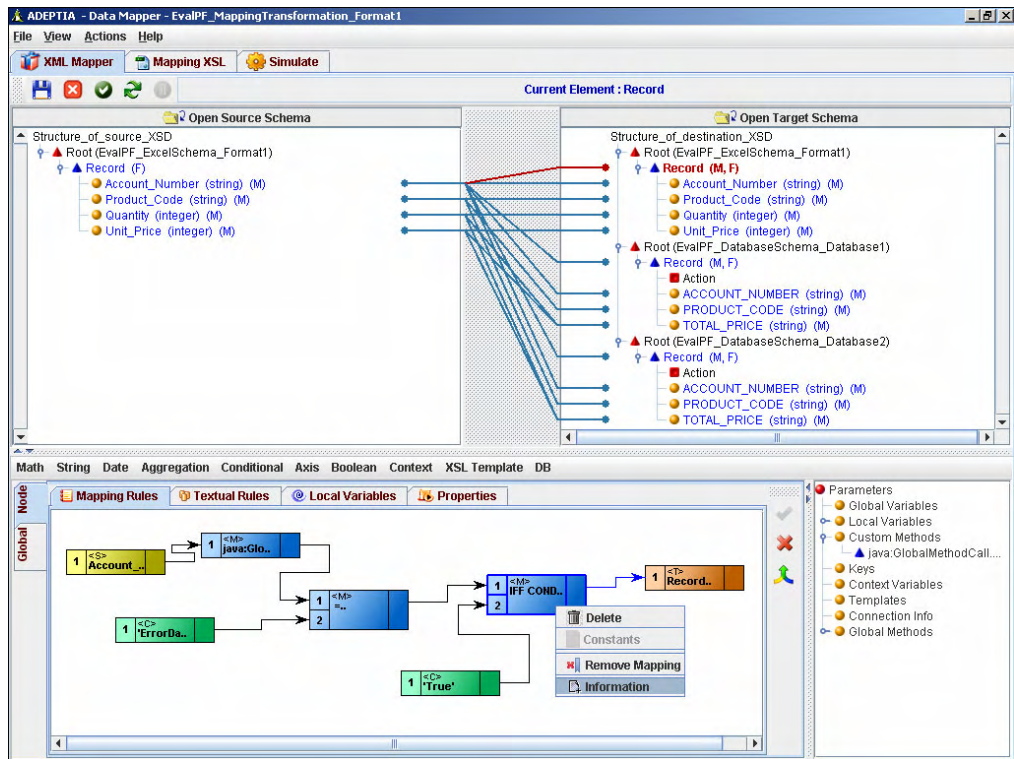

Figure 6.12: Select Mapping Function Information

8. A dialog box is displayed that shows information about that mapping function (see Figure 6.13).

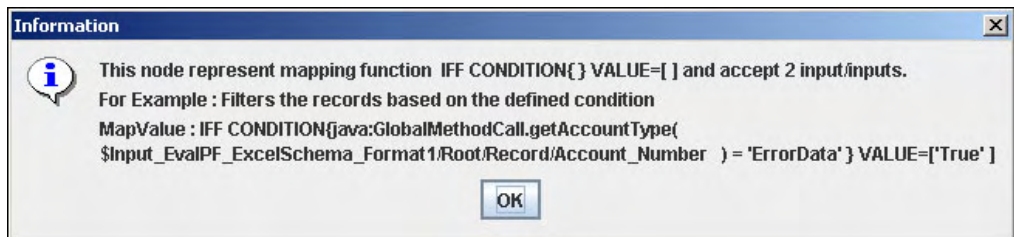

Figure 6.13: View Mapping Function Information

9. Click the **OK** button to close the dialog box.
10. Make the necessary changes to the mapping between the source and target data fields.
11. Once you have made the required changes, save the mapping by clicking the **File** menu and selecting **Save**. A dialog box is displayed confirming that the Mapping activity has been saved successfully.
12. If the *comments* property is enabled, then clicking **Save** will display a screen where you need to enter comments related to the mapping (refer to Figure 7.18).
13. Enter the comments in the *Specify comments for mapping object (object name)* field.



The comment should be at least 1 character in length.

14. Click **OK** to save the comments. This displays a dialog box confirming that the mapping has been saved successfully.



Alternately, you can save the mapping by clicking **Save** () button on the Tool Bar.

15. Exit the Data Mapper applet by clicking the **File** menu and selecting **Exit**.



Repeat the same steps, to edit *EvalPF_MappingTransformation_Format2* activity.



To know, how this mapping activity has been created, refer to [Creating Mapping Activity](#) section.

Editing Database Driver (EvalPF_DatabseDriver_SQLServer)

Database Driver is used to specify the type of database and to upload driver jar files required to connect to that database.

Steps to edit Database Driver:

1. In the Adeptia Suite homepage menu, click **[+] Configure** to expand the tree. All the items in the **Configure** category are displayed.
2. Click **[+] Service** to expand the tree and then click **[+] Connector**. All the items in the **Connector** category are displayed.
3. Click **Database Driver**. The Manage Database Driver screen is displayed with the list of existing Database Drivers (refer to Figure 7.19).
4. Select the radio button adjacent to *EvalPF_DatabseDriver_SQLServer* activity and then click **Edit** link. This displays the Edit *EvalPF_DatabseDriver_SQLServer* activity screen, with the properties of the activity displayed in their respective fields (see Figure 6.14).

Connector > Database Driver > EvalPF_DatabaseDriver_SQLServer

[-] Standard properties

Name *	EvalPF_DatabaseDriver_SQLServer	
Description *	SQL server driver microsoft	
Upload Driver Jar/Zip files	mssqlserver.jar,msbase.jar,msutil.jar	<input type="button" value="Browse Jars"/>
Driver Main Class Name *	com.microsoft.jdbc.sqlserver.SQLSe	<input type="button" value="Get Driver Class..."/>

[+] Advanced properties

* Mandatory fields.

Figure 6.14: Edit *EvalPF_DatabaseDriver_SQLServer*

A detailed description of fields on this screen is explicated in the table below.

Table 6.7: Details of Fields on Edit Database Driver Screen

Field Name	Field Description												
Name	Name of the Database Driver												
Description	Description of the Database Driver												
Upload Driver Jar Files	<p>JDBC Driver files, which are used to connect Database Server. Click the Browse Jars button to select Jar files. Following is the list of databases and the required Jar files:</p> <table style="width: 100%; border-collapse: collapse; margin-top: 5px;"> <tr> <td style="padding: 2px 10px 2px 10px;">Oracle</td> <td style="padding: 2px 10px 2px 10px;">Ojdbc5.jar</td> </tr> <tr> <td style="padding: 2px 10px 2px 10px;">IBM DB2 (Ver 7.1)</td> <td style="padding: 2px 10px 2px 10px;">db2java.zip (7.1 version)</td> </tr> <tr> <td style="padding: 2px 10px 2px 10px;">IBM DB2 (Ver 8.1)</td> <td style="padding: 2px 10px 2px 10px;">db2jcc.jar</td> </tr> <tr> <td style="padding: 2px 10px 2px 10px;">MS SQL</td> <td style="padding: 2px 10px 2px 10px;">msbase.jar, mssqlserver.jar and msutil.jar</td> </tr> <tr> <td style="padding: 2px 10px 2px 10px;">JTDS- SQL Server</td> <td style="padding: 2px 10px 2px 10px;">Jtds.jar</td> </tr> <tr> <td style="padding: 2px 10px 2px 10px;">HSQL DB</td> <td style="padding: 2px 10px 2px 10px;">hsqldb-1.7.2.jar</td> </tr> </table>	Oracle	Ojdbc5.jar	IBM DB2 (Ver 7.1)	db2java.zip (7.1 version)	IBM DB2 (Ver 8.1)	db2jcc.jar	MS SQL	msbase.jar, mssqlserver.jar and msutil.jar	JTDS- SQL Server	Jtds.jar	HSQL DB	hsqldb-1.7.2.jar
Oracle	Ojdbc5.jar												
IBM DB2 (Ver 7.1)	db2java.zip (7.1 version)												
IBM DB2 (Ver 8.1)	db2jcc.jar												
MS SQL	msbase.jar, mssqlserver.jar and msutil.jar												
JTDS- SQL Server	Jtds.jar												
HSQL DB	hsqldb-1.7.2.jar												
Driver Main Class Name	<p>Driver Main Class Name is a fully qualified java class name for the main database driver class. The driver class name typically starts with a <code>com.</code>, <code>net.</code> or <code>org.</code> followed by the company domain, for example the JDBC driver class from <code>mysql.com</code> is called <code>com.mysql.jdbc.Driver</code>. Click the Help button to select Driver Main Class Name from the drop-down list. Following is the list of Driver Main Class Name of different databases:</p>												

Oracle	oracle.jdbc.driver.OracleDriver
SQLSERVER	com.microsoft.jdbc.sqlserver.SQLServerDriver
IBM-DB2SERVER-V7	COM.ibm.db2.jdbc.net.DB2Driver
IBM-DB2-SERVER-V8	com.ibm.db2.jcc.DB2Driver
HSQL	org.hsqldb.jdbcDriver
JTDS-SQLSERVER	net.sourceforge.jtds.jdbc.Driver
AS400	sun.jdbc.odbc.JdbcOdbcDriver
MYSQL	com.ibm.as400.access.AS400JDBCDriver
	com.mysql.jdbc.Driver

5. Make the necessary changes.
6. Once you have made the required changes, click the **Save** button to save the changes. A screen is displayed confirming that the Database Driver has been updated successfully. If the *comments* property is enabled, then clicking **Save** will display a screen where you need to enter comments related to updating the Database Driver (refer to Figure 7.10).
7. Enter the comments in the *Add Comments* field.



The comment should be at least 1 character in length.

8. Click **OK** to save the comments. This displays a screen confirming that the database driver has been updated successfully.



In this sample Process Flow *SQL Server* is used as target database. If you want to use another database, upload the appropriate Jar files and select Driver Main Class Name for that database.

Editing Database Info (EvalPF_DatabselInfo_SQLServer)

Database Info activity is used to specify JDBC URL and Username and Password to access the database. Database Info uses Database Driver to connect to specified Database Server.

Steps to edit the Database Info:

1. In the Adeptia Suite homepage menu, click **[+] Configure** to expand the tree. All the items in the **Configure** category are displayed.
2. Click **[+] Service** to expand the tree and then click **[+] Connector**. All the items in the **Connector** category are displayed.
3. Click **Database Info**. The Manage Database Info screen is displayed with a list of existing **Database Info** (refer to Figure 7.21).

4. Select the radio button adjacent to *EvalPF_DataBaseInfo_SQLServer* activity and then click **Edit** link. This displays the *EvalPF_DataBaseInfo_SQLServer* activity screen, with the properties of the activity displayed in their respective fields (see Figure 6.15).

Configure > Services > Connector > Database Info > EvalPF_DataBaseInfo_SQLServer

[-] Standard properties

Name *

Description *

Select JDBC Driver*

Use Existing ▼

Create New Create Database Driver

Server URL * Help...

User *

Password

Confirm Password

Test Database Connection

[+] Advanced properties

* Mandatory fields.

Save
Save As
Cancel

Figure 6.15: Edit *EvalPF_DatabaseInfo_SQLServer*

A detailed description of fields on this screen is explicated in the table below.

Table 6.8: Details of Fields on Edit Database Info Screen

Field Name	Field Description
Name	Name of the Database Info
Description	Description of the Database Info
JDBC Driver	Database Driver is created to connect to the database Server. For more details refer to section Editing Database Driver .
Server URL	Server URL or JDBC URL points to a specific database on a specified database server. There is no standard for JDBC URL. Every JDBC driver uses a slightly different syntax. For Example a JDBC URL for a MySQL database using the <code>com.mysql.jdbc.Driver</code> direct from MySQL might look like this: <code>jdbc:mysql://localhost/databaseName.</code> To specify Server URL, Click the Help button and enter the following information:

	Database Type	Type of the database
	Host Name	Name of the server on which database server is running
	Port	Port at which database server is running
	Database Name	Name of the database
Following is the list of Server URL's of different databases:		
	Oracle	jdbc:oracle:thin:@databaseserver:1521:orcl
	IBM DB2 (Ver 7.1)	jdbc:db2://databaseserver:6789/TOOLSDB
	IBM DB2 (Ver 8.1)	jdbc:db2://databaseserver:50000/TOOLSDB
	MS SQL	jdbc:microsoft:sqlserver://databaseserver:1433;DatabaseName=master
	SQL JTDS	jdbc:jtds:sqlserver://databaseserver:1433/master
	MS Access	jdbc:odbc:Driver={Microsoft Access Driver (*.mdb)}; DBQ=c:/test/db1.mdb
	MS Excel	Jdbc:odbc:ExcelJDBCtest where <i>ExcelJDBCtest</i> is the ODBC object that you need to create using DSN.
	HSQL DB	jdbc:hsqldb:hsq://databaseserver:2476
Here database server is the name of the server where database is running.		

5. Make the necessary changes.
6. Once you have made the required changes, click the **Save** button to save the changes. A screen is displayed confirming that the Database Info has been updated successfully. If the *comments* property is enabled, then clicking **Save** will display a screen where you need to enter comments related to updating the Database Info (refer to Figure 7.10).
7. Enter the comments in the *Add Comments* field.

	The comment should be at least 1 character in length.
---	---

8. Click **OK** to save the comments. This displays a screen confirming that the database Info has been updated successfully.

	In this sample Process Flow <i>SQL Server</i> is used as target database. If you want to use another database, select appropriate Server URL for that database.
---	---

Editing Database Schema

Database Schema defines the structure of database table. Database Schema is used to define how records can be read from a database table or can be written into a database to table. In this sample process Database Schema is being used at target end. At the target end it converts data from intermediate XML format into database specific format. Database Schema uses Database Info activity to connect to the database Server. This should be noted that Database Schema does not directly take part in creation of Process Flow. It is used by Database Target activity and the Database Target activity is used in Process Flow.

Steps to edit the Database Schema

(EvalPF_DatabaseSchema_Database1) activity:

1. In Adeptia Suite homepage menu, click **[+] Configure** to expand the tree. All the items in the **Configure** category are displayed.
2. Click **[+] Services** to expand the tree. All the items in the **Services** category are displayed.
3. Click **[+] Schema** to expand the tree, and then click **Database**. The Manage Adv. Database Schema screen is displayed with a list of existing Database Schemas (refer to Figure 7.23).
4. Select the radio button adjacent to *EvalPF_DatabaseSchema_Database1* activity and then click **Edit** link. This displays the Edit *EvalPF_DatabaseSchema_Database1* activity screen, with the properties of the activity displayed in their respective fields (see Figure 6.16).

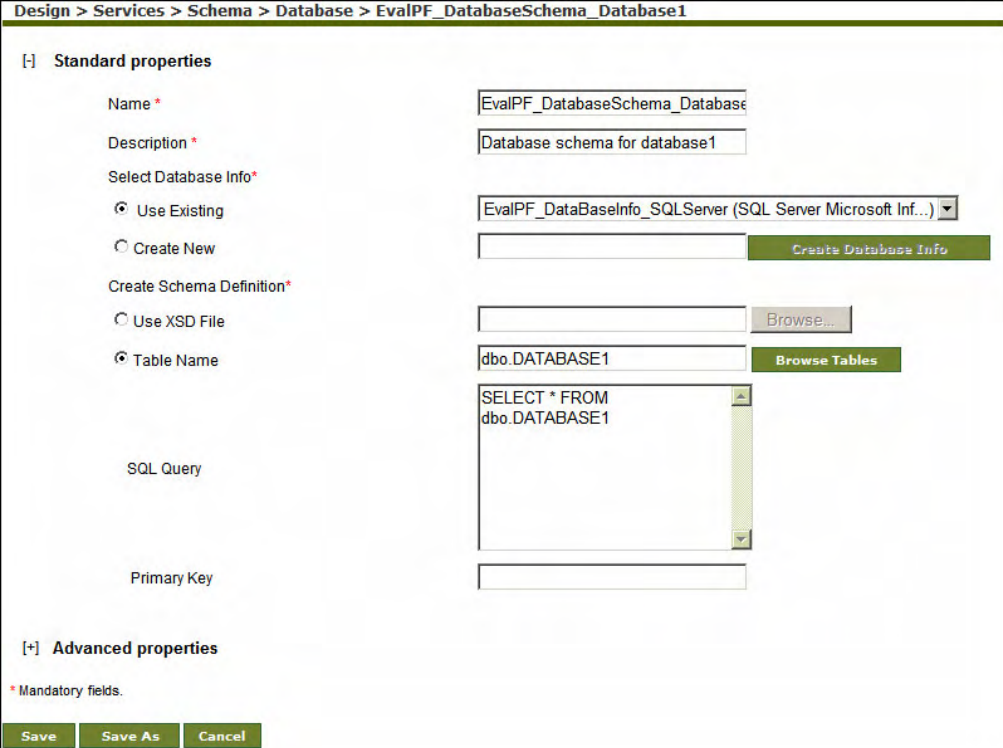

Design > Services > Schema > Database > EvalPF_DatabaseSchema_Database1

[] Standard properties

Name *

Description *

Select Database Info*

Use Existing

Create New

Create Schema Definition*

Use XSD File

Table Name

SQL Query

Primary Key

[+] Advanced properties

* Mandatory fields.

Figure 6.16: Edit *EvalPF_DatabaseSchema_Database1* Activity

A detailed description of fields on this screen is explicated in the table below.

Table 6.9: Details of Fields on Edit Database Schema Screen

Field Name	Field Description
Name	Name of the Database Schema
Description	Description of the Database Schema
Database Info	Database Info created to connect to the specified Database Server. For more details refer to Editing Database Info section.
Create Schema Definition	<p>Schema Definition can be created using one of the following options:</p> <ul style="list-style-type: none"> ▪ Use XSD File ▪ Table Name <p>Database Schema used in this Process Flow is created using second option i.e. Table Name. To select database tables, select Table Name radio button and then Click the Browse Tables. <i>Select Table</i> screen is displayed with the list of database Table. Select the required table and click Get Columns button. Click Close button to close the <i>Select Table</i> screen and return to Database Schema screen.</p> <p>SQL Query box automatically gets populated after selecting database tables.</p>

5. Make the necessary changes.
6. Once you have made the required changes, click the **Save** button to save the changes. A screen is displayed confirming that the Database Source has been updated successfully. If the *comments* property is enabled, then clicking **Save** will display a screen where you need to enter comments related to updating the database source activity (refer to Figure 7.10).
7. Enter the comments in the *Add Comments* field.

	The comment should be at least 1 character in length.
---	---

8. Click **OK** to save the comments. This displays a screen confirming that the database source activity has been updated successfully.

	Repeat the same steps to edit <i>EvalPF_DatabaseSchema_Database2</i> activity.
---	--

Editing Database Target

Database Target is used to insert data into a database server. Database Target uses Database Info for Server URL and login information and Database Schema to get information for database tables and data type etc.

Steps to edit the Database Target (EvalPF_DatabaseTarget_Database1):

1. In the Adeptia Suite homepage menu, click **[+] Configure** to expand the tree. All the items in the **Configure** category are displayed.
2. Click **[+] Services** to expand the tree. All the items in the **Services** category are displayed.
3. Click **[+] Target** to expand the tree, and then click **Database**. The Manage Database Target screen is displayed with the list of existing Database Target activities (refer to Figure 7.25).
4. Select the radio button adjacent to *EvalPF_DatabaseTarget_Database1* activity and then click **Edit** link. This displays the Edit *EvalPF_DatabaseTarget_Database1* activity screen, with the properties of the activity displayed in their respective fields (see Figure 6.17).

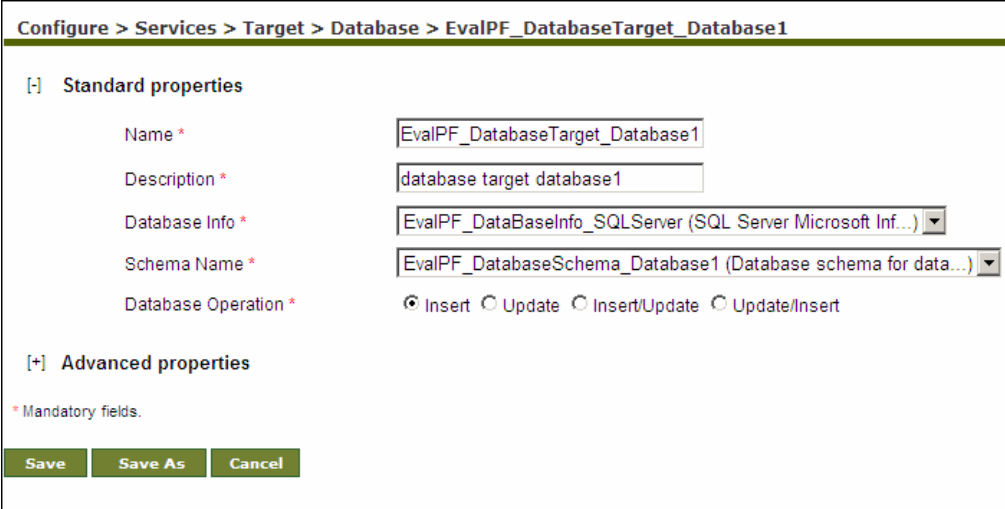

Figure 6.17: Edit *EvalPF_DatabaseTarget_Database1* Activity

A detailed description of fields on this screen is explicated in the table below.

Table 6.10: Details of Fields on Edit Database Target Screen

Field Name	Field Description
Name	Name of the Database Target
Description	Description of the Database Target
Database Info	Database Info created to connect to the specified Database Server. For more details refer to Editing Database Info section.
Schema Name	Database Schema, which describes the structure of database table. For more details refer to Editing Database Schema section.

Database Operation	<p>Database operation specifies how data records are inserted into database tables. Select one of the following database operations:</p> <ul style="list-style-type: none"> ▪ Insert ▪ Update ▪ Insert/Update ▪ Update/Insert <p>When Insert option is selected, records are inserted into the database tables. If records already exist in the database table, new records are added in the database table along with existing records. When a column e.g. <i>Account Number</i> of database table is marked as Primary Key, more than one record cannot exist in the database table for the same Account Number. In this case if data of an Account Number already exist, insert operation fails and data is not inserted into the database.</p> <p>Update option is selected when you want to update the existing record. To use updated option a column of database must be marked as Primary Key. When Update option is selected, database target first checks which column of the database table is marked as Primary Key. Suppose Account Number column is marked as Primary Key. Now database target check whether data of a particular Account Number exist or not. If data for that account number already exists, database target updates the existing records. If none of the column is marked as Primary key, Update operation fails.</p> <p>When Insert/Update option is selected, database target first tries to insert the data into database table. If insert operation fails, database target tries to update the data.</p> <p>When Update/Insert option is selected, database target first tries to update the database table. If update operation fails, database target tries to insert the data.</p> <p><i>Note:</i> To know, how to mark a column of a database table as Primary Key, refer to the documentation of Database Server you are using.</p> <p>In this sample Process Flow Update/Insert option is used.</p>
--------------------	---

5. Make the necessary changes.
6. Once you have made the required changes, click the **Save** button to save the changes. A screen is displayed confirming that the Database Target activity has been updated successfully. If the *comments* property is enabled, then clicking **Save** will display a screen where you need to enter comments related to updating the database target activity (refer to Figure 7.10).
7. Enter the comments in the *Add Comments* field.

	The comment should be at least 1 character in length.
---	---

8. Click **OK** to save the comments. This displays a screen confirming that the database target activity has been updated successfully.

Repeat the same steps to edit *EvalPF_DatabaseTarget_Database2* activity.

Editing File Target Activity

In this Process Flow file target activities are used to store error records. *EvalPF_FileTarget_ErrorRecords* activity is used to store those records, which do not match either of the Account Number format (i.e. 99-999999 or AA-99999). Records, which cannot be inserted into the Database1, are stored in *EvalPF_FileTarget_InsertError*. Records, which cannot be updated into the Database2, are stored in *EvalPF_FileTarget_UpdateError*.

Steps to edit the File Target:

1. In the Adeptia Suite homepage menu, click **[+] Configure** to expand the tree. All the items in the **Configure** category are displayed.
2. Click **[+] Services** to expand the tree. All the items in the **Services** category are displayed.
3. Click **[+] Target** to expand the tree, and then click **File**. The Manage File Target screen is displayed with the list of existing File Target activities (refer to Figure 3.17).
4. Select the radio button adjacent to *EvalPF_FileTarget_ErrorRecords* activity and then click **Edit** link. This displays the Edit *EvalPF_FileTarget_ErrorRecords* activity screen, with the properties of the activity displayed in their respective fields (see Figure 6.18).

Configure > Services > Target > File > EvalPF_FileTarget_ErrorRecord

[-] Standard properties

Name *	<input type="text" value="EvalPF_FileTarget_ErrorRecord"/>
Description *	<input type="text" value="Erroneous records in input excel"/>
File Path *	<input type="text" value="\\Solutions\Demo\EvalPF"/>
File Name *	<input type="text" value="ErrorRecord.txt"/>

[+] Advanced properties

* Mandatory fields.

Save	Save As	Cancel	Test
------	---------	--------	------

Figure 6.18: Edit *EvalPF_FileTarget_ErrorRecord* Activity

A detailed description of fields on this screen is explicated in the table below.

Table 6.11: Details of Fields on Edit File Target Screen

Field Name	Field Description
Name	Name of the File Target
Description	Description of the File Target
File Path	Path of the target file. For example: ../../../../Solutions/Demo/EvalPF/ In the activities <i>EvalPF_FileTarget_InsertError</i> and <i>EvalPF_FileTarget_UpdateError</i> , the path will be ../../../../Solutions/Demo/EvalPF/ and ../../../../Solutions/Demo/EvalPF/ respectively.
File Name	Name of the target file.

5. Make the necessary changes.
6. Once you have made the required changes, click the **Save** button to save the changes. A screen is displayed confirming that the File Target Activity has been updated successfully. If the *comments* property is enabled, then clicking **Save** will display a screen where you need to enter comments related to updating the file target activity (refer to Figure 7.10).
7. Enter the comments in the *Add Comments* field.

	The comment should be at least 1 character in length.
---	---

8. Click **OK** to save the comments. This displays a screen confirming that the file target activity has been updated successfully.

	Repeat the same steps to edit <i>EvalPF_FileTarget_InsertError</i> and <i>EvalPF_FileTarget_UpdateError</i> activities.
---	---

	You can verify the file target activity at design time by clicking Test Connection button. This verifies the values in the <i>File Path</i> and <i>Filename</i> fields and checks whether the file actually exists in the specified location.
---	--

CREATING MAPPING ACTIVITY

Mapping is used to map data fields of source schema and target schema. In this Process Flow, two mapping activities are used. When the subject of the incoming mail is Format1, the mapping activity *EvalPF_MappingTransformation_Format1* is used. When the subject of the incoming mail is Format2, the mapping activity *EvalPF_MappingTransformation_Format2* is used.

In both the mapping activities, Excel Schema is used at the source end. At the target end three schemas (one excel schema that is also being used at source end and two database schemas) are used. Excel Schema is used to define the structure of target excel file, which is created in case format of the *Account_Number* field is not correct. Database Schemas are used to define the structure of two different database tables.

In both the mapping activity a Global Method is used, which calls a Java Method. This java method returns different values based on the format of Account_Number. If the format of account number is 99-999999, the Java method returns the value *NumericNumeric*. If the format of account number is AA-999999, the Java method returns the value *AlphabetNumeric*. Here AA denotes any alphabet and 999999 denotes any numeric value. If the format of Account_Number is different than either of these two formats, the Java Method returns the value *ErrorData*. The records are sent to one of the three target activities depending upon the value returned by the Java Method as shown in the table below.

Table 6.12: Target Activities and Java Method Values

Format of Account_Number	Values returned by Java Method	Target Activities
99-999999	NumericNumeric	EvalPF_DatabaseTarget_Database1
AA-999999	AlphabetNumeric	EvalPF_DatabaseTarget_Database2
Other Format	ErrorData	EvalPF_FileTarget_ErrorRecord

Steps to create the Mapping Activity:

1. In the Adeptia Suite homepage menu, click **[+] Configure** to expand the tree. All the items in the **Configure** category are displayed.
2. Click **[+] Services** to expand the tree. All the items in the **Services** category are displayed.
3. Click **[+] Data Transform** to expand the tree, and then click **Data Mapping**. The Manage Data Mapping screen is displayed with the list of existing mapping activities (refer to Figure 7.15).
4. Click **New Mapping Transformation** button. The Create Mapping Activity screen is displayed (refer to Figure 3.21).
5. Enter the name and description of the new mapping activity in the *Name* and *Description* fields respectively.
6. Click **Data Mapper** button. This displays the Data Mapper applet (refer to Figure 3.22).
7. Click **Open Source Schema** button to load the source schema. This displays the Select Schema screen (refer to Figure 3.23).
8. Select the Source Schema (*EvalPF_ExcelSchema_Format1*) checkbox from the *Source Schema* list and click **Load** button. This loads the selected schema in the Source Panel of the Data Mapper applet.
9. Similarly, load the Target Schemas (*EvalPF_ExcelSchema_Format1*, *EvalPF_DatabaseSchema_Database1*, *EvalPF_DatabaseSchema_Database2*) from the *Target Schema* list.
10. Click (🔍) to expand the tree structure for Source Schema and the Target Schema (see Figure 6.19).

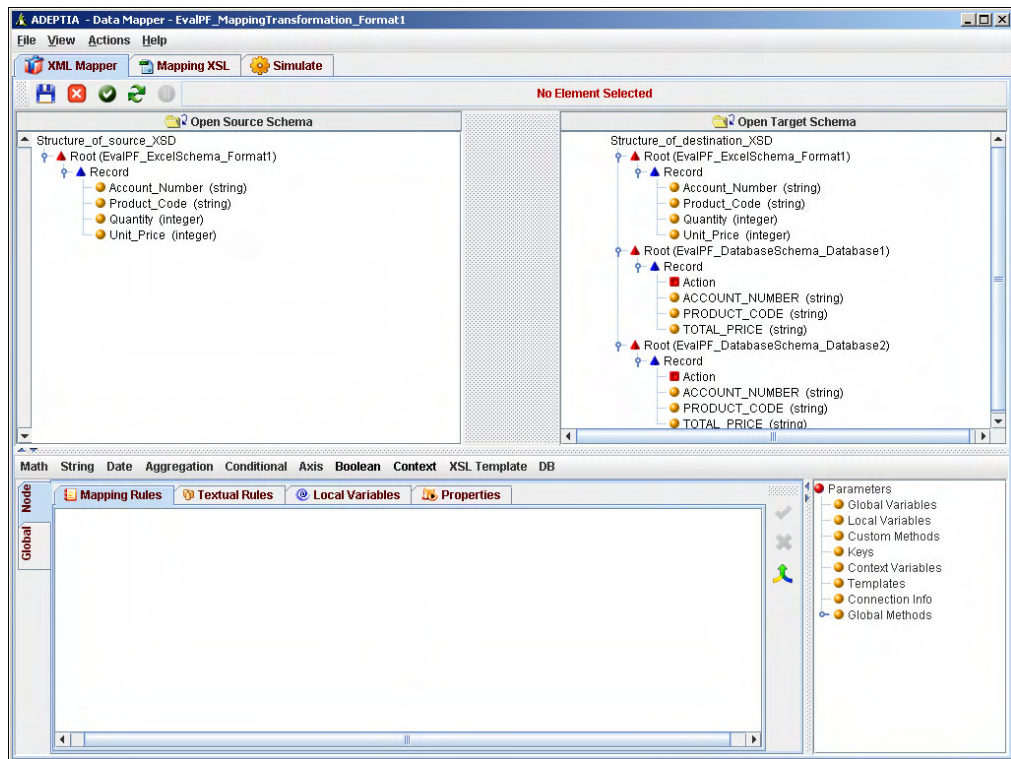

Figure 6.19: Expand Source and Target Schemas

11. Select the **Record** element of the first target schema and then click **Properties** tab in the Mapping Graph Area.
12. Click the **For Each** field and then double-click the **Record** element of the source schema. Click **Save Properties** to save the *For Each* property (see Figure 6.20).

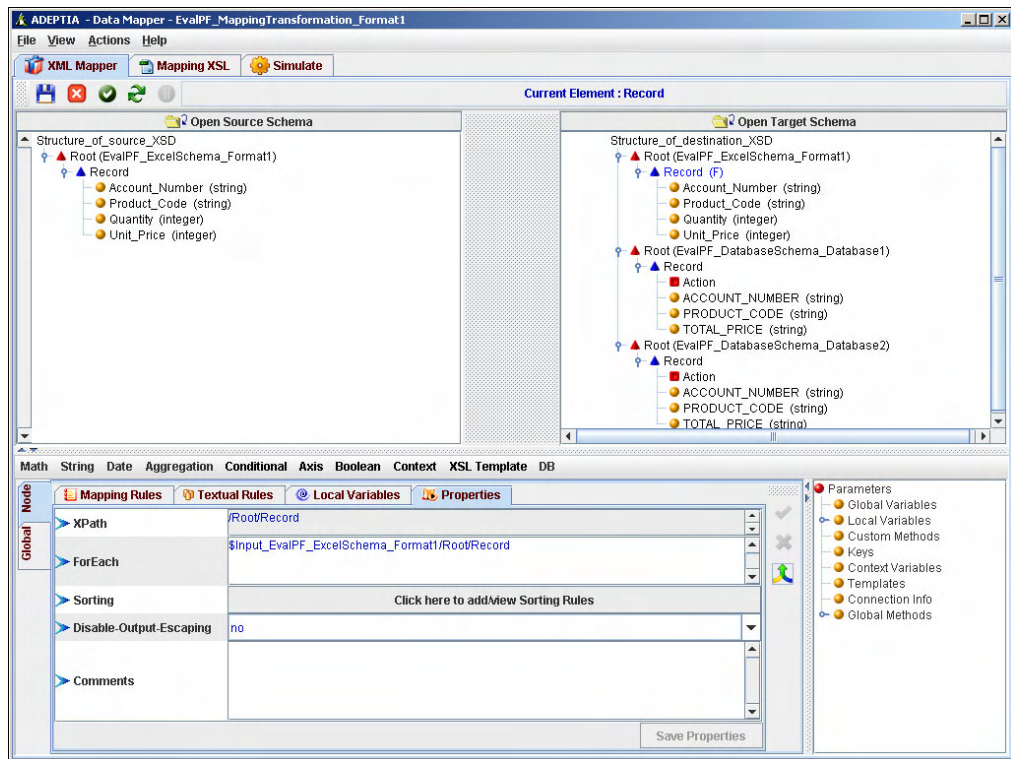

Figure 6.20: Apply For Each Property

13. Similarly, apply the *For Each* property on the **Record** element of the second and third target schemas.
14. Click the **Account_Number** node in the Source Panel, and drag the mouse pointer to the **Account_Number** node of the first schema in the Target Panel (see Figure 6.21).

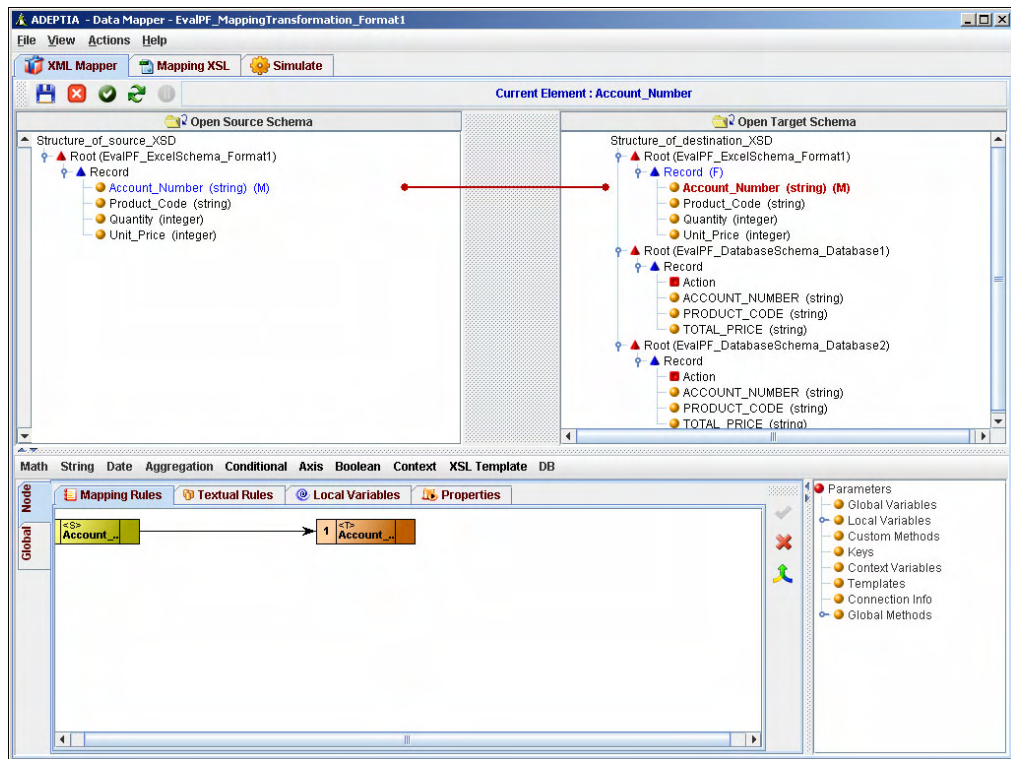

Figure 6.21: Map Account Numbers

15. Similarly, click the **Product_Code** node in the Source Panel and drag the mouse pointer to the **Product_Code** node of the first schema in the Target Panel.
16. Click the **Quantity** node in the Source Panel and drag the mouse pointer to the **Quantity** node of the first schema in the Target Panel.
17. Now click the **Unit_Price** node in the Source Panel and drag the mouse pointer to the **Unit_Price** node of the first schema in the Target Panel (see Figure 6.22).

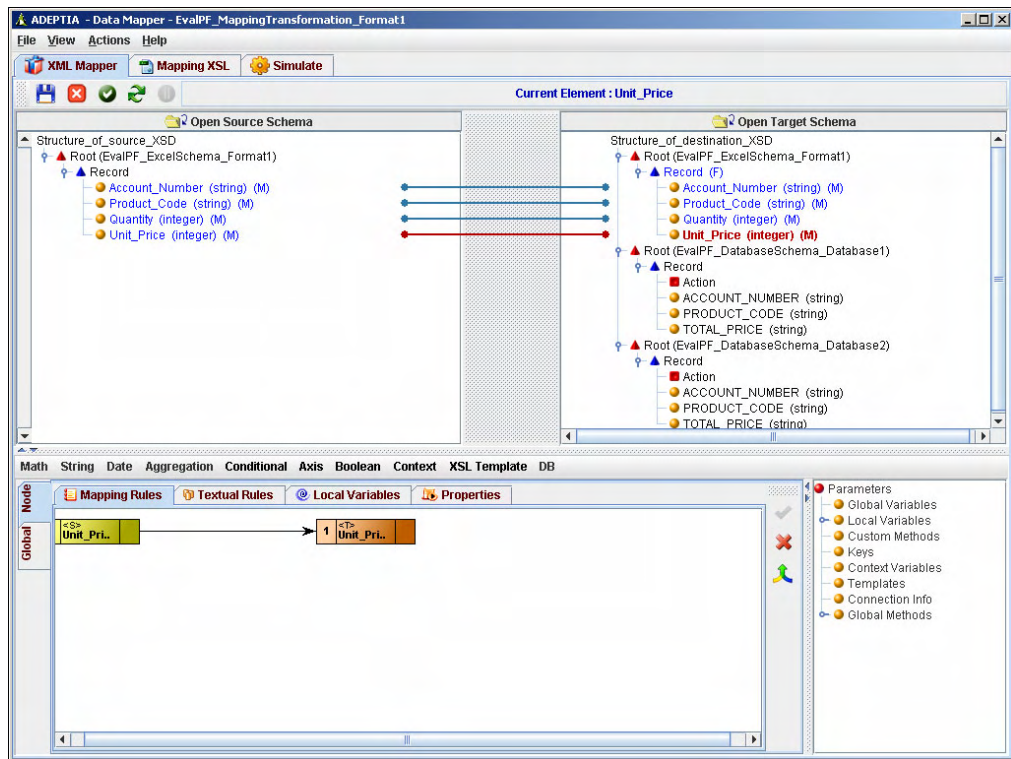

Figure 6.22: Map Source and Target Elements of First Target Schema

18. Similarly, map the fields of the schema in the Source Panel to the fields of the second and third schemas in the Target Panel (see Figure 6.23).

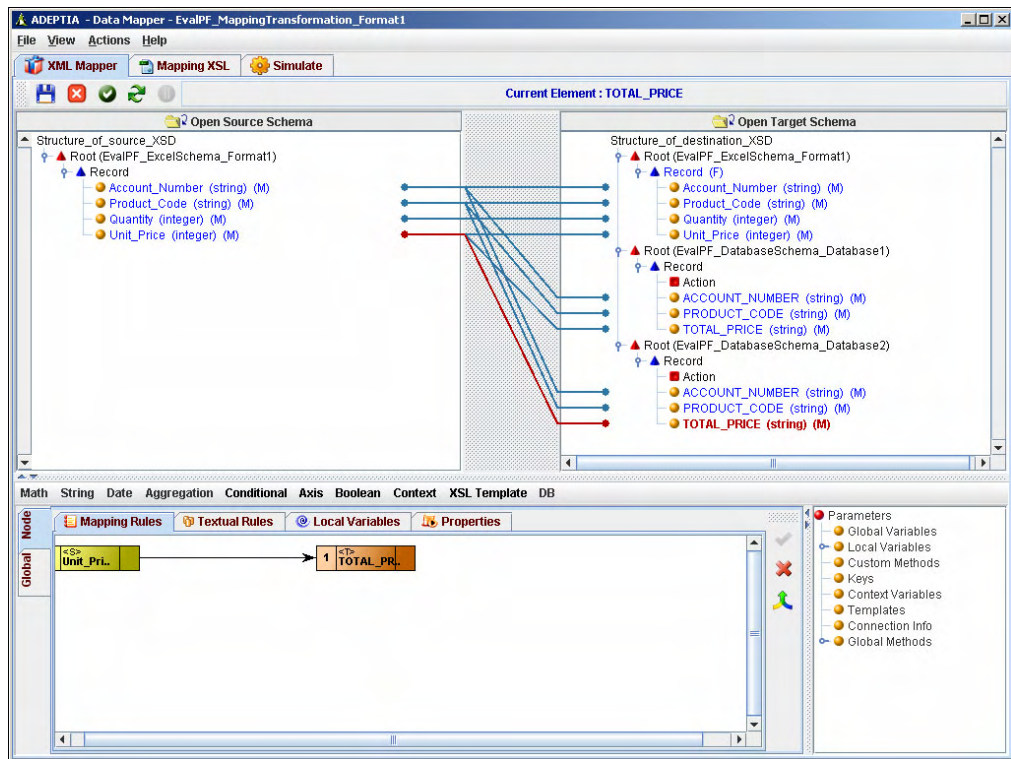

Figure 6.23: Mapping Source and Target Elements of All Target Schemas

19. To filter the records based on *Account_Number* field of the source schema, Custom Method is used.
20. To define a Custom Method, click the **Global** tab in the Mapping Graph Area.
21. Click the **Custom Methods** tab. The Custom Methods Panel is displayed (see Figure 6.24).

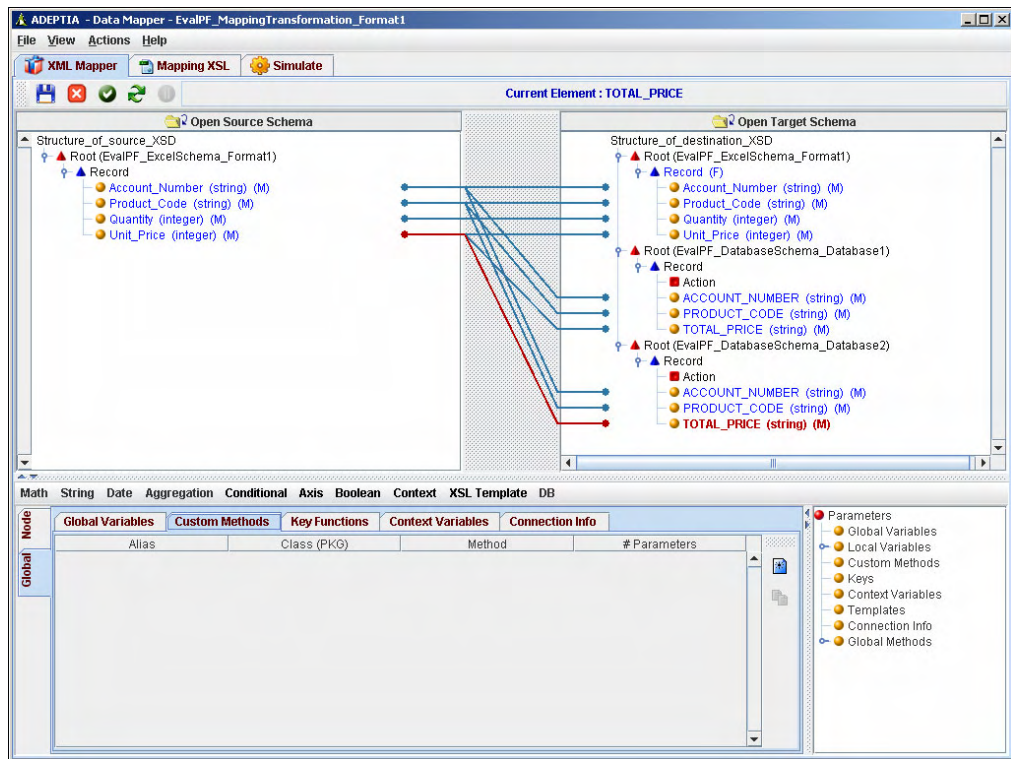



Figure 6.24: Custom Methods Pane

22. Click the **Add Method** () button to add a Custom Method. A row is inserted with following columns (see Figure 6.25):

- Alias
- Class (PKG)
- Method
- # Parameters

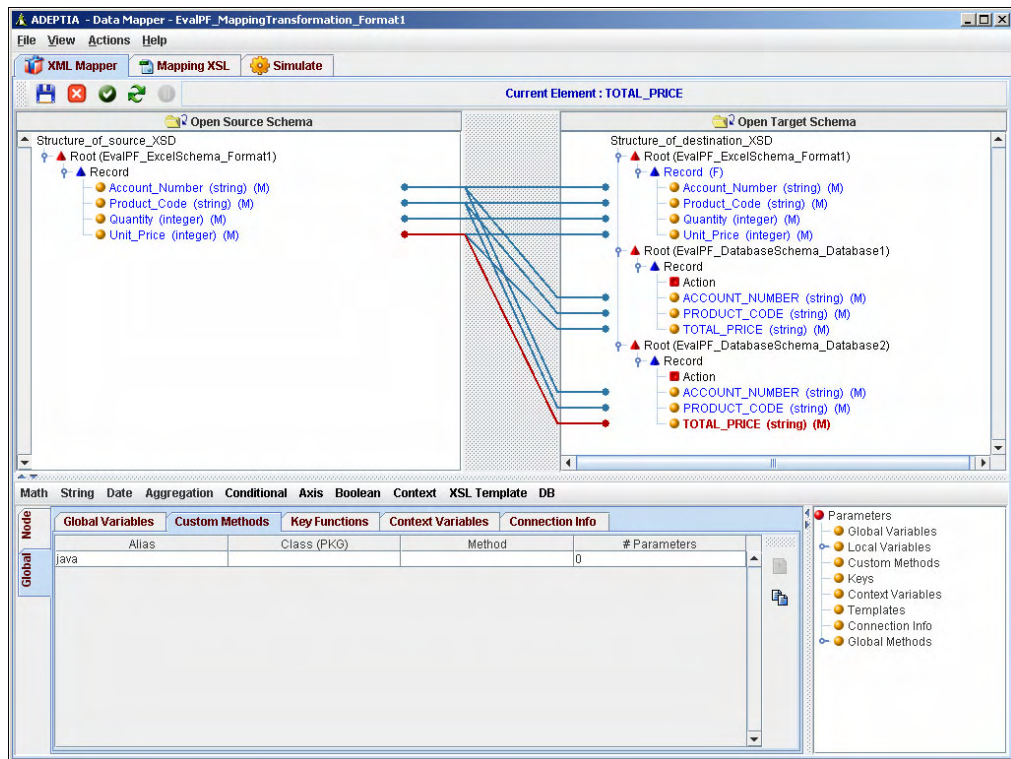



Figure 6.25: Create Custom Method

23. *Alias* column automatically gets populated with value 'java'.
24. Click the *Alias* field, press **[Tab]** or **[Enter]** key to go to the *Class (PKG)* field.
25. Enter the fully qualified name of the Java class (*CustomMethodCall*) in the *Class (PKG)* field.
26. Press the **[Tab]** or **[Enter]** key to go to the *Method* field and enter the name of the method (*getAccountType*) in the *Method* column.

	The Java Method specified here is stored in <code>../serverkernel/CustomClasses</code> folder.
---	--

27. Press the **[Tab]** or **[Enter]** key to go to the *# Parameter* field and enter the number of arguments (1) taken by Method in the *# Parameter* column.
28. Press the **[Tab]** or **[Enter]** key to return to the *Alias* field. This will save the added Custom Method (see Figure 6.26).

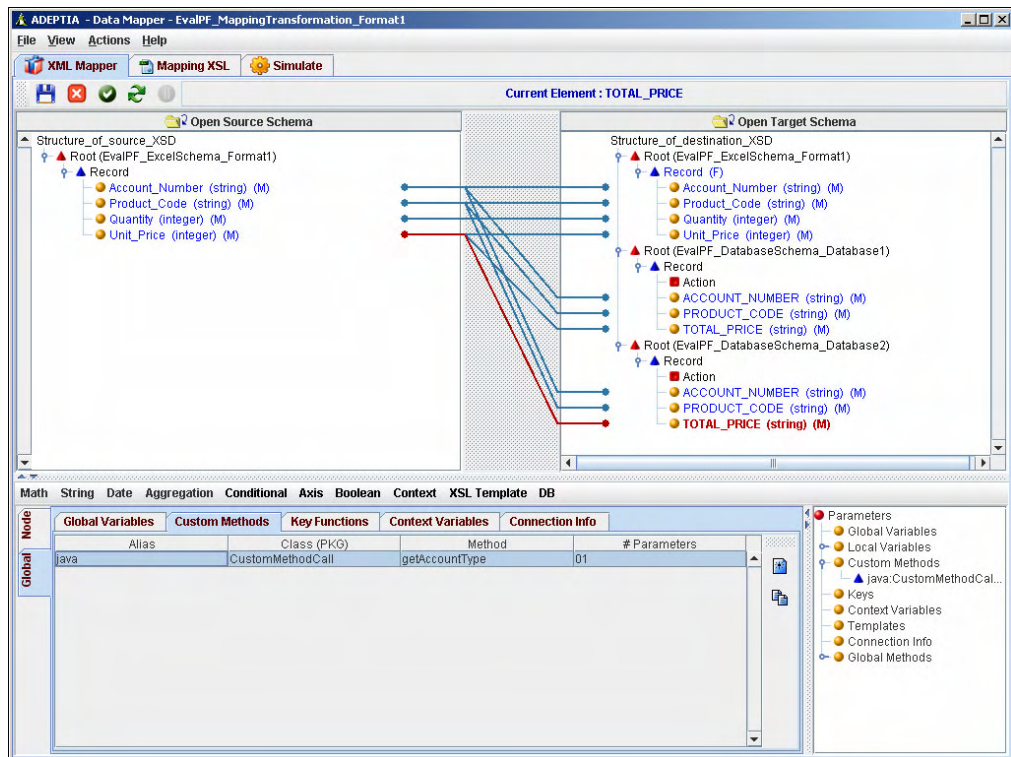



Figure 6.26: Save Custom Method

 The saved custom method is displayed under *Custom Methods* in the Parameters Panel.

29. Click the **Node** tab to map above declared Custom Method to the *Account_Number* node. The Mapping Graph Area is displayed.
30. Select the node **Record** element of first target schema. The *Record* node is shown in the Mapping Graph Area.
31. Double-click the **Account_Number** node in the Source Panel. The *Account_Number* node is shown in the Mapping Graph Area.
32. Expand the *Custom Methods* tree in the Parameters Panel. Double click the defined Custom Method. The selected Custom Method Node is displayed in the Mapping Graph Area (see Figure 6.27).

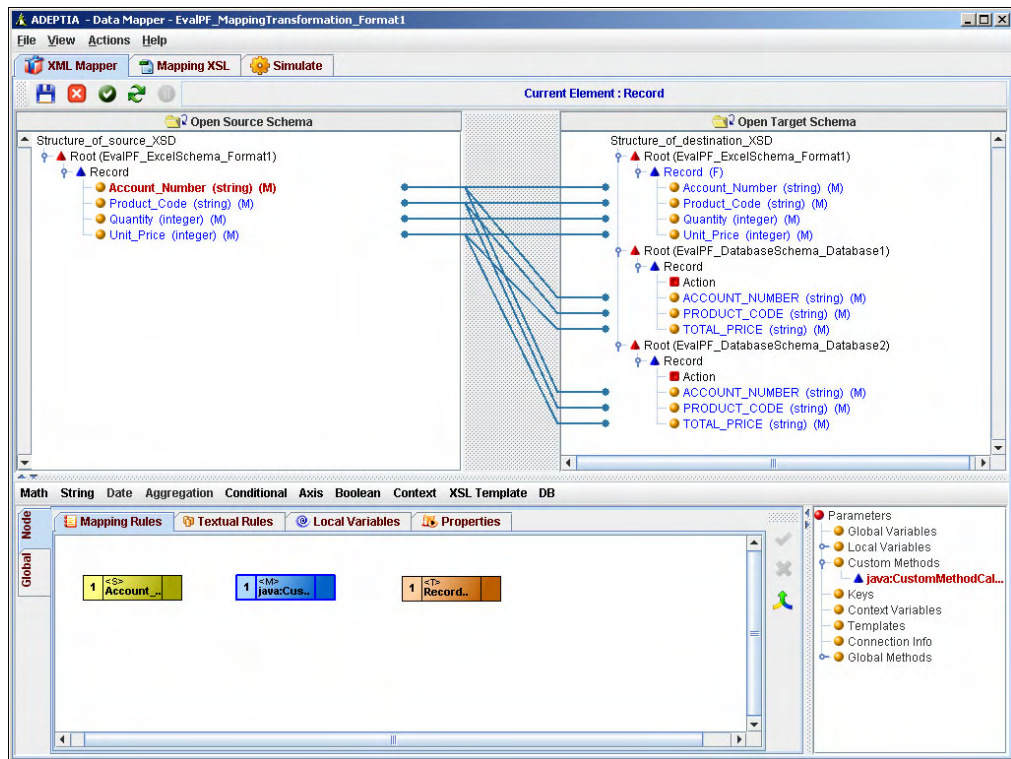

Figure 6.27: Select Custom Method

33. To add the constant value ('*Errordata*'), right-click the blank space in the Mapping Graph area and select the **Constant** option. A *Constant* node is displayed in the Mapping Graph area.
34. Double-click the **Constant** node. The Input dialog box is displayed (refer to Figure 3.41).
35. Enter the required constant value *Errordata* in the *Enter the Value* field.
36. Check the *Add Quotes* checkbox and click the **OK** button. The entered value is shown in the *Constant* node (see Figure 6.28).

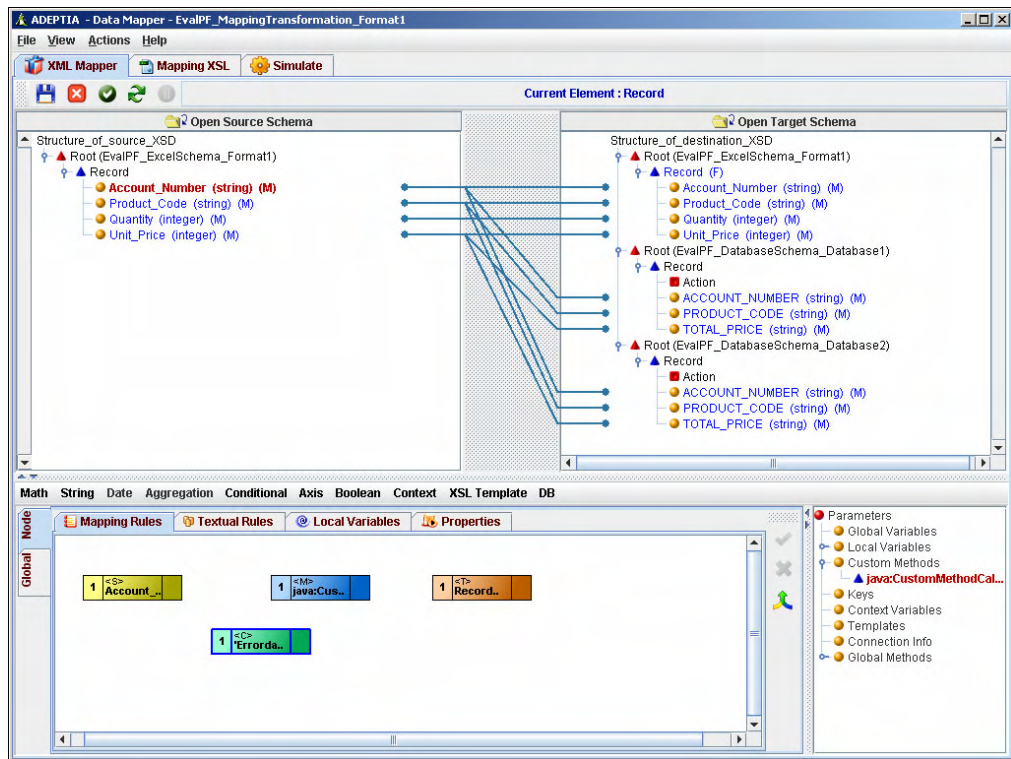

Figure 6.28: Constant Value Entered

37. Click the **Boolean** mapping function and select **Equal** = sub-function. The *Equal* function node is displayed in the Mapping Graph Area.
38. Create a link from the output of the *Account_Number* node to the input of the *Custom Method* node.
39. Create a link from the output of the *Custom Method* node to the first input of the *Equal* function node.
40. Create a link from the output of the *Constant* function node to the second input of the *Equal* function node (see Figure 6.29).

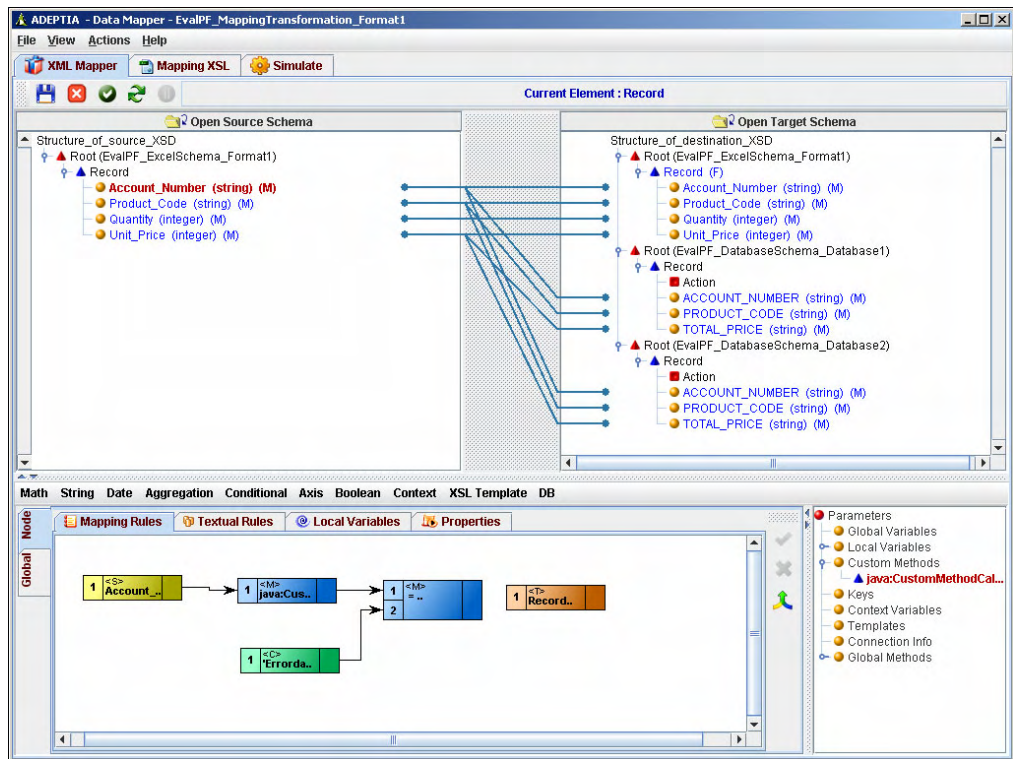



Figure 6.29: Create Links

41. Create another constant node with the value ('True').

	You need to add quotes while adding the value True .
---	---

42. Click the **Conditional** mapping function and select **IF CONDITION > For Filtering Records** sub-function. The *IFF Condition* node is displayed in the Mapping Graph Area (see Figure 6.30).

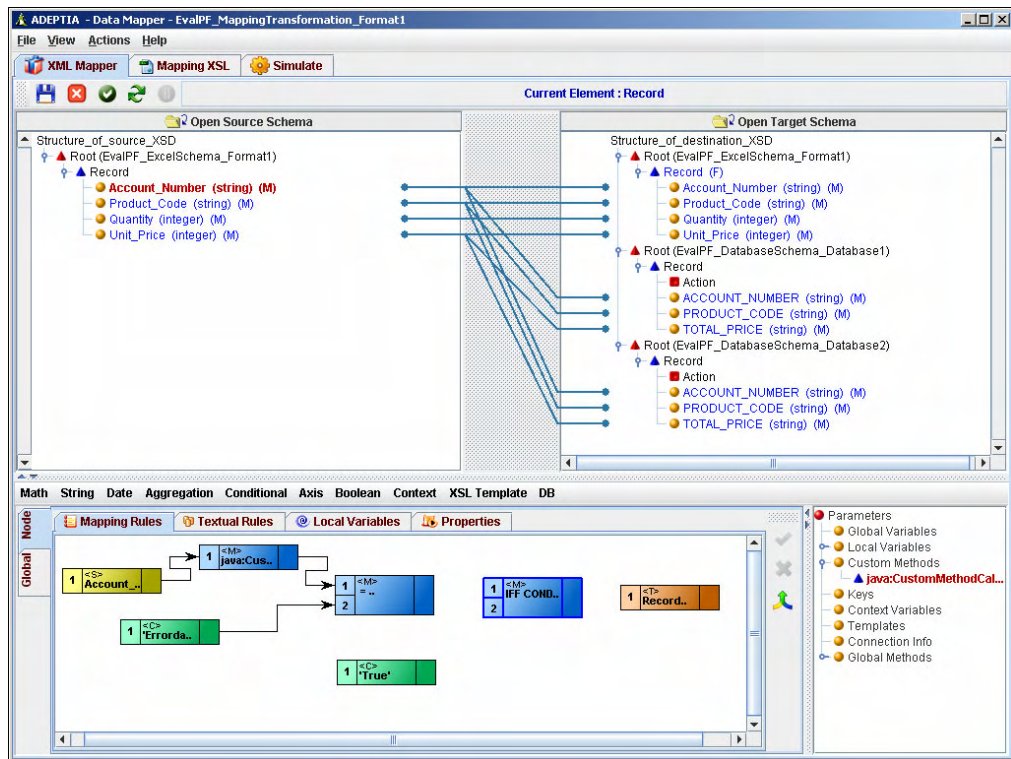

Figure 6.30: Select IF Condition

43. Create a link from the output of the *Equal* function node to the first input of the *IFF Condition* node.
44. Create a link from the output of the *Constant* node ('True') to the second input of the *IFF Condition* node.
45. Create a link from the output of the *IFF Condition* node to the input of the *Record* node.
46. Click the **Apply Mapping** (✓) button to apply the mapping. Lines indicating mapping between the source and target nodes are displayed (see Figure 6.31).

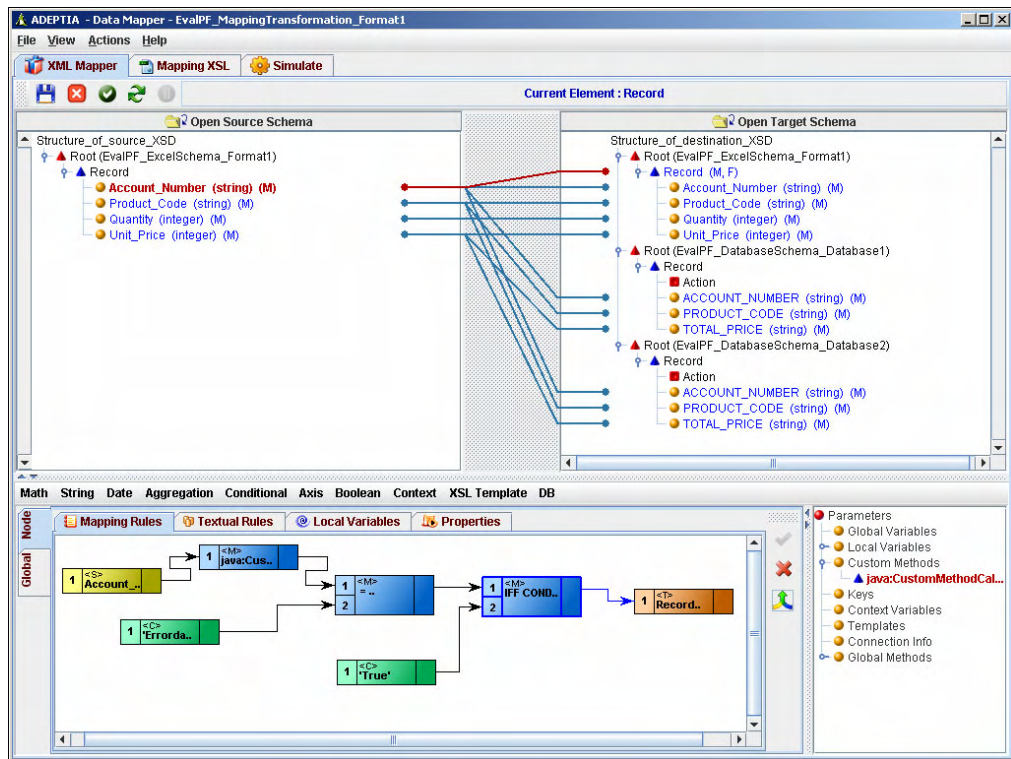



Figure 6.31: Apply Mapping

47. Similarly, to apply Custom Method on second schema (*EvalPF_DatabaseSchema_Database1*), select the **Record** node of the second schema and follow the steps 29 to 45.

 The only difference is that you have to enter *NumericNumeric* as the constant value instead of *ErrorData*.

48. To apply Custom Method on third schema (*EvalPF_DatabaseSchema_Database2*) select the **Record** node of the second schema and follow the steps 29 to 45.

 The only difference is that you have to enter *AlphabetNumeric* as the constant value instead of *ErrorData*.

49. Right-click the **Root** of the second target schema and select **Assign Stream** option. The **Assign Streams** dialog box is displayed (see Figure 6.32).

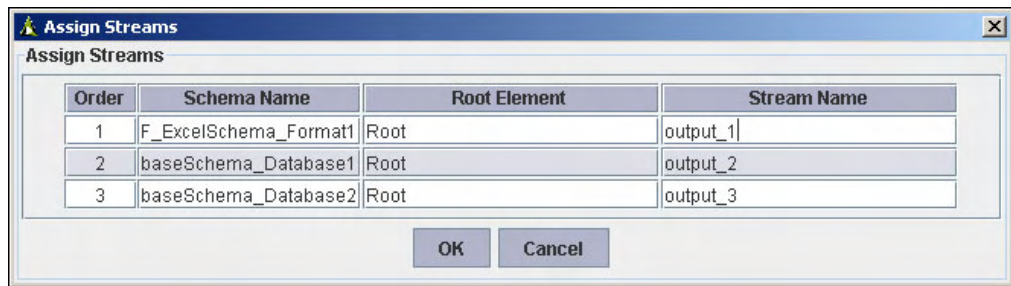

Figure 6.32: Assign Streams

50. Enter any stream name (*default*) for the Root having Occurrence Order 1.
51. Enter any stream name (*database1*) for the Root having Occurrence Order 2.
52. Enter any stream name (*database2*) for the Root having Occurrence Order 3 (see Figure 6.33).

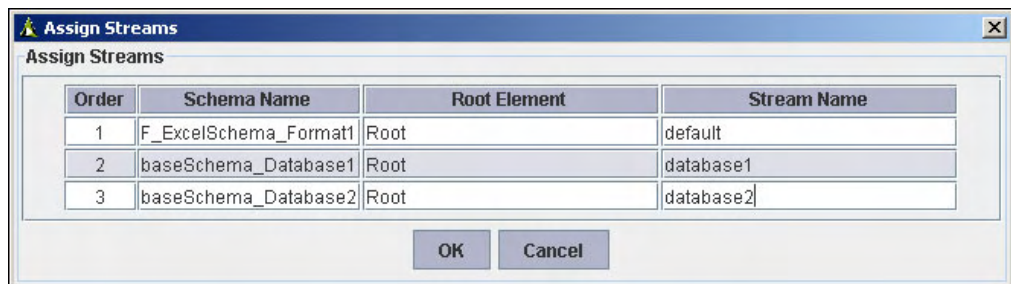

Figure 6.33: Enter Stream Name



The stream for Root having Occurrence Order 1 is not activated in the Assign Stream dialog box because it has default stream assigned to it.

53. Click on **OK** to close the Assign Stream dialog box.
54. Save the mapping by clicking the **File** menu and selecting **Save**. A dialog box is displayed confirming that the mapping activity has been saved successfully.
55. If the *comments* property is enabled, then clicking **Save** will display a screen where you need to enter comments related to the mapping (refer to Figure 7.18).
56. Enter the comments in the *Specify comments for mapping object (object name)* field.



The comment should be at least 1 character in length.

57. Click **OK** to save the comments. This displays a dialog box confirming that the mapping has been saved successfully.
58. Exit the Data Mapper applet by clicking the **File** menu and selecting **Exit**.



CREATING PROCESS FLOW

(EvalPF_ProcessFlow_SalesReport)

Process Flow is the set of activities arranged in a sequence to perform a specific task(s). Process Flow is created by combining various activities i.e. Source, Target, Schema or Transformer etc. Process Designer is used to create Process Flow. Process Designer has list of activities created. You only need to arrange them in a logical sequence and connect them with BPMN Flows.

Steps to create this sample Process Flow:

1. In the Adeptia Suite homepage menu, click **[+] Design** to expand the tree. All the items in the **Design** category are displayed.
2. Click **[+] Process Flow** to expand the tree and then click **Process Flow**. The Manage Process Flow screen is displayed with the list of existing Process Flows (Refer to Figure 7.27).
3. Click the **New Process Flow** button. The Create Process Flow screen is displayed (Refer to Figure 7.28).
4. Enter the name and the description of the new Process Flow in the *Name* and *Description* fields respectively.
5. Select the logging level from the *Logging Level* drop-down list. There are four levels of logging. These are described in Table 7.9.
6. Select repository file retention from the *Repository File Retention* option. During execution Process Flow creates a temporary repository file to store the intermediate data. These repository files can cause unnecessary disk space usage and you may want to delete them after execution of the Process Flow. On the other hand sometime these repository files can be helpful in case of failure of Process Flow execution. . For each instance of the Process Flow execution a unique repository folder is created that contains Source, intermediate XML data files and target formatted data. By default repository files are being stored in the repository folder of the Adeptia Suite. You can also choose an option to delete them or to archive them in a different location. There are four options for the Repository File Retention. These are described in Table 7.10.
7. Click the **Process Designer** button to open Process Designer. The Process Designer Screen is displayed (Refer to Figure 7.29).
8. Once the Process Designer screen is displayed, a message to synchronize the list of activities and Process Flow with the Adeptia Suite is displayed. Click **OK** to synchronize.

	Alternately, you can synchronize the list of activities and Process Flow with the Adeptia Suite by clicking the Synchronize () button displayed on the Tool Bar.
---	--

9. Click **[+]Activities** in Repository View, to expand the list of services and then click **[+] Source**. All the items in the **Source** category are displayed.
10. Click **[+] Mail Source** under **Source** category. A list of existing Mail Source activities is displayed.
11. Select **EvalPF_MailSource** and drag it to the Graph Canvas Area (see Figure 6.34).

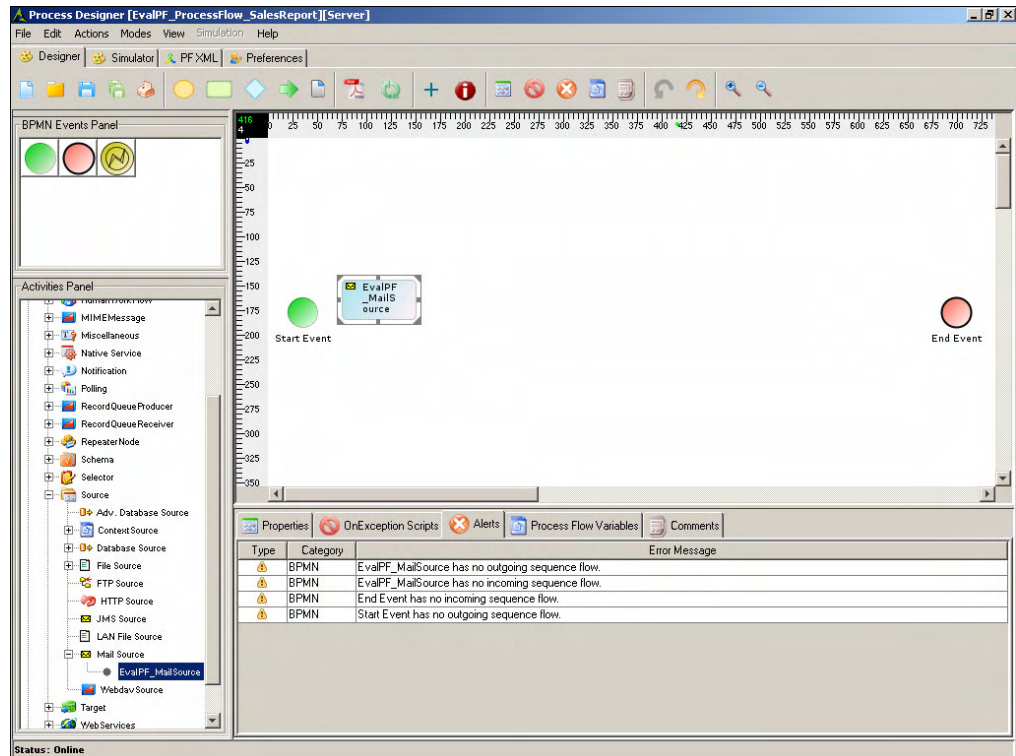

Figure 6.34: Drag File Source Activity to Graph Canvas Area

12. Right click on the *EvalPF_MailSource* activity and select *View Properties*. Properties of the *EvalPF_MailSource* activity are shown in the *Properties* panel of the Bottom Pane.
13. Change the value of *eventContextEnabled* property from *false* to *true*.
14. To select a BPMN Gateway, click the **Gateway** () icon in the Palette and drag it to the Graph Canvas Area (see Figure 6.35). In this Process Flow, **Gateway** is used to check the subject of the incoming mail and to decide which schema is to be used.



Figure 6.35: Drag BPMN Gateway Element to Graph Canvas Area

15. Click **[+] Schema** in the Activities Panel, and then click **[+] Excel Schema**. Select **EvalPF_ExcelSchema_Format1** activity and drag it to the Graph Canvas Area.
16. Similarly, drag **EvalPF_ExcelSchema_Format2** activity to the Graph Canvas Area.
17. Similarly, click **[+] DataTransform** and then **[+] Data Mapping**. Select **EvalPF_MappingTransformation_Format1** activity and drag it to the Graph Canvas Area.
18. Select **EvalPF_MappingTransformation_Format2** activity and drag it to the Graph Canvas Area.
19. After these activities are dragged to the Graph Canvas Area, they must be connected using appropriate BPMN Flows or Control Flows.
20. Click the **Sequence Flow** (→) icon in the Palette. The Sequence flow is selected.
21. To connect *Start Event* with *EvalPF_MailSource*, drag mouse pointer from *Start Event* to *EvalPF_MailSource* (see Figure 6.36).

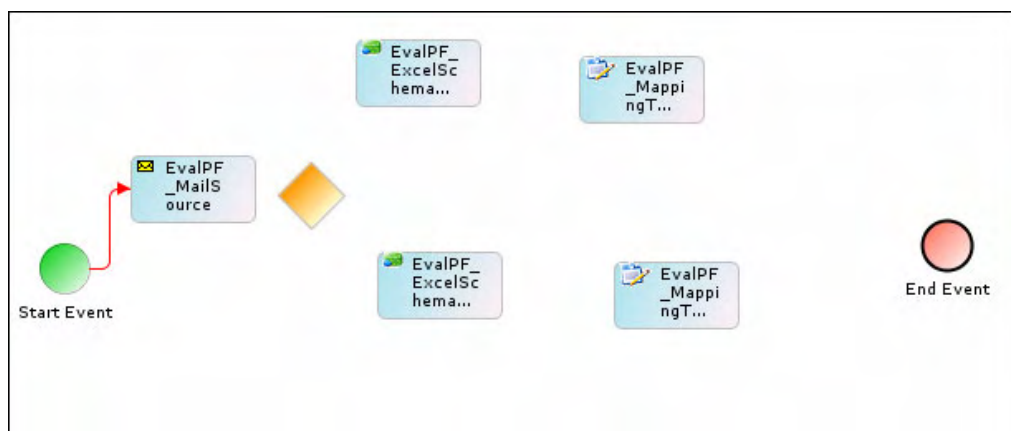

Figure 6.36: Connect Start Event to File Source Activity

22. Similarly, connect all other activities (see Figure 6.37).

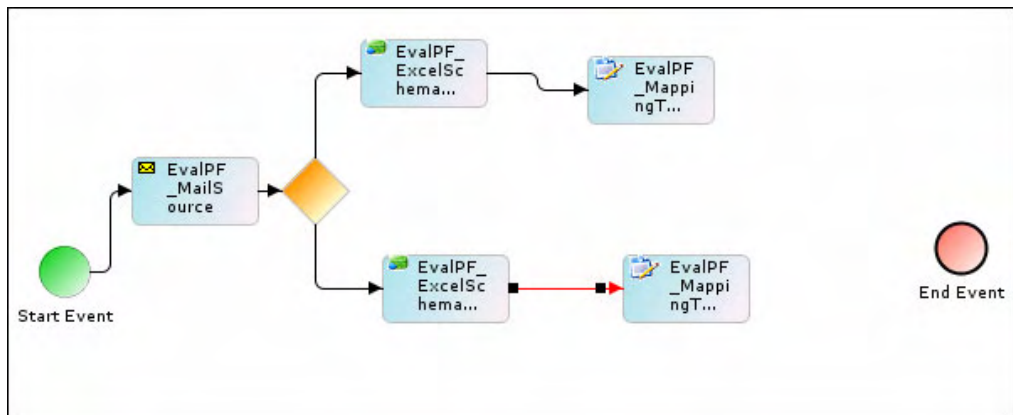
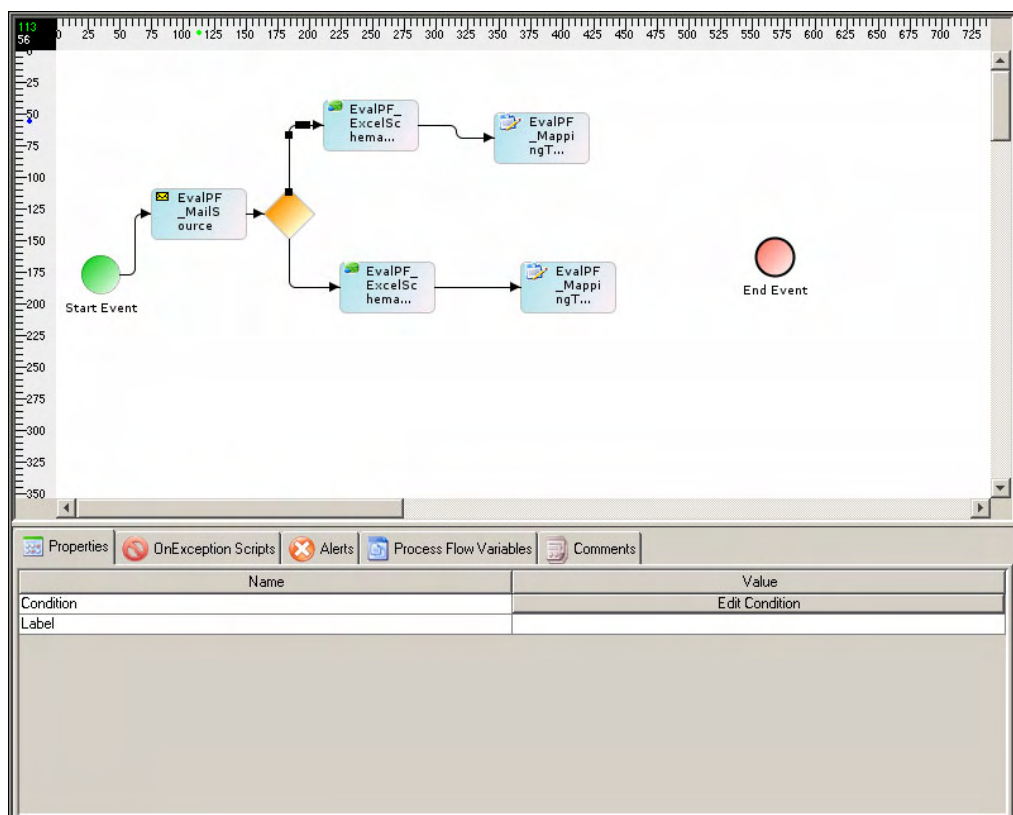

Figure 6.37: Connect all Activities

23. After connecting these activities, you need to define decision criteria on the BPMN Gateway. To define the decision criteria, right-click the BPMN Flow which is connecting *Gateway* and *EvalPF_ExcelSchema_Format1* activity and select **View Properties** (see Figure 6.38).



Properties	
Name	Value
Condition	Edit Condition
Label	

Figure 6.38: Define Decision Criteria

24. Click **Edit Condition** in the Properties Panel. The Condition Wizard is displayed (Refer to Figure 8.30).
25. Select **Process Flow Variable Condition** and click the **Next** button. The Process Flow Variable Condition type screen is displayed (see Figure 6.39).

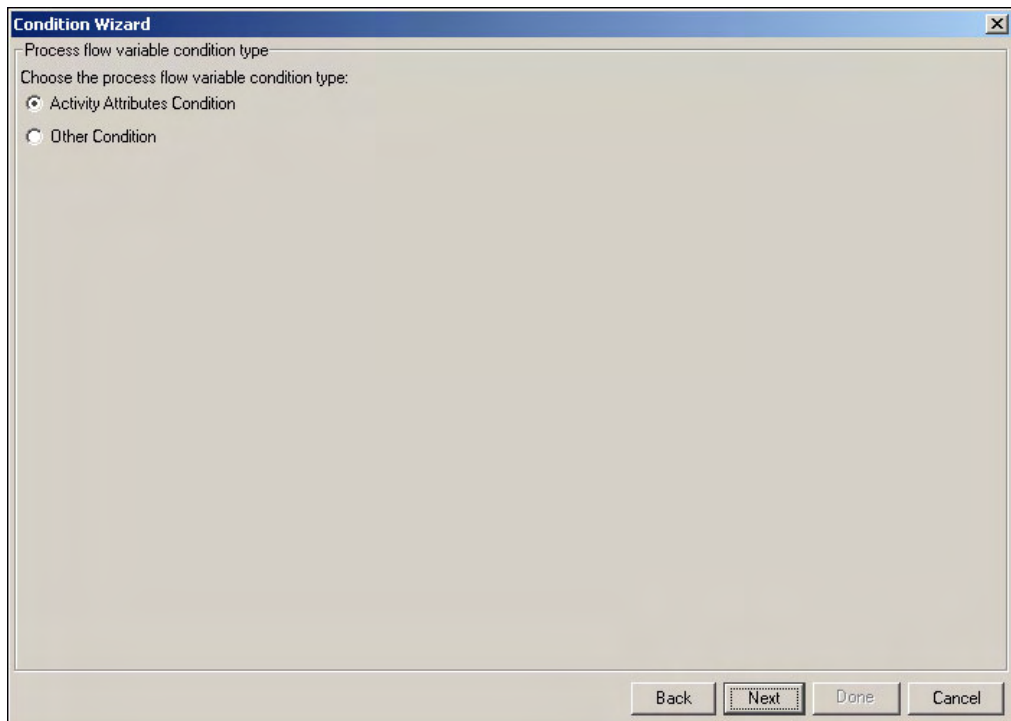

Figure 6.39: Process Flow Variable Condition Type

26. Select **Activity Attributes Condition** and click the **Next** button. The Activity Attribute Condition screen is displayed (see Figure 6.40).

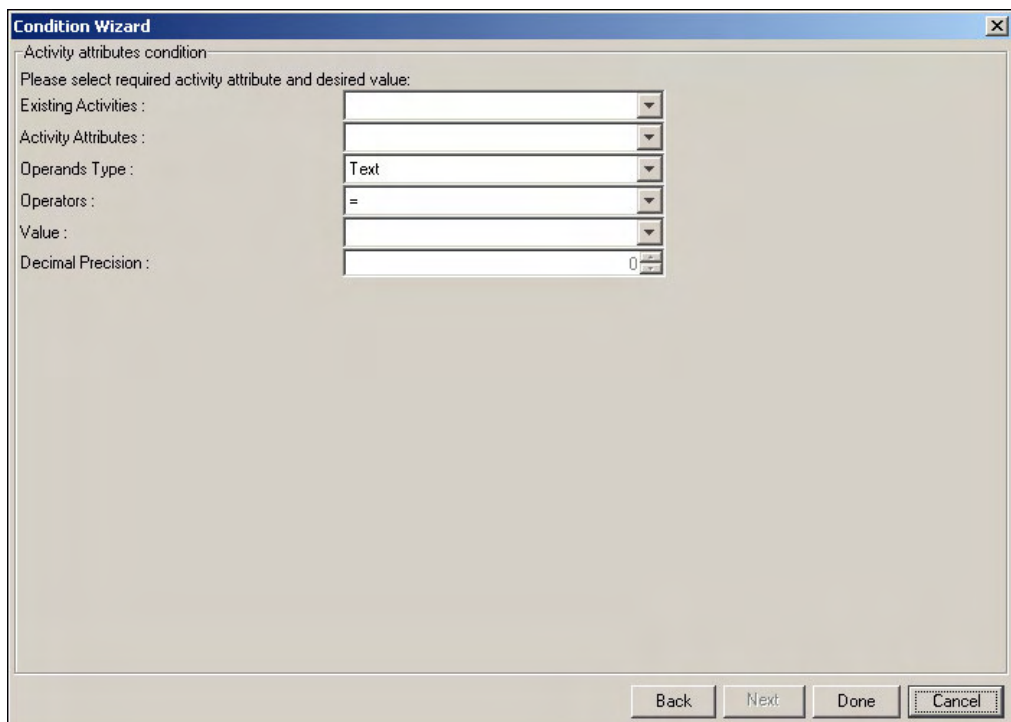
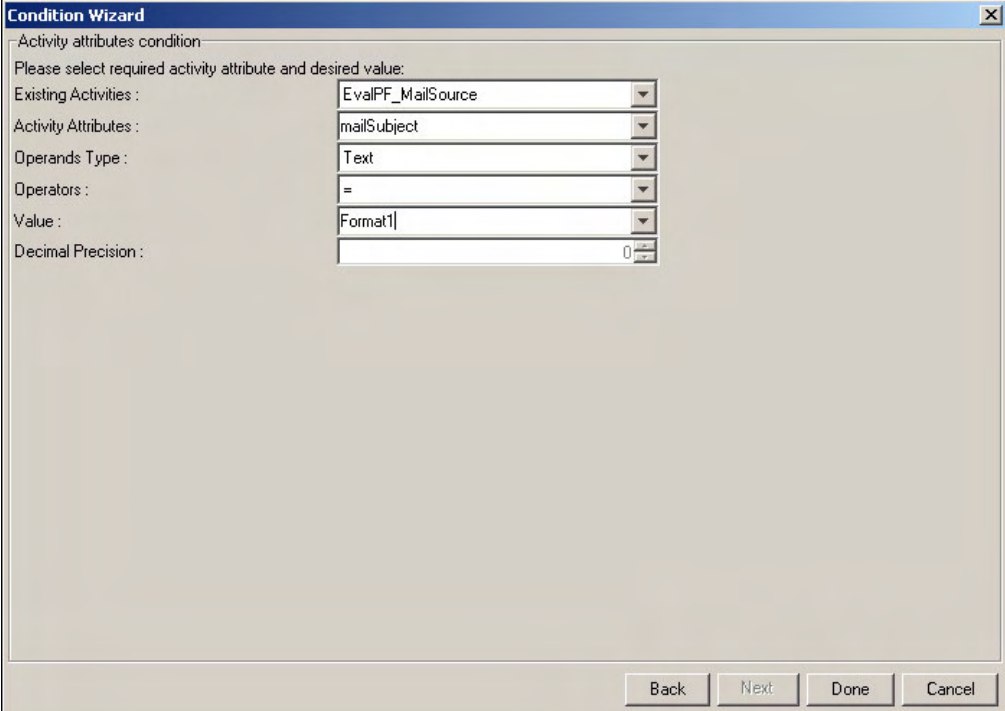

Figure 6.40: Select Activity Attributes

27. Select **EvalPF_MailSource** from the *Existing Activities* drop-down list, and select **mailSubject** from *Activity Attributes* drop-down list.
28. Select **Text** from the *Operand Type* drop-down list, and select = from the *Operators* drop-down list.
29. Enter *Format1* in the *Value* field (see Figure 6.41).



Condition Wizard

Activity attributes condition

Please select required activity attribute and desired value:

Existing Activities : EvalPF_MailSource

Activity Attributes : mailSubject

Operands Type : Text

Operators : =

Value : Format1

Decimal Precision : 0

Back Next Done Cancel

Figure 6.41: Select Attribute Value for *Format1*

30. Click the **Done** button to close the **Condition Wizard**.
31. Similarly, right-click the **BPMN Flow**, which is connecting *Gateway* and *EvalPF_ExcelSchema_Format2* activity and select **View Properties**.
32. Repeat the steps 26 to 30 and enter *Format2* in *Value* field (see Figure 6.42).

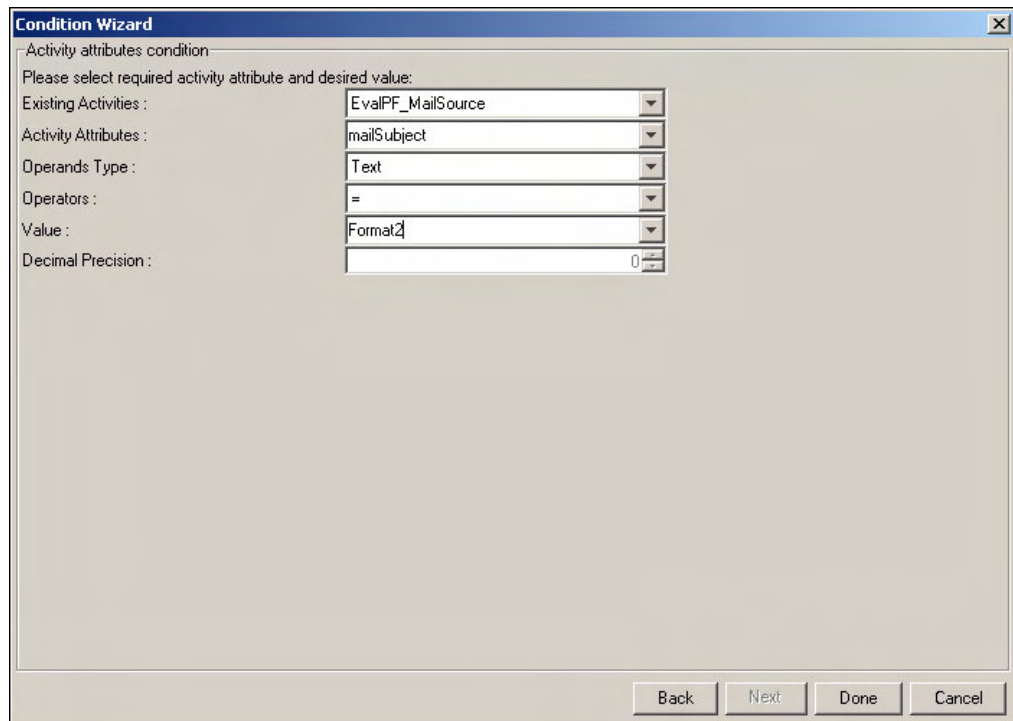
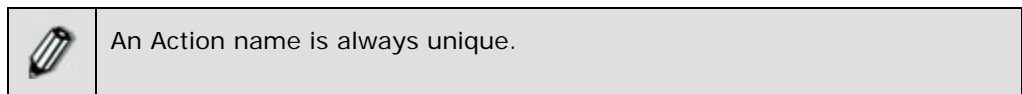

Figure 6.42: Select Activity Attributes for Format2

33. Click the **Done** button to close the Condition Wizard.
34. Click **[+] Target** and then **[+] File Target**. Select **EvalPF_FileTarget_ErrorRecord** activity and drag it to the Graph Canvas Area.
35. Click **[+] Action** in the Repository View to expand the list of Actions.



36. Select **Put-Context-Var** and drag it to the Graph Canvas Area and change its *label* to **Seq1_File_Path** (see Figure 6.43).

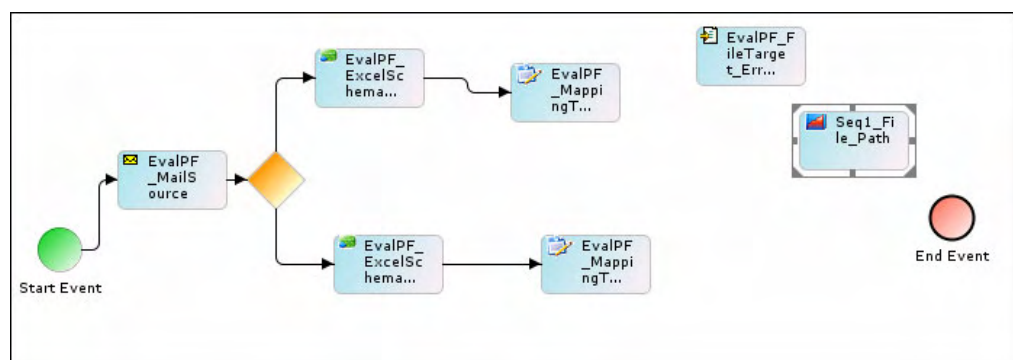

Figure 6.43: Drag *Put-Context-Var* to Graph Canvas Area

37. Connect **EvalPF_MappingTransformation_Format1** with **Seq1_File_Path** and then **Seq1_File_Path** with **EvalPF_FileTargetErrorRecord** (see Figure 6.44).

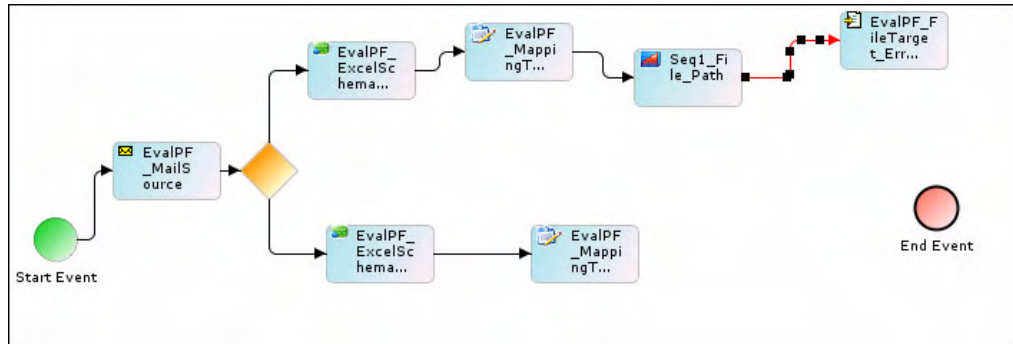
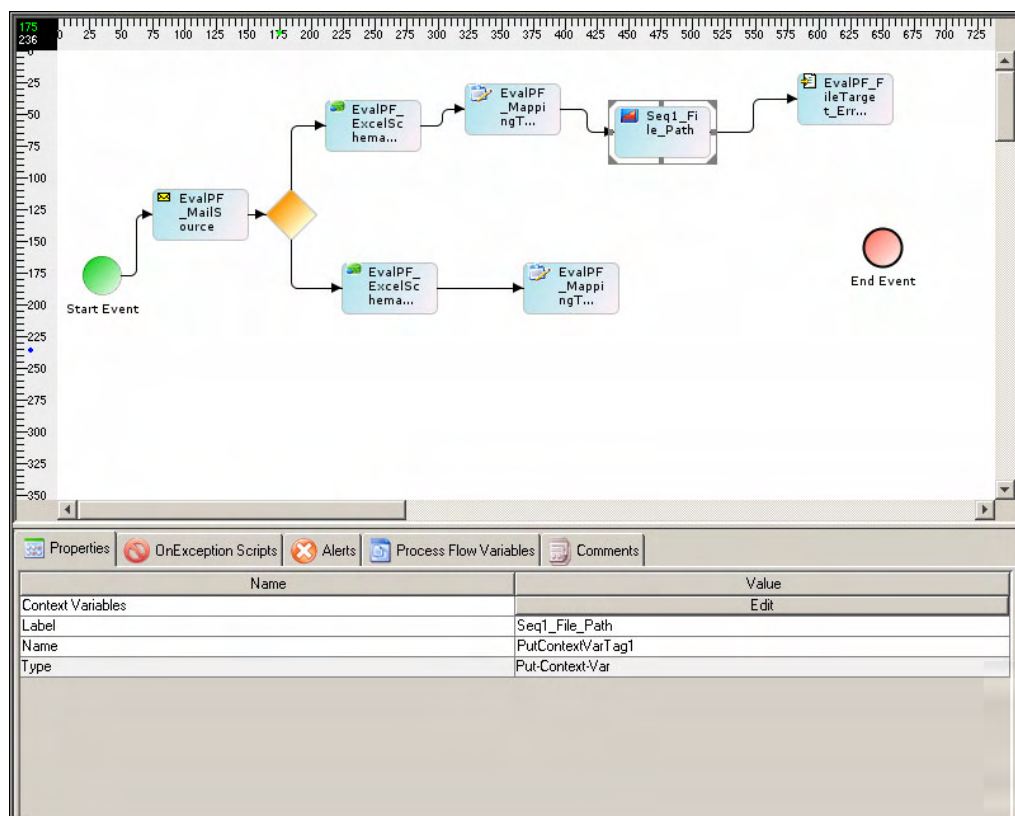

Figure 6.44: Connect Activities

38. In Graph Canvas Area, right-click **Seq1_File_Path** and select **View Properties**. Properties of **Seq1_File_Path** are shown in the Properties Panel (see Figure 6.45).



Name	Value
Context Variables	
Label	Seq1_File_Path
Name	PutContextVarTag1
Type	Put-Context-Var

Figure 6.45: View Properties of *Seq_File_Path*

39. Click *Edit* from the *value* column of the *Context Variable* property. The *Edit Context Variables* screen is displayed (see Figure 6.46).

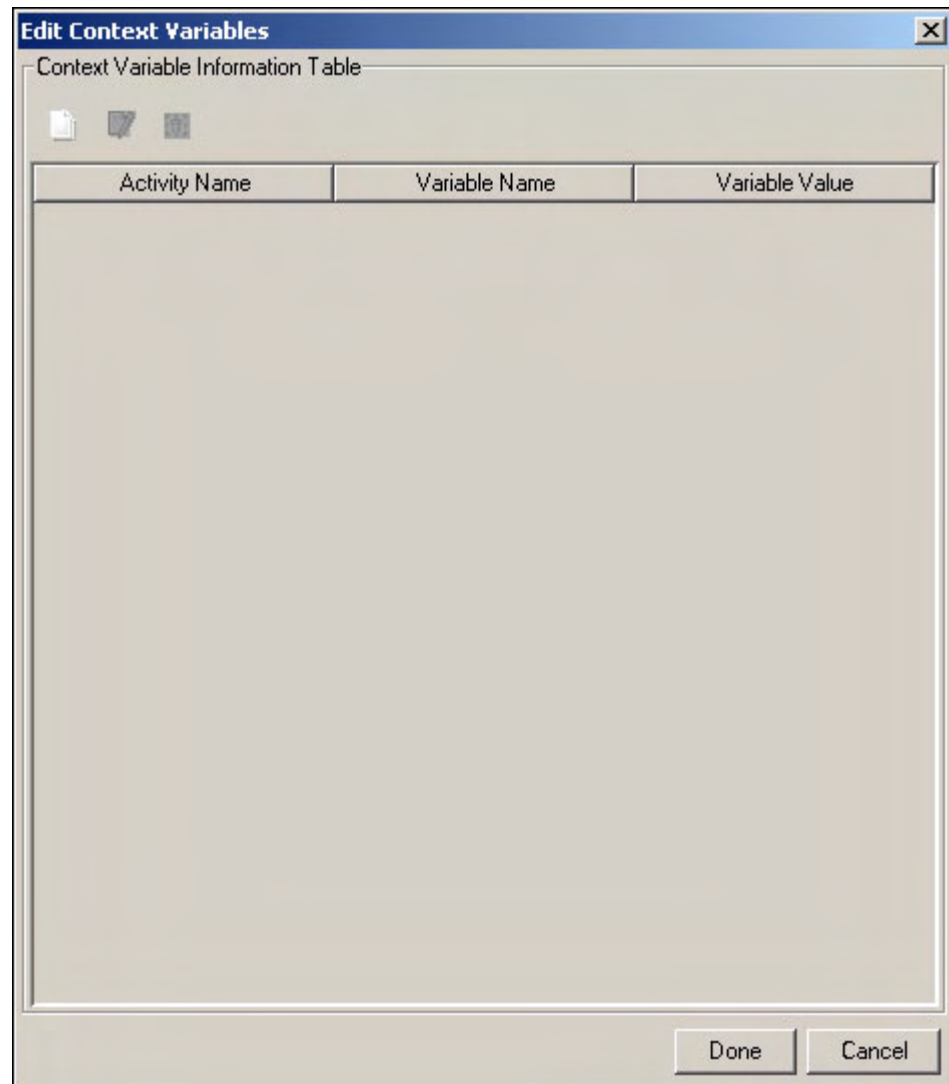



Figure 6.46: Edit Context Variable

40. Click *New Context Variable* () button. The *Context Variable Information* dialog box is displayed (see Figure 6.47).

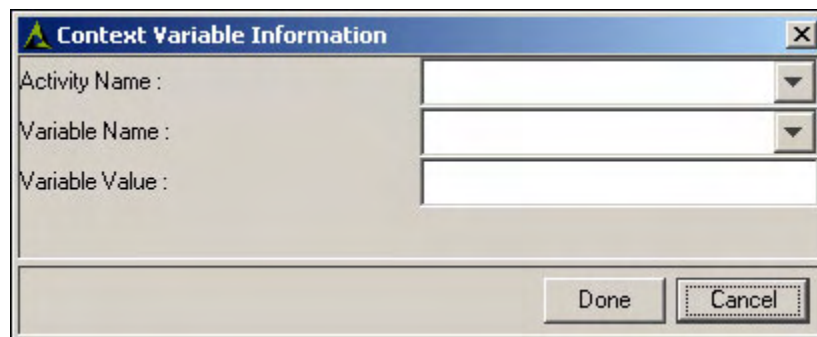

Figure 6.47: Add Context Variable

41. Select *EvalPF_FileTarget_ErrorRecord* from the *Activity Name* drop-down list.
42. Select *filepath* from the *Variable Name* drop-down list.
43. Enter the path of the target file with date and time format in the *Variable Value* field.
 For example `../../Solutions/Demo/EvalPF/ErrorRecord -%%yyyy-mm-dd%% %%hh-mm-ss%%.txt`
44. If the target file is saved on 2005-02-05 at 06-30-35, name of the file will be *ErrorRecords-2005-02-05-06-30-35.txt*
45. Click **[+] Target** and then **[+] Database Target**. Select **EvalPF_DatabaseTarget_Database1** activity and drag it to the Graph Canvas Area.
46. Similarly, drag **EvalPF_DatabaseTarget_Database2** activity to the Graph Canvas Area.
47. Connect these activities as shown in Figure 6.48.

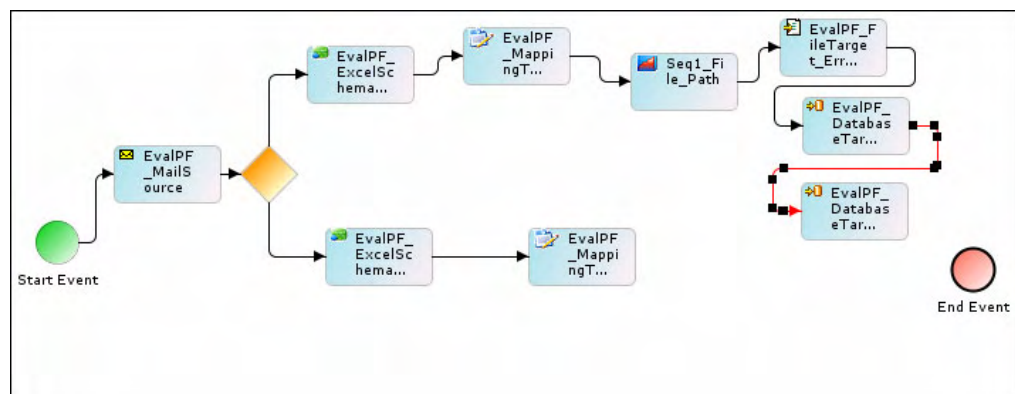

Figure 6.48: Connect Activities

48. Click **[+] Target** and then **[+] File Target**. Select **EvalPF_FileTarget_InsertError** activity and drag it to the Graph Canvas Area.
49. Similarly, drag **EvalPF_FileTarget_UpdateError** activity to the Graph Canvas Area.
50. Click **Action** and drag the **Put-Context-Var** action in the Graph Canvas Area (see Figure 6.49).
51. Right-click it and change the properties as shown in the table below.

Table 6.13: Changed Properties

Properties	Value
Label	Seq2_File_Path
Activity	EvalPF_FileTarget_InsertError
Variable Name	filepath
Variable Value	../../Solutions/Demo/EvalPF/InsertError - %%yyyy-mm-dd%% %%hh-mm-ss%%.txt

52. From the Activities Panel, again drag the **Put-Context-Var** action in the Graph Canvas Area. Right-click it and change the properties as shown in the table below.

Table 6.14: Changed Properties

Properties	Value
Label	Seq3_File_Path
Activity	EvalPF_FileTarget_UpdateError
Variable Name	filePath
Variable Value	../../../../Solutions/Demo/EvalPF/UpdateError-%yyyy-mm-dd% %hh-mm-ss%.txt

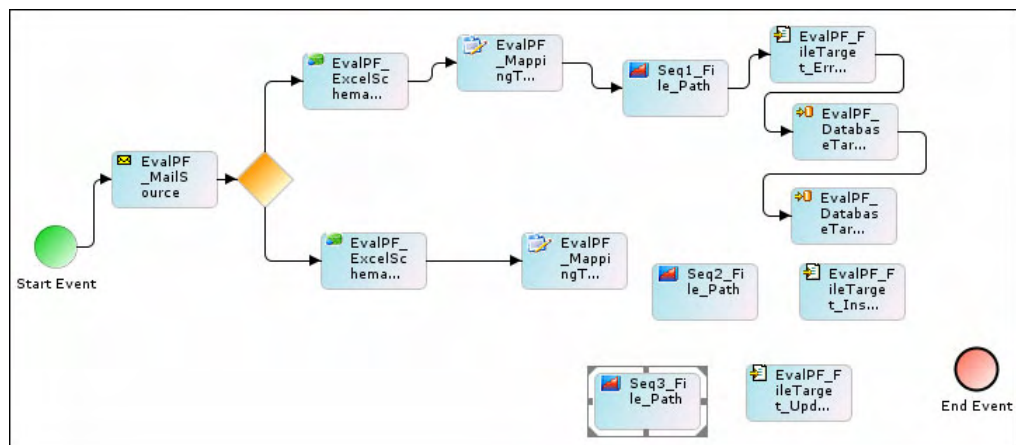

Figure 6.49: Drag *Put-Context-Var* to Graph Canvas Area

53. Connect these activities as shown in the Figure 6.50.

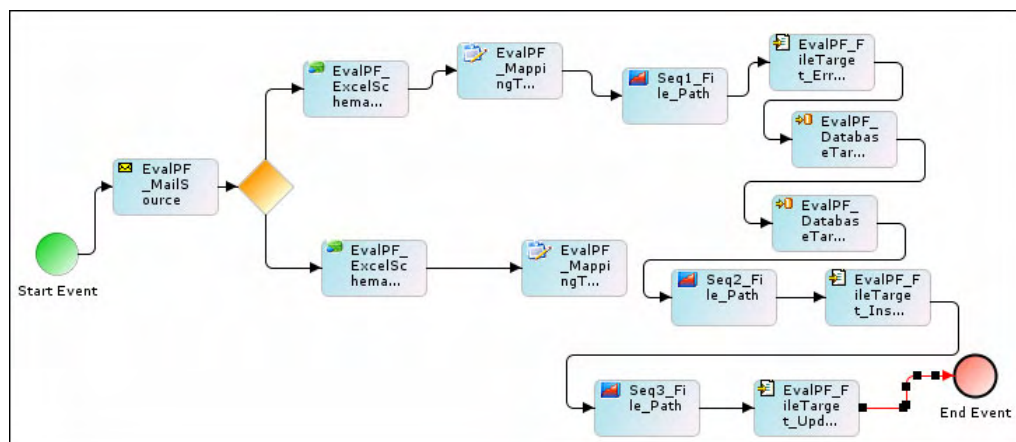

Figure 6.50: Connect Activities

54. Repeat the steps 36 to 55 to make another sequence of activities from **EvalPF_MappingTransformation_Format2** (see Figure 6.51).

56. Enter any name for the Data Stream (default) in the *Stream Name* field and click **Add Stream**.
57. Ensure that **EvalPF_ExcelSchema_Format1** is selected in the *Activities* drop-down list.
58. Click the **Map** button. A stream between **EvalPF_MailSource** and **EvalPF_ExcelSchema_Format1** is created.
59. Make sure the *Explicit Stream* checkbox is checked. A stream between **EvalPF_MailSource** and **EvalPF_ExcelSchema_Format1** is created.
60. To create another stream, click the *Activities* drop-down list and select **EvalPF_ExcelSchema_Format2** and then click the **Map** button. A dialog box is displayed (Refer to Figure 5.23).
61. Click the **Yes** button. Another stream between **EvalPF_MailSource** and **EvalPF_ExcelSchema_Format2** is created.
62. Click the **Done** button to close the Multiple Stream Dialog box. Streams created are shown in the Graph Canvas area (see Figure 6.52).

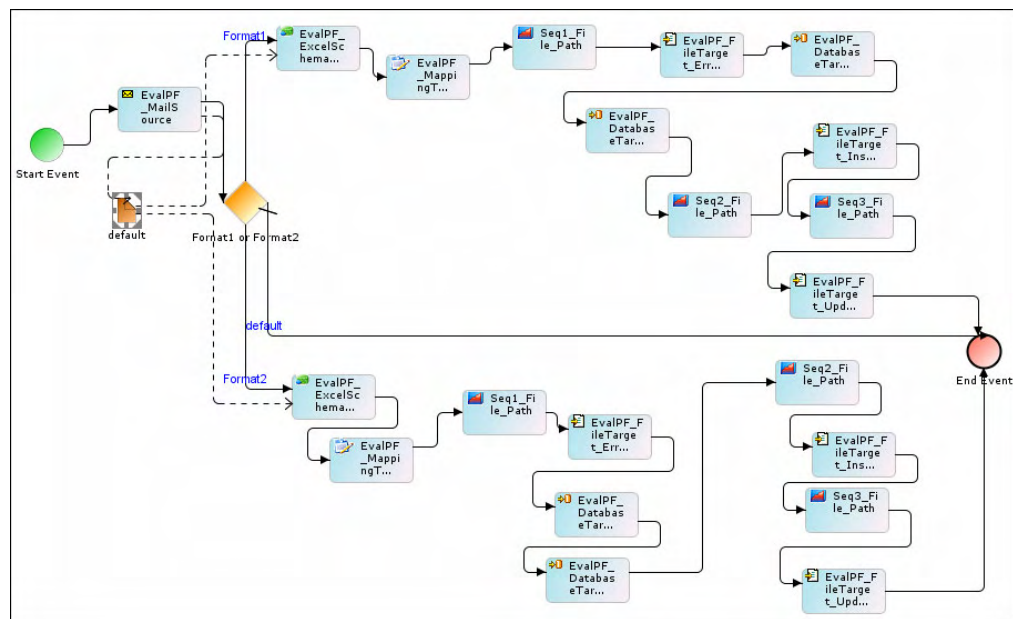



Figure 6.52: Multiple Streams Created

63. Repeat steps 57 to 64 to create another streams between activities listed below (see Figure 6.53):
 - From EvalPF_Mapping_Format1 to EvalPF_FileTarget_ErrorRecord, EvalPF_DatabaseTarget_Database1 and EvalPF_DatabaseTarget_Database2
 - From EvalPF_Mapping_Format2 to EvalPF_FileTarget_ErrorRecord, EvalPF_DatabaseTarget_Database1 and EvalPF_DatabaseTarget_Database2
 - From EvalPF_DatabaseTarget_Database1 to EvalPF_FileTarget_InsertError

- From EvalPF_DatabaseTarget_Database2 to EvalPF_FileTarget_UpdateError



Streams between following activities must be selected as *Error Stream*.

- EvalPF_DatabaseTarget_Database1 and EvalPF_FileTarget_InsertError
- EvalPF_DatabaseTarget_Database2 and EvalPF_FileTarget_UpdateError

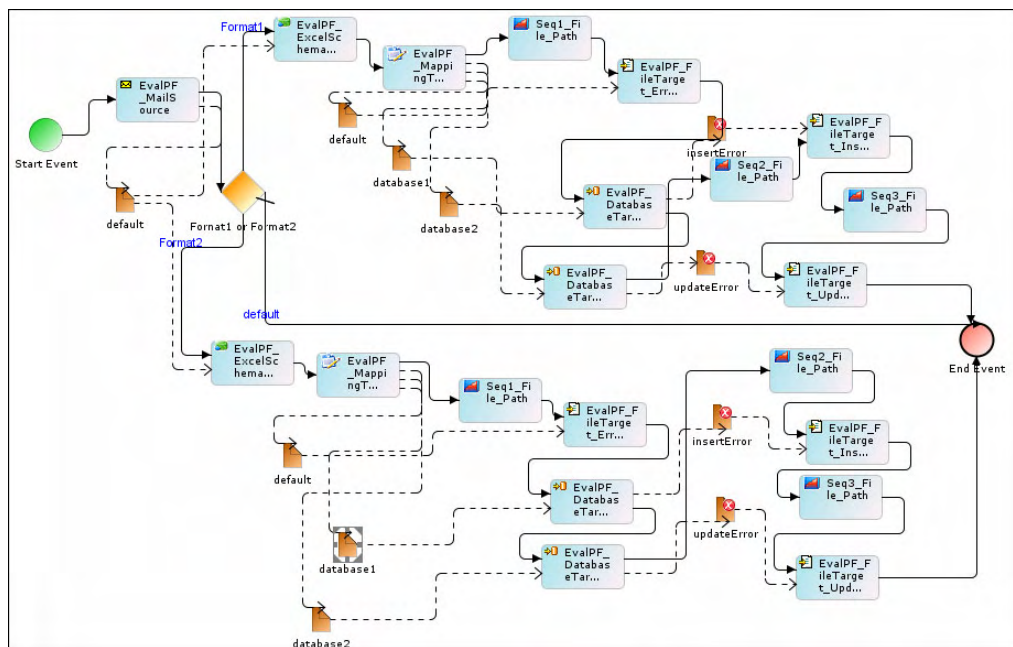

Figure 6.53: Multiple Streams Created for Multiple Activities

64. Save the Process Flow by clicking the **File** menu and selecting **Save Process Flow to Server**. A dialog box is displayed confirming that the *EvalPF_ProcessFlow_SalesReport* has been saved successfully.
65. Click the **Done** button to close the dialog box.
66. Exit the Process Designer by clicking the **File** menu and selecting **Exit**.

REGISTERING PROCESS FLOW WITH MAIL EVENTS

After the Process Flow is created it must be registered with both of the Mail Events. Mail Event triggers the Process Flow when a mail with specified subject arrives on mail server. To register the Process Flow with the Mail Event, Event Registry activity is created. Event Registry (*EvalPF_EventRegistry_Format1* and *EvalPF_EventRegistry_Format2*) used to trigger *EvalJMSE_ProcessFlow_SalesReport* are already created. This section describes how to edit Event Registry.

Steps to edit the Event Registry:

1. In the Adeptia Suite homepage menu, click **[+] Deploy** to expand the tree. All the items in the **Deploy** category are displayed.
2. Click **[+] Events & Triggers** to expand the tree and then click **Event Registry**. The Manage Event Registry screen is displayed with the list of existing Event Registries (Refer to Figure 7.38).
3. Click **Edit** in the **Action** column of the *EvalPF_EventRegistry_Format1* activity. This displays the Edit *EvalPF_EventRegistry_Format1* activity screen, with the properties of the activity displayed in their respective fields (see Figure 6.54).

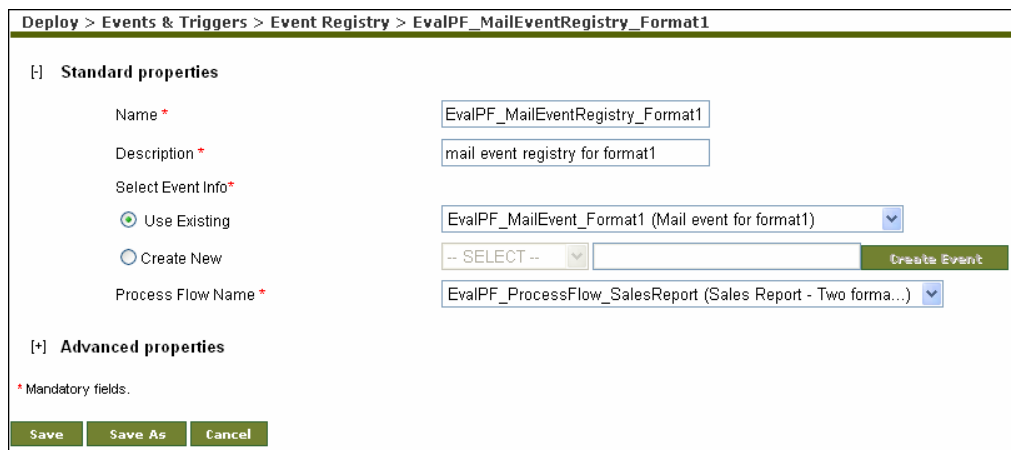



Figure 6.54: Edit *EvalPF_MailEventRegistry_Format1* Activity

A detailed description of fields on this screen is explicated in the table below.

Table 6.15: Details of Fields on Edit Event Registry Screen

Field Name	Field Description
Name	Name of the Event Registry
Description	Description of the Event Registry
Event Name	Name of the JMS Event, which triggers the Process Flow
Process Flow Name	Name of the Process Flow, which is triggered by JMS Event

4. Make the necessary changes.
5. Once you have made the required changes, click the **Save** button to save the changes. A screen is displayed confirming that the Event Registry has been updated successfully. If the *comments* property is enabled, then clicking **Save** will display a screen where you need to enter comments related to updating the event registry (refer to Figure 7.10).
6. Enter the comments in the *Add Comments* field.

The comment should be at least 1 character in length.

7. Click **OK** to save the comments. This displays a screen confirming that the event registry has been updated successfully.

	Repeat the same steps to register the Process Flow with <i>EvalPF_EventRegistry_Format2</i> .
---	---

7 JMS EVENT DRIVEN PROCESS FLOW

This section describes the JMS Event Driven Process Flow.

In the Adeptia Suite this process flow is available in:

BPM Suite	Workflow Suite	Integration Suite	ETL Suite
√		√	√

INTRODUCTION

This sample Process Flow demonstrates the use of a JMS Event for triggering a Process Flow. The JMS Event is configured to listen for the data (containing real-time stock quotes) from a JMS server. The JMS Event is registered with the Process Flow. JMS Event on receiving the data, gets fired, and in turn triggers the Process Flow. The Process Flow receives data from the JMS Event, converts it into database specific format and finally inserts the data into a database server.

SERVICES USED IN THIS SAMPLE PROCESS FLOW

This sample Process Flow illustrates the use of following services of Adeptia Suite:

- JMS Event to trigger a Process Flow.
- Context Source to receive data from the JMS Event.
- Text Schema to parse the data (coming from JMS Server) and to convert it into an intermediate XML format.
- Mapping to map the data fields of the text schema and the database schema.
- Database Schema to convert the data from intermediate XML format into the database specific format.
- Database Driver and Database Info.
- Database Target

DESCRIPTION

This sample Process Flow consists of three components (see Figure 7.1):

- JMS Event to trigger the Process Flow
- Event Registry to register the Process Flow with the JMS Event

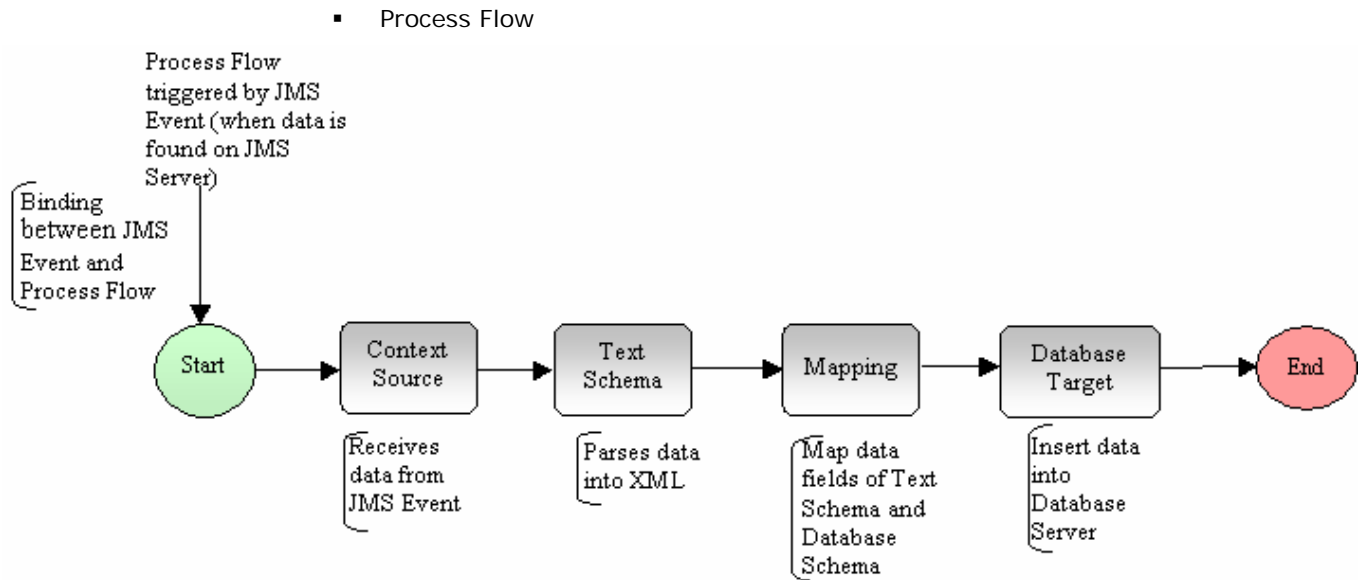

Figure 7.1: Flow Chart showing JMS Driven Process Flow

JMS Event (EvalJMSE_JMSEvent)

JMS event is used to listen for the data on a JMS Queue. The moment JMS Event receives the data; it triggers the Process Flow and passes the data (received from the JMS server containing stock quotes) to context source. JMS Event uses JMS Provider (EvalJMSE_JMSProvider) to connect to JMS Server.

Event Registry (EvalJMSE_EventRegistry)

Event Registry is used to register the JMS Event with the Process Flow. In other words, Event Registry is a link between the JMS Event and the Process Flow.

Process Flow (EvalJMSE_ProcessFlow)

Process Flow receives data from the JMS Event and converts it into database specific format, which is stored in a database server. Process Flow does this conversion using following activities:

- **Context Source** (EvalJMSE_ContextSource)

JMS Event cannot pass the data to the Process Flow and, hence, cannot be used as a source of the Process Flow. The JMS Event sets the data to a Process Flow Variable. To convert the value of the Process Variable into data stream, which is to be consumed by Text Schema, context source is used.

- **Text Schema** (EvalJMSE_TextSchema)

Text Schema is used to parse the data received from the JMS Server and to convert it into an intermediate XML format.

- **Mapping** (EvalJMSE_Mapping)

Mapping is used to map the data fields of Text Schema to the data fields of the Database Schema. In this Process Flow simple one to one mapping is used.

- **Database Driver** (*SQLServerJTDSDriver*)

Database Driver is used to specify the type of database and to upload driver jar files required to connect to that database.

- **Database Info** (EvalJMSE_DBInfo)

Database Info activity is used to specify the JDBC URL or Server URL and Username and Password to access the database. Database Info uses Database driver to connect to the specified Database Server.

- **Database Schema** (EvalJMSE_DBSchema)

At the target end, database Schema is used to convert data from intermediate XML format to database specific format. Database Schema uses Database Driver (*SQLServerJTDSDriver*) and Database Info (EvalJMSE_DBInfo) to connect to Database Server.

- **Database Target** (EvalJMSE_DBTarget)

Database target is used to specify the database server and name of the database, where the target data is to be stored. Database Target uses Database Schema (EvalJMSE_DbSchema).

USAGE SCENARIO

This sample Process Flow can be used whenever you wish to automate the execution of a Process Flow through JMS Event.

DATA DESCRIPTION

The Stock Quote Data contains real-time stock updates for several companies.

Data contains:

- One record per stock
- Records are separated by new line
- Fields under a record are separated by Comma (,)

The structure of the Stock Quote Data is displayed in the table below.

Table 7.1: Structure of Stock Quote Data

Field Name	Description	Data Type
------------	-------------	-----------

Symbol	A unique symbol is assigned to a security	String
CompanyName	Name of the company	String
LastTradePrice	Last trade price	Number
TradeTime	The date and time on which a security trade occurs	Date
PreviousClosePrice	The final price at which a security is traded on a given trading time	Number
OpenPrice	Start of trading on the securities exchange	Number
OneYearTargetEst	The projected price level as stated by an investment analyst or advisor.	Number
AvgVolume	The number of shares traded per day, averaged over some time period, usually one year.	Number
MarketCap	Market value of a company	Number

 Database Tables also have same fields as shown in the Table 7.1.

NOTE

By default JMS Event is in the deactivated state. It must be activated before executing the Process Flow. When in activated state, JMS event continuously listens for data from JMS Server. JMS Event on receiving the data, is fired, and in turn triggers the Process Flow. After execution of the Process Flow, JMS Event again starts listening for new data.

PREREQUISITES

- OpenJMS must be installed and running.

 To know how to install and configure OpenJMS, refer to [Appendix A: Setting up OpenJMS.](#)

- Ensure that Queue is available in OpenJMS. *Queue1* is the default queue for OpenJMS.
- Table must be present in database server used as target.

 To know, how to create table into your database, refer to [Creating Table into Database](#) section.

- Before executing this process flow, you must edit the following activities to point to the database which is used as source:

EvalXform_DBDriver
EvalXform_DBInfo



To know, how to edit these activities refer to [Editing Activities](#) section.

CREATING TABLE INTO DATABASE

In this process flow, a database table is used as target. A SQL script is provided with Adeptia Suite to create a table in your database. This SQL script is located in `../AdeptiaServer-5.0/Serverkernel/Solutions/Demo/EvalJMSE` folder. To create table where data is to be populated into your target database, you need to execute the respective SQL Script, using the database client application.

USING ANOTHER JMS SERVER

The sample Process Flow is configured with OpenJMS server. If another JMS Server is to be used, some activities must be changed. These activities are outlined as:

- EvalJMSE_JMSProvider
- EvalJMSE_JMSEvent



To know, how to edit these activities refer to the [Editing Activities](#) section.

EXECUTING AND MONITORING

This section explains the execution and monitoring of sample Process Flow. Steps involved in execution of this sample Process Flow can be broadly divided as:

1. Activating JMS Event
2. Sending data to JMS Server
3. Monitoring Process Flow execution

Activating JMS Event

By default, JMS Event is in *deactivated* state. It must be activated before executing the sample Process Flow.

Steps to activate the JMS Event

1. In the Adeptia Suite homepage menu, click **[+] Deploy** to expand the tree. All the items in the **Deploy** category are displayed.

- Click **[+] Events & Triggers** to expand the tree and then click **JMS**. The Manage JMS Event screen is displayed with the list of existing JMS Events (see Figure 7.2).



Deploy > Events & Triggers > JMS							
New Edit Delete Revisions Dependencies							
--Select Field to Search--							Search
Activate							
#	Name	Description	PF	Owner	Perm.	Modified	
1	<input type="radio"/> EvalJMSE_JMSEvent	JMS Event to trigger Process Flow	View	demouser	RWX	10/04/05 13:23	

Figure 7.2: Manage JMS Event

- To activate the JMS Event (**EvalJMSE_JMSEvent**), select the radio button adjacent to *EvalJMSE_JMSEvent* and then click **Activate** link. A screen is displayed confirming that the JMS Event activity has been activated successfully.

Sending Data to JMS Server

Once the JMS Event is activated, it starts listening for the data from JMS Server. To execute the sample Process Flow, you only need to send the data to the JMS Server. After the data is sent to the JMS Server, the JMS Event triggers the Process Flow.

The sample data file, *EvalJMSE_StockQuotes.txt*, is located in `<drive>/<base directory>/Solutions/Demo/EvalJMSE` directory. The batch file, *EvalJMSE.bat*, is also saved in the same directory. This batch file is used to send the sample data file, *EvalJMSE_StockQuotes.txt*, to the JMS Server.

Steps to send data to the JMS Server

- Enter the command, `'Cd ../../Solutions/Demo/EvalJMSE'` at the command prompt.
- Execute the *EvalJMSE_JMS.bat* batch file. The JMS dialog box is displayed (see Figure 7.3).

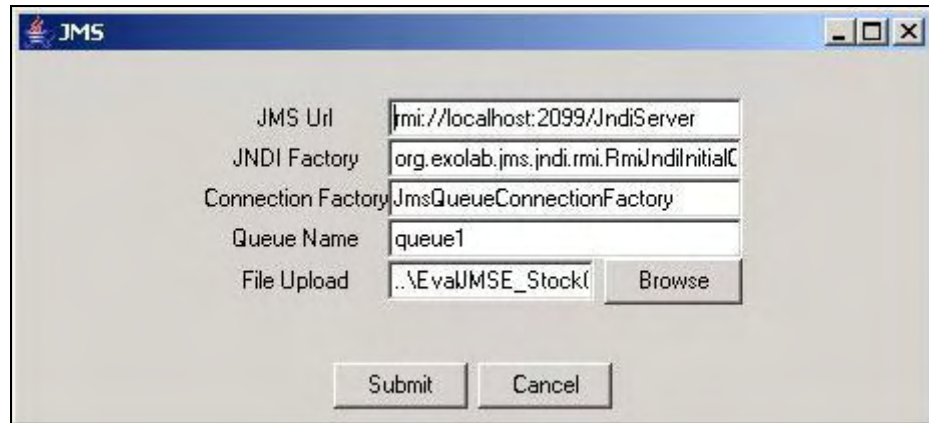



Figure 7.3: Send File to OpenJMS Server

3. Click **Submit** to send the data to the OpenJMS Server.



If you are using another JMS Server, change the required parameters and then click the **Submit** button.

Once the data is sent to the JMS Server, JMS Event triggers the Process Flow.

Monitoring Process Flow Execution

During execution of the Process Flow you can view status of the Process Flow as well as status of each activity of the Process Flow.

Steps to monitor Process Flow execution

1. In the Adeptia Suite homepage menu, click **[+] History** to expand the tree. All the items in the **History** category are displayed.
2. Click **Process Flow Log**. The Process Flow Log screen is displayed (see Figure 7.4).

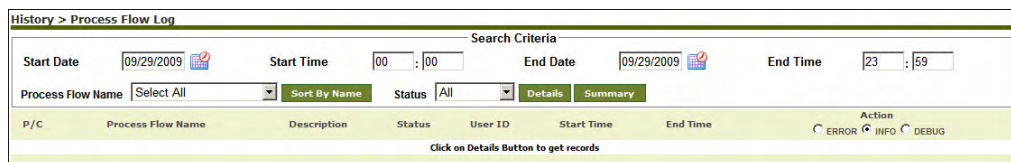

Figure 7.4: Process Flow Log

3. Select the Process Flow (*EvalJMSE_ProcessFlow*) from the *Select Process Flow Name* drop-down list and select *Executed* from the *Status* drop-down list.
4. Click the **Details** button. This displays the list of activities of the selected process flow conforming to the entered criteria (see Figure 7.5).

Reports > Process Flow Log

Search Criteria

Start Date: 10/04/2007 Start Time: 00:00 End Date: 10/04/2007 End Time: 23:59

Process Flow Name: EvalJMSE_ProcessFlow Sort By Name Status: Executed Details Summary

P/C	Process Flow Name	Description	Status	User ID	Start Time	End Time	Action
	EvalJMSE_ProcessFlow	Process Flow for JM...	Executed	admin	10/04/2007 17:49:47	10/04/2007 17:50:38	Details Repository Summary
	EvalJMSE_ProcessFlow	Process Flow for JM...	Executed	admin	10/04/2007 17:49:47	10/04/2007 17:50:38	Details Repository Summary
	EvalJMSE_ProcessFlow	Process Flow for JM...	Executed	admin	10/04/2007 17:49:49	10/04/2007 17:50:38	Details Repository Summary
	EvalJMSE_ProcessFlow	Process Flow for JM...	Executed	admin	10/04/2007 17:49:45	10/04/2007 17:50:38	Details Repository Summary
	EvalJMSE_ProcessFlow	Process Flow for JM...	Executed	admin	10/04/2007 17:49:48	10/04/2007 17:50:31	Details Repository Summary
	EvalJMSE_ProcessFlow	Process Flow for JM...	Executed	admin	10/04/2007 17:49:49	10/04/2007 17:50:27	Details Repository Summary
	EvalJMSE_ProcessFlow	Process Flow for JM...	Executed	admin	10/04/2007 17:49:49	10/04/2007 17:50:27	Details Repository Summary
	EvalJMSE_ProcessFlow	Process Flow for JM...	Executed	admin	10/04/2007 17:49:45	10/04/2007 17:50:27	Details Repository Summary
	EvalJMSE_ProcessFlow	Process Flow for JM...	Executed	admin	10/04/2007 17:49:45	10/04/2007 17:50:24	Details Repository Summary
	EvalJMSE_ProcessFlow	Process Flow for JM...	Executed	admin	10/04/2007 17:49:45	10/04/2007 17:50:24	Details Repository Summary
	EvalJMSE_ProcessFlow	Process Flow for JM...	Executed	admin	10/04/2007 17:49:38	10/04/2007 17:49:58	Details Repository Summary
	EvalJMSE_ProcessFlow	Process Flow for JM...	Executed	admin	10/04/2007 17:49:38	10/04/2007 17:49:49	Details Repository Summary

Figure 7.5: Searched Process Flows

- Click **Details** in the **Action** column of the activity of which you want to view execution details. This displays the Detailed Process Flow Activity Execution screen (see Figure 7.6).

Process Flow Log Details

Process Flow Name : EvalJMSE_ProcessFlow
Process Flow PID : 192168001007119150038742600431

Date/Time	Activity Name	Activity Type	Status	Message	Level	Location
10/04/2007 17:50:38	EvalJMSE_ProcessFlow	Transaction	Executed	Activity disposed. Start Time:2007-10-04 17:49:47 End Time:2007-10-04 17:50:38 Run Time:50 second(s) 763 ms	INFO	services.AbstractService(ABSTRACTSERVICE.JAV
10/04/2007 17:50:38	EvalJMSE_ProcessFlow	Transaction	Running	Context Information: {TransactionAddress=localhost:/indigo.Transaction[19216800119112186252720600004!192168001007119150038742600431];type=Transaction,name=EvalJMSE_ProcessFlow,id=19216800119112186252720600004,pid=192168001007119150038742600431, EventContextMap={EventID=JmsEvent:192168001001112419882071800001, EventName=EvalJMSE_JMSEvent, stream=NAME ADDRESS EMAIL_ID PHONE_NO DOB DEPT SALARY DOJ DESIGNATION AGE David" (34) Coffin <12-street> dcoffin01@snet.net 689567 04/04/1976production 5894 04-06-1996 executive 26 }, currentState=state-BPMN:TASK:BASIC_TASK-9, EvalJMSE_ContextSource=, LoggingLevel=INFO}	INFO	services.AbstractService(ABSTRACTSERVICE.JAV
10/04/2007 17:50:36	EvalJMSE_DbTarget	DatabaseTarget	Executed	Activity disposed. Start Time:2007-10-04 17:50:31 End Time:2007-10-04 17:50:36 Run Time:4 second(s) 627 ms	INFO	services.AbstractService(ABSTRACTSERVICE.JAV
10/04/2007 17:50:35	EvalJMSE_DbTarget	DatabaseTarget	Running	Execute	INFO	services.AbstractService(ABSTRACTSERVICE.JAV
10/04/2007 17:50:31	EvalJMSE_DbTarget	DatabaseTarget	Running	Initialize	INFO	services.AbstractService(ABSTRACTSERVICE.JAV
10/04/2007 17:50:29	EvalJMSE_Mapping	DataMapping	Executed	Activity disposed. Start Time:2007-10-04 17:50:19 End Time:2007-10-04 17:50:29 Run Time:10 second(s) 736 ms. Operation count:112 Bytes Average:10.432191 operations/sec	INFO	services.AbstractService(ABSTRACTSERVICE.JAV
10/04/2007 17:50:27	EvalJMSE_Mapping	DataMapping	Running	Execute	INFO	services.AbstractService(ABSTRACTSERVICE.JAV
10/04/2007 17:50:19	EvalJMSE_Mapping	DataMapping	Running	Initialize	INFO	services.AbstractService(ABSTRACTSERVICE.JAV
10/04/2007 17:50:10	EvalJMSE_TextSchema	Stream2XmlStreamTransformer	Executed	Activity disposed. Start Time:2007-10-04 17:50:01 End Time:2007-10-04 17:50:10 Run Time:9 second(s) 474 ms	INFO	services.AbstractService(ABSTRACTSERVICE.JAV

Close Window

Figure 7.6: Process Flow Log Details

- To view the summary of all instances of the process flow execution, click the **Summary** button. This displays the Process Flows Summary screen (see Figure 7.7).

Process Flows Summary between 10/04/2007 00:00:00 and 10/04/2007 23:59:59				
Start Time -> End Time ->	Process Flows	before 10/04/2007 00:00:00	after 10/04/2007 00:00:00	after 10/04/2007 00:00:00
		before 10/04/2007 23:59:59	before 10/04/2007 23:59:59	after 10/04/2007 23:59:59
Process Flows	Successful	0	17	0
	Aborted	0	0	0
	Executed	0	17	0

[Close Window](#)

Figure 7.7: Process Flows Summary

EDITING ACTIVITIES

Activities used in this sample Process Flow are pre-created. This section describes the process of editing these pre-created activities.

Editing JMS Provider (EvalJMSE_JMSProvider)

JMS Provider is used to connect to JMS Server. While creating JMS Provider, you need to specify the Provider Jar files, which are used to connect to JMS server. JMS Event further uses JMS Provider. This should be noted that JMS Provider does not directly take part in the creation of Process Flow. It just helps the JMS Event to connect to the JMS Server.

Steps to edit JMS Provider:

1. In Adeptia Suite homepage menu, click **[+] Configure** to expand the tree. All the items in the **Configure** category are displayed.
2. Click **[+] Services** to expand the tree and then click **[+] Connector**. All the items in the **Connector** category are displayed.
3. Click **JMS Provider**. The Manage JMS Provider screen is displayed with the list of existing JMS Providers (see Figure 7.8).

Administer > Connector > JMS Provider						
New Edit Delete Revisions Dependencies						
--Select Field to Search--						Search
#	Name	Description	Owner	Perm.	Modified	
1	<input type="radio"/> EvalJMSE_JMSProvider	JMS Provider for Open JMS	evalUser	RWX	08/22/05 14:15	
2	<input type="radio"/> EvalRec_JMSProvider	JMS Provider to connect open JMS	evalUser	RWX	08/12/05 17:23	

Figure 7.8: Manage JMS Provider

4. Select the radio button adjacent to *EvalJMSE_JMSProvider* activity and then click **Edit** link. This displays the Edit *EvalJMSE_JMSProvider* activity screen, with properties of the activity displayed in their respective fields (see Figure 7.9).

Configure > Services > Connector > JMS Provider > EvalJMSE_JMSProvider

[-] Standard properties

Name *	EvalJMSE_JMSProvider
Description *	JMS Provider for Open JMS
JMS URL *	rmi://localhost:2099/JndiServer
Provider Jar Files*	exolabcore-0.3.7.jar,jms-1.0.2a.jar,jn Upload Jars
JNDI Factory *	org.exolab.jms.jndi.rmi.RmiJndiInitial
Queue Connection Factory *	JmsQueueConnectionFactory
Topic Connection Factory *	JmsTopicConnectionFactory

[+] Advanced properties

* Mandatory fields.

Save
Save As
Cancel

Figure 7.9: Edit JMS Provider Activity

A detailed description of fields on this screen is explicated in the table below.

Table 7.2: Details of Fields on Edit JMS Provider Screen

Field Name	Field Description
Name	Name of the JMS Provider
Description	Description of the JMS Provider
JMS URL	URL of the JMS Server
Provider Jar Files	Jar files, which are used to connect to JMS servers. Click Upload Jars button to browse and upload Jar files.
JNDI Factory	The factory name used to access the external JMS JNDI name service.
Queue Connection Factory	Queue connection factory is used to create connections to the associated JMS provider of JMS queues, for point-to-point messaging.
Topic Connection Factory	JMS topic connection factory is used to create connections to the associated JMS provider of JMS topics, for publish/subscribe messaging.

5. Make the necessary changes.
6. Once you have made the required changes, click the **Save** button to save the changes. A screen is displayed confirming that the JMS Provider has been updated successfully. If the *comments* property is enabled, then clicking **Save** will display a screen where you need to enter comments related to updating the JMS Provider (see Figure 7.10).

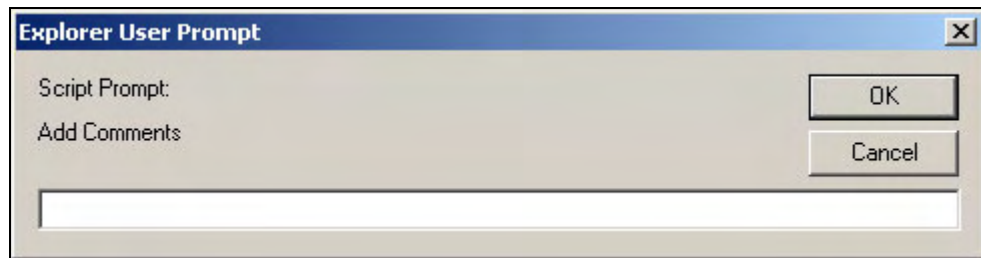
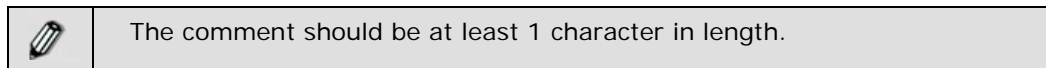
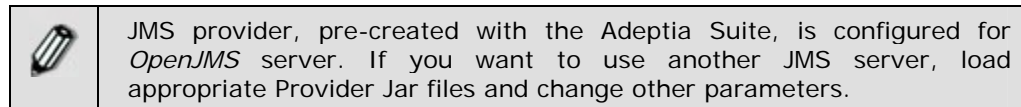

Figure 7.10: Enter Comments

7. Enter the comments in the *Add Comments* field.



8. Click **OK** to save the comments. This displays a screen confirming that the JMS Provider has been updated successfully.



Editing JMS Event (EvalJMSE_JMSEvent)

JMS Event activity is used to trigger the Process Flows, when a message is found on a JMS Server. In JMS Event activity, you can specify connection type and message selector criteria of the JMS Server.

Steps to edit the JMS Event activity

1. In the Adeptia Suite homepage menu, click **[+] Deploy** to expand the tree. All the items in the **Deploy** category are displayed.
2. Click **[+] Events & Triggers** to expand the tree and then click **JMS**. The Manage JMS Event screen is displayed with the list of existing JMS Event activities (Refer to Figure 7.2).
3. Select the radio button adjacent to *EvalJMSE_JMSEvent* and then click **Edit** link. This displays the Edit *EvalJMSE_JMSEvent* activity screen, with the properties of the activity displayed in their respective fields (see Figure 7.11).

Deploy > Events & Triggers > JMS > EvalJMSE_JMSEvent

[-] Standard properties

Name *

Description *

JMS Provider*

Connection Type*

Durable Subscriber

SubscriberID

Queue Or Topic Name *

MessageSelector

UserName

Password

Confirm Password

[+] Advanced properties

* Mandatory fields.

Figure 7.11: Edit JMS Event Activity

A detailed description of fields on this screen is explicated in the table below.

Table 7.3: Details of Fields on Edit JMS Events Screen

Field Name	Field Description
Name	Name of the JMS Event activity
Description	Description of the JMS Event activity
JMS Provider	JMS Provider used to connect to JMS Server. For more details, refer to the section Editing JMS Provider .
Connection Type	JMS Connection type, either TOPIC or QUEUE TOPIC Used for one to many messaging. It supports publish subscribe model of messaging. QUEUE Used for one-to-one messaging. It supports Point-to-Point Messaging.
Durable Subscriber	If a client needs to receive all the messages published on a topic, including the ones published while the subscriber is inactive, it uses a Durable Subscriber. This is applicable only when the connection type is Topic .
Subscriber ID	Uniquely identify the subscriber of the connection
Queue or Topic Name	Name of the Queue or Topic from which JMS Event receives data

Create Dynamically	Creates Queue or Topic specified above if it does not already exist in the specified JMS Server
Message Selector	Used to filter the messages received from JMS Server.
Username	Username required to connect to JMS Server
Password	Password required to connect to JMS Server
Confirm Password	Re-enter the Password

4. Make the necessary changes.
5. Once you have made the required changes, click the **Save** button to save the changes. A screen is displayed confirming that the JMS Event activity has been updated successfully. If the *comments* property is enabled, then clicking **Save** will display a screen where you need to enter comments related to updating the JMS Event (refer to Figure 7.10).
6. Enter the comments in the *Add Comments* field.

	The comment should be at least 1 character in length.
---	---

7. Click **OK** to save the comments. This displays a screen confirming that the JMS Event has been updated successfully.

	<ul style="list-style-type: none"> ▪ Pre-created JMS Event activity is configured to listen on queue1, which is default queue of the JMS Server. ▪ JMS Event activity must be deactivated before editing.
---	--

Editing Text Schema

(EvalJMSE_TextSchema)

Text Schema describes the structure of a text file. Text Schema activity is used to define, how a text file is read or written in a predefined format. To create a Text Schema activity, you need to specify the record separator, field separator and the field names of the text file.

Steps to edit the Text Schema

1. In the Adeptia Suite homepage menu, click **[+] Configure** to expand the tree. All the items in the **Configure** category are displayed.
2. Click **[+] Services** to expand the tree. All the items in the **Services** category are displayed.
3. Click **[+] Schema** to expand the tree, and then click **Text**. The Manage Text Schema screen is displayed with the list of existing Text Schema activities (see Figure 7.12).

Configure > Services > Schema > Text

New | Edit | Delete | Revisions | Dependencies --Select Field to Search-- Search

#	Name	Description	Owner	Perm.	Modified
1	<input type="radio"/> InventoryItemsCSVSchema	text schema for CSV file	demouser	RWX	08/08/09 09:06
2	<input type="radio"/> EvalScript_TextSchema	Text Schema for Employee data	demouser	RWX	08/22/05 22:03
3	<input type="radio"/> EvalJMSE_TextSchema	Text Schema for Stock Quotes	demouser	RWX	08/22/05 17:46

Figure 7.12: Manage Text Schema

- Select the radio button adjacent to *EvalJMSE_TextSchema* activity and then click **Edit** link. This displays the Edit *EvalJMSE_TextSchema* activity screen, with the properties of the activity displayed in their respective fields (see Figure 7.13).

Configure > Services > Schema > Text > EvalJMSE_TextSchema

[-] Standard properties

Name *

Description *

Data Header Present

Record Separator*

Field Separator*

Download Schema Definition File

Create Schema Definition*

Use Definition File

Enter the Fields Sequentially

#	FieldName	Type	DateFormat	TimeFormat
1	<input type="text" value="Symbol"/>	string	mmdyyy	hh:mm:ss
2	<input type="text" value="CompanyName"/>	string	mmdyyy	hh:mm:ss
3	<input type="text" value="LastTradePrice"/>	number	mmdyyy	hh:mm:ss
4	<input type="text" value="TradeTime"/>	date	mm/dd/yy	hh:mm:ss

Number of Rows at Position

[+] Advanced properties

* Mandatory fields.

Figure 7.13: Edit Text Schema Activity

A detailed description of fields on this screen is explicated in the table below.

Table 7.4: Details of Fields on Edit Text Schema Screen

Field Name	Field Description						
Name	Name of the Text Schema activity						
Description	Description of the Text Schema activity						
Data Header Present	Data Header usually contains the titles of the fields in a text file. If data header is present in the text file, check the Data Header Present checkbox						
Record Separator	Character or set of characters that are used to mark the end of a record. For Example <code>\n</code> for New Line .						
Field Separator	Character or set of characters that are used to separate fields. For example comma (,)						
Download Schema Definition File	Click Download to download the schema definition file.						
Create Schema Definition	Schema can be defined using one of the following options: <ul style="list-style-type: none"> ▪ Use Definition File ▪ Enter the Field Sequentially Pre-created schema with this sample Process Flow is created using second option i.e. Enter the Field Sequentially						
Field Name	Name of the Fields						
Data Type	There are three data types: <table border="0" style="width: 100%;"> <tr> <td style="width: 15%;">String</td> <td>String can be used for any type of data.</td> </tr> <tr> <td>Number</td> <td>Contains numbers</td> </tr> <tr> <td>Date</td> <td>Contains Date and Time</td> </tr> </table>	String	String can be used for any type of data.	Number	Contains numbers	Date	Contains Date and Time
String	String can be used for any type of data.						
Number	Contains numbers						
Date	Contains Date and Time						
Quotes Handling On	Suppose a character (say \$) is specified as Field Separator in a record. Now any \$ character in data field of that record (Chocolate\$20\$perpack) is considered as Field Separator, even though it is part of the data field. In the above example the \$ after 20 is also considered as Field Separator, whereas it is data. To avoid this situation put those fields within the double quotes i.e. (Chocolate\$"20\$perpack") and check Quotes Handling On checkbox. Now characters within double quotes are considered as one Field even though there is a \$ sign. <p>This option is available in <i>Advanced Properties</i> of Text Schema.</p>						

5. Make the necessary changes.
6. Once you have changed the required values, click the **Save** button to save the changes. A screen is displayed confirming that the Text Schema activity has been updated successfully. If the *comments* property is enabled, then clicking **Save** will display a screen where you need to enter comments related to updating the text schema (refer to Figure 7.10).
7. Enter the comments in the *Add Comments* field.

	The comment should be at least 1 character in length.
---	---

- Click **OK** to save the comments. This displays a screen confirming that the text schema has been updated successfully.

Testing Text Schema (EvalJMSE_TextSchema)

You can verify the text schema activity at design time.

Steps to verify schema activity

- Click **Test** button on the Edit Text Schema screen. The Test Schema screen is displayed (see Figure 7.14).

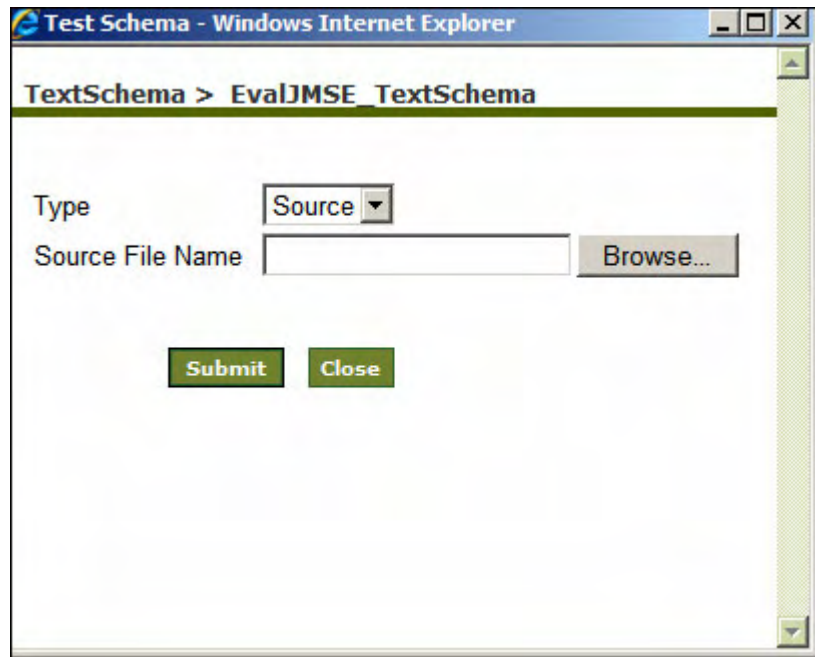

Figure 7.14: Test Schema

- Select the type of schema to test, from the *Type* drop-down list. By default, *Source* is selected.
- Enter the full path (with file name and extension) of the source file in the *Source File Name* field.
- Enter the full path of the XML target file, where it will be generated, in the *Target File Name* field.
- Enter the full path of the XML file where error records will be stored, in the *Error File Name* field.
- Click **Submit** button. This tests the validity of the text schema.

Editing Mapping (EvalJMSE_Mapping)

Mapping is used to map data fields of Source Schema with the data fields of Target Schema.

Steps to edit the Mapping activity

1. In the Adeptia Suite homepage menu, click **[+] Configure** to expand the tree. All the items in the **Configure** category are displayed.
2. Click **[+] Services** to expand the tree. All the items in the **Services** category are displayed.
3. Click **[+] Data Transform** to expand the tree, and then click **Data Mapping**. The Manage Data Mapping screen is displayed with the list of existing mapping activities (see Figure 7.15).

Configure > Services > Data Transform > Data Mapping						
New Edit Delete Revisions Dependencies						
--Select Field to Search--						Search
PDFView						
#	Name	Description	Owner	Perm.	Modified	
1	<input type="radio"/> EvalJMSE_Mapping	Text to Database Mapping	demouser	RWX	11/20/09 16:11	
2	<input type="radio"/> EvalScript_Mapping	Mapping between Text And Excel Schema	demouser	RWX	11/20/09 16:11	
3	<input type="radio"/> EvalXform_Mapping	Mapping between DB Schema and Excel.	demouser	RWX	11/20/09 16:11	
4	<input type="radio"/> EvalPF_MappingTransformation_Format1	Mapping transformation for format1	demouser	RWX	11/20/09 16:10	
5	<input type="radio"/> EvalPF_MappingTransformation_Format2	Mapping transformation for format2	demouser	RWX	11/20/09 16:10	
6	<input type="radio"/> InventoryItemsMapping_part2	convert CSV to XML. Includes data validation conditions.	demouser	RWX	08/09/09 10:29	
7	<input type="radio"/> InventoryItemsMapping_part1	convert CSV to XML	demouser	RWX	08/08/09 10:48	
8	<input type="radio"/> Fulfillment_ExcelToRequestXML	This mapping is used to convert excel data file to XML request message.	demouser	RWX	08/07/09 16:45	
9	<input type="radio"/> Fulfillment_ResponseXMLtoExcel	This mapping is used to convert web service response to excel.	demouser	RWX	08/07/09 13:20	
10	<input type="radio"/> Fulfillment_WSMMapping	This mapping is used in published Web Service process flow. Generates Shipping and Invoice information.	demouser	RWX	08/07/09 13:05	
11	<input type="radio"/> PurchaseOrderDataMapping	apply rules on XML and convert to Db format	demouser	RWX	08/06/09 15:54	
12	<input type="radio"/> EmployeeBenefitDataMapping	apply conversion rules	demouser	RWX	08/05/09 14:47	

Figure 7.15: Manage Data Mapping

4. Select the radio button adjacent to *EvalJMSE_Mapping* activity and then click **Edit** link. This displays the Edit *EvalJMSE_Mapping* activity screen, with the name and description of the activity displayed in their respective fields (see Figure 7.16).

Configure > Services > Data Transform > Data Mapping > EvalJMSE_Mapping

[-] Standard properties

Name *

Description *

Data Mapper

[+] Advanced properties

* Mandatory fields.

Save **Save As** **Cancel**

Figure 7.16: Edit *EvalJMSE_Mapping* Activity

- Click **Data Mapper** button. The Data Mapper applet is displayed showing the mapping between the data fields of the source and target schema (see Figure 7.17).

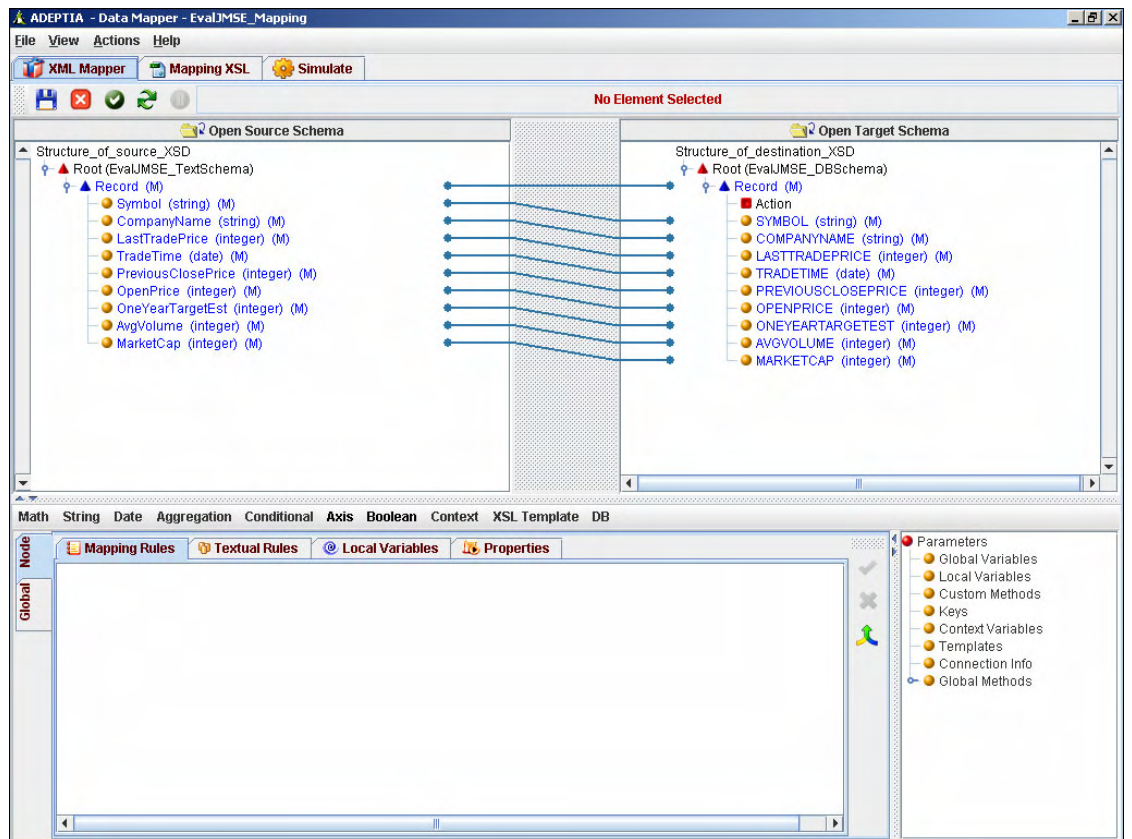



Figure 7.17: Mapping between Source and Target Schemas

6. Make the necessary changes to the mapping between the source and target schemas.
7. Once you have made the required changes, save the mapping by clicking **File** menu and selecting **Save**. A dialog box is displayed confirming that the mapping activity has been saved successfully.

	<p>Alternately, you can save the mapping by clicking Save () button on the Tool Bar.</p>
---	--

8. If the *comments* property is enabled, then clicking **Save** will display a screen where you need to enter comments related to the mapping. (see Figure 7.18).

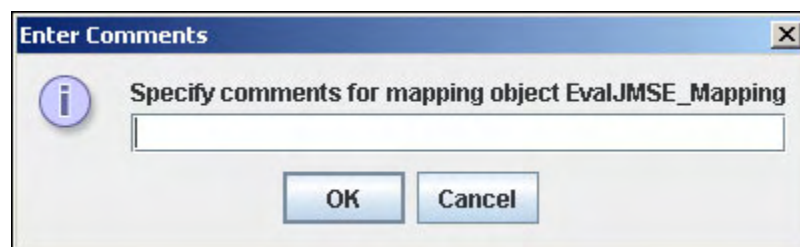



Figure 7.18: Enter Comments (Mapping)

9. Enter the comments in the *Specify comments for mapping object (object name)* field.

	<p>The comment should be at least 1 character in length.</p>
---	--

10. Click **OK** to save the comments. This displays a dialog box confirming that the mapping has been saved successfully.
11. Exit the Data Mapper applet by clicking **File** menu and selecting **Exit**.

Editing Database Driver (EvalJMSE_DBDriver)

Database Driver is used to specify the type of database and to upload driver jar files required to connect to that database.

Steps to edit Database Driver

1. In the Adeptia Suite homepage menu, click **[+] Configure** to expand the tree. All the items in the **Configure** category are displayed.
2. Click **[+] Services** to expand the tree and then click **[+] Connector**. All the items in the **Connector** category are displayed.
3. Click **Database Driver**. The Manage Database Driver screen is displayed with the list of existing Database Drivers (see Figure 7.19)

Configure > Services > Connector > Database Driver

New | Edit | Delete | Revisions | Dependencies

--Select Field to Search--

#	Name	Description	Owner	Perm.	Modified
1	<input type="radio"/> Oracle_DBDriver	Oracle server driver	demouser	RWX	11/24/09 15:36
2	<input type="radio"/> MySQLServer_DBDriver	MySQL server driver	demouser	RWX	01/25/08 12:50
3	<input type="radio"/> SQLServer_DBDriver	SQL server driver	demouser	RWX	01/25/08 12:49
4	<input type="radio"/> HSQL_DBDriver	Database driver for HSQL	demouser	RWX	01/22/08 21:11

Figure 7.19: Manage Database Driver

- Select the radio button adjacent to the Database Driver activity that is being used in *EvalJMSE_DbInfo* activity and then click **Edit link**. This displays the Edit *DBDriver* activity screen, with the properties of the activity displayed in their respective fields (see Figure 7.20).

Configure > Services > Connector > Database Driver > SQLServer_DBDriver

Standard properties

Name *

Description *

Upload Driver Jar/Zip files

Driver Main Class Name *

Advanced properties

* Mandatory fields.

Figure 7.20: Edit *SQLServerJTDSDriver*

A detailed description of fields on this screen is explicated in the table below.

Table 7.5: Details of Fields on Edit Database Driver Screen

Field Name	Field Description
Name	Name of the Database Driver
Description	Description of the Database Driver
Upload Driver Jar Files	JDBC Driver files, which are used to connect Database Server. Click the Browse Jars button to select Jar files. Following is the list of databases and the required Jar files:

	Oracle	ojdbc5.jar
	IBM DB2 (Ver 7.1)	db2java.zip (7.1 version)
	IBM DB2 (Ver 8.1)	db2jcc.jar
	MS SQL	msbase.jar, mssqlserver.jar and msutil.jar
	JTDS- SQL Server	Jtds.jar
	HSQL DB	hsqldb-1.7.2.jar
Driver Main Class Name	Driver Main Class Name is a fully qualified java class name for the main database driver class. The driver class name typically starts with a com. , net. or org. followed by the company domain, for example the JDBC driver class from mysql.com is called com.mysql.jdbc.Driver . Click the Help button to select Driver Main Class Name from the drop-down list. Following is the list of Driver Main Class Name of different databases:	
	Oracle	oracle.jdbc.driver.OracleDriver
	IBM DB2 (Ver 7.1)	COM.ibm.db2.jdbc.net.DB2Driver
	IBM DB2 (Ver 8.1)	com.ibm.db2.jcc.DB2Driver
	MS SQL	com.microsoft.jdbc.sqlserver.SQLServerDriver
	JTDS-SQL Server	net.sourceforge.jtds.jdbc.Driver
	HSQLDB	org.hsqldb.jdbcDriver
	MS Access	sun.jdbc.odbc.JdbcOdbcDriver
	MS Excel	sun.jdbc.odbc.JdbcOdbcDriver

5. Make the necessary changes.
6. Once you have changed the required values, click the **Save** button to save the changes. A screen is displayed confirming that the Database Driver has been updated successfully. If the *comments* property is enabled, then clicking **Save** will display a screen where you need to enter comments related to updating the Database Driver (refer to Figure 7.10).
7. Enter the comments in the *Add Comments* field.



The comment should be at least 1 character in length.

8. Click **OK** to save the comments. This displays a screen confirming that the Database Driver has been updated successfully.

Editing Database Info (EvalJMSE_DBInfo)

Database Info activity is used to specify the JDBC URL or Server URL and Username and Password to access the database. Database Info uses Database driver to connect to specified Database Server.

Steps to edit the Database Info

1. In the Adeptia Suite homepage menu, click **[+] Configure** to expand the tree. All the items in the **Configure** category are displayed.
2. Click **[+] Services** to expand the tree and then click **[+] Connector**. All the items in the **Connector** category are displayed.
3. Click **Database Info**. The Manage Database Info screen is displayed with a list of existing **Database Info** (see Figure 7.21).

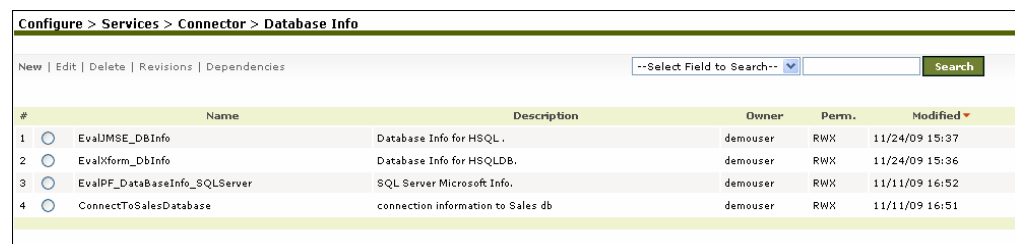

#	Name	Description	Owner	Perm.	Modified
1	<input type="radio"/> EvalJMSE_DBInfo	Database Info for HSQL .	demouser	RWX	11/24/09 15:37
2	<input type="radio"/> EvalXform_DbInfo	Database Info for HSQLDB.	demouser	RWX	11/24/09 15:36
3	<input type="radio"/> EvalPF_DataBaseInfo_SQLServer	SQL Server Microsoft Info.	demouser	RWX	11/11/09 16:52
4	<input type="radio"/> ConnectToSalesDatabase	connection information to Sales db	demouser	RWX	11/11/09 16:51

Figure 7.21: Manage Database Info

4. Select the radio button adjacent to *EvalJMSE_DBInfo* activity and then click **Edit** link. This displays the Edit *EvalJMSE_DBInfo* activity screen, with the properties of the activity displayed in their respective fields (see Figure 7.22).

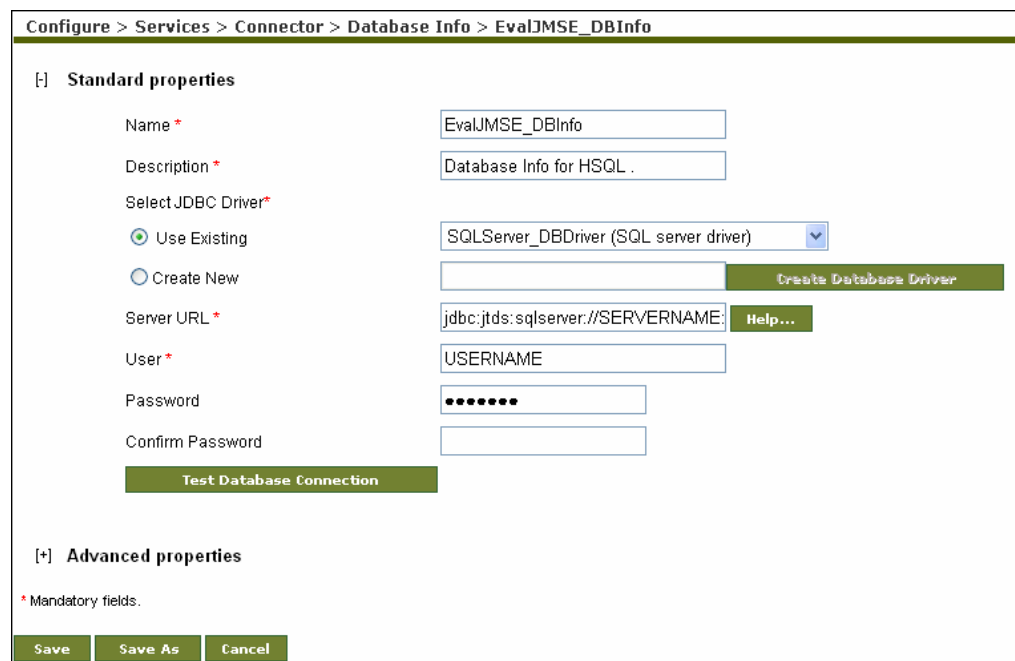

[-] Standard properties

Name *

Description *

Select JDBC Driver*

Use Existing

Create New

Server URL *

User *

Password

Confirm Password

[+] Advanced properties

* Mandatory fields.

Figure 7.22: Edit *EvalJMSE_DBInfo*

A detailed description of fields on this screen is explicated in the table below.

Table 7.6: Details of Fields on Edit Database Info Screen

Field Name	Field Description																								
Name	Name of the Database Info																								
Description	Description of the Database Info																								
JDBC Driver	Database Driver is created to connect to the database Server. For more details refer to section Editing Database Driver .																								
Server URL	<p>Server URL or JDBC URL points to a specific database on a specified database server. There is no standard for JDBC URL. Every JDBC driver uses a slightly different syntax. For Example a JDBC URL for a MySQL database using the <code>com.mysql.jdbc.Driver</code> direct from MySQL might look like this:</p> <p><code>jdbc:mysql://localhost/databaseName</code>. To specify Server URL, Click the Help button and enter the following information:</p> <table border="0"> <tr> <td>Database Type</td> <td>Type of the database</td> </tr> <tr> <td>Host Name</td> <td>Name of the server on which database server is running</td> </tr> <tr> <td>Port</td> <td>Port at which database server is running</td> </tr> <tr> <td>Database Name</td> <td>Name of the database</td> </tr> </table> <p>Following is the list of Server URL's of different databases:</p> <table border="0"> <tr> <td>Oracle</td> <td><code>jdbc:oracle:thin:@databaseserver:1521:orcl</code></td> </tr> <tr> <td>IBM DB2 (Ver 7.1)</td> <td><code>jdbc:db2://databaseserver:6789/TOOLSDB</code></td> </tr> <tr> <td>IBM DB2 (Ver 8.1)</td> <td><code>jdbc:db2://databaseserver:50000/TOOLSDB</code></td> </tr> <tr> <td>MS SQL</td> <td><code>jdbc:microsoft:sqlserver://databaseserver:1433;DatabaseName=master</code></td> </tr> <tr> <td>SQL JTDS</td> <td><code>jdbc:jtds:sqlserver://databaseserver:1433/master</code></td> </tr> <tr> <td>MS Access</td> <td><code>jdbc:odbc:Driver={Microsoft Access Driver (*.mdb)}; DBQ=c:/test/db1.mdb</code></td> </tr> <tr> <td>MS Excel</td> <td><code>Jdbc:odbc:ExcelJDBCTest</code> where <i>ExcelJDBCTest</i> is the ODBC object that you need to create using DSN.</td> </tr> <tr> <td>HSQL DB</td> <td><code>jdbc:hsqldb:hsq://databaseserver:2476</code></td> </tr> </table> <p>Here database server is the name of the server where database is running.</p>	Database Type	Type of the database	Host Name	Name of the server on which database server is running	Port	Port at which database server is running	Database Name	Name of the database	Oracle	<code>jdbc:oracle:thin:@databaseserver:1521:orcl</code>	IBM DB2 (Ver 7.1)	<code>jdbc:db2://databaseserver:6789/TOOLSDB</code>	IBM DB2 (Ver 8.1)	<code>jdbc:db2://databaseserver:50000/TOOLSDB</code>	MS SQL	<code>jdbc:microsoft:sqlserver://databaseserver:1433;DatabaseName=master</code>	SQL JTDS	<code>jdbc:jtds:sqlserver://databaseserver:1433/master</code>	MS Access	<code>jdbc:odbc:Driver={Microsoft Access Driver (*.mdb)}; DBQ=c:/test/db1.mdb</code>	MS Excel	<code>Jdbc:odbc:ExcelJDBCTest</code> where <i>ExcelJDBCTest</i> is the ODBC object that you need to create using DSN.	HSQL DB	<code>jdbc:hsqldb:hsq://databaseserver:2476</code>
Database Type	Type of the database																								
Host Name	Name of the server on which database server is running																								
Port	Port at which database server is running																								
Database Name	Name of the database																								
Oracle	<code>jdbc:oracle:thin:@databaseserver:1521:orcl</code>																								
IBM DB2 (Ver 7.1)	<code>jdbc:db2://databaseserver:6789/TOOLSDB</code>																								
IBM DB2 (Ver 8.1)	<code>jdbc:db2://databaseserver:50000/TOOLSDB</code>																								
MS SQL	<code>jdbc:microsoft:sqlserver://databaseserver:1433;DatabaseName=master</code>																								
SQL JTDS	<code>jdbc:jtds:sqlserver://databaseserver:1433/master</code>																								
MS Access	<code>jdbc:odbc:Driver={Microsoft Access Driver (*.mdb)}; DBQ=c:/test/db1.mdb</code>																								
MS Excel	<code>Jdbc:odbc:ExcelJDBCTest</code> where <i>ExcelJDBCTest</i> is the ODBC object that you need to create using DSN.																								
HSQL DB	<code>jdbc:hsqldb:hsq://databaseserver:2476</code>																								

5. Make the necessary changes.
6. Once you have made the required changes, click the **Save** button to save the changes. A screen is displayed confirming that the Database Info has been updated successfully. If the *comments* property is enabled, then clicking **Save** will display a screen where you need to enter comments related to updating the Database Info (refer to Figure 7.10).

7. Enter the comments in the *Add Comments* field.

	The comment should be at least 1 character in length.
---	---

8. Click **OK** to save the comments. This displays a screen confirming that the Database Info has been updated successfully.

	<p>In this sample Process Flow <i>HSQldb</i> is used as the source database. The data is actually available in <i>demo.script</i>, which is located in AdeptiaServer/AdeptiaServer4.8/ServerKernel/hsqldb/hsq1/demo.script.</p> <p>If you want to use another database, select the appropriate Server URL for that database.</p>
---	---

Editing Database Schema (EvalJMSE_DBSchema)

Database Schema defines the structure of a database table. A Database Schema is used to define how records can be read from a database table or can be written into a database table. In this sample process flow, Database Schema is being used at the target end. At the target end, it converts the data from an intermediate XML format into the database specific format. Database Schema uses Database Info activity to connect to the database Server. An important point to note is that the Database Schema does not directly take part in the creation of Process Flow. Since it is selected during the creation of the Database Target activity only this Database Target activity needs to be used in the Process Flow.

Steps to modify the Database Schema activity

1. In the Adeptia Suite homepage menu, click **[+] Configure** to expand the tree. All the items in the **Configure** category are displayed.
2. Click **[+] Services** to expand the tree. All the items in the **Services** category are displayed.
3. Click **[+] Schema** to expand the tree, and then click **Database**. The Manage Database Schema screen is displayed with a list of existing Database Schemas (see Figure 7.23).

Configure > Services > Schema > Database						
New Edit Delete Revisions Dependencies						
--Select Field to Search--						Search
Refresh						
#	Name	Description	Owner	Perm.	Modified	
1	EvalJMSE_DBSchema	Database schema for Stock Quotes	demouser	RWX	04/20/06 17:21	
2	EvalXform_DbSchema	Database Schema to parse Insurance data.	demouser	RWX	11/10/05 11:51	
3	EvalPF_DatabaseSchema_Database2	Database schema for database2	demouser	RWX	08/23/05 12:08	
4	EvalPF_DatabaseSchema_Database1	Database schema for database1	demouser	RWX	08/23/05 12:04	

Figure 7.23: Manage Database Schema

- Select the radio button adjacent to *EvalJMSE_DBSchema* activity and then click **Edit** link. This displays the Edit *EvalJMSE_DBSchema* activity screen, with the properties of the activity displayed in their respective fields (see Figure 7.24).

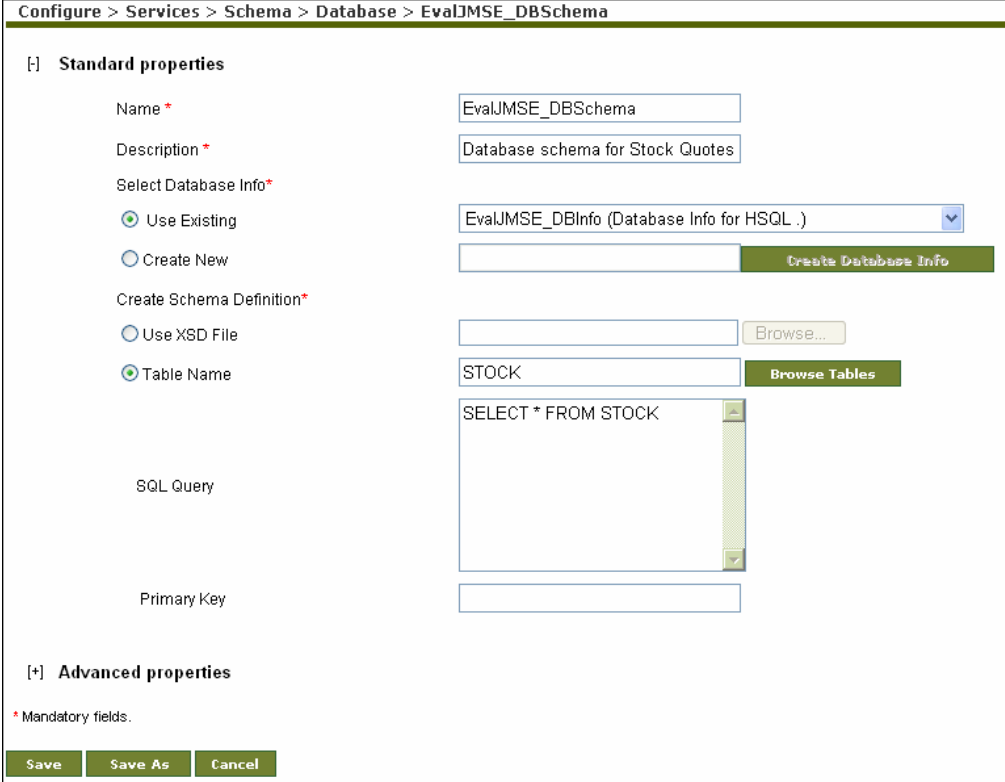

Configure > Services > Schema > Database > EvalJMSE_DBSchema

[+] Standard properties

Name *

Description *

Select Database Info*

Use Existing

Create New

Create Schema Definition*

Use XSD File

Table Name

SQL Query

Primary Key

[+] Advanced properties

* Mandatory fields.

Figure 7.24: Edit *EvalJMSE_DBSchema* Activity

A detailed description of fields on this screen is explicated in the table below.

Table 7.7: Details of Fields on Edit Database Schema Screen

Field Name	Field Description
Name	Name of the Database Schema
Description	Description of the Database Schema
JDBC Driver	Database Info is created to connect to the specified Database Server. For more details refer to section Editing Database Info .

Create Schema Definition	<p>Schema Definition can be created using one of the following options:</p> <ul style="list-style-type: none"> ▪ Use XSD File ▪ Table Name <p>Database Schema used in this Process Flow is created using second option i.e. Table Name. To select database tables, select Table Name radio button and then Click the Browse Tables. Select Table screen is displayed with the list of database Table. Select the required table and click Get Columns button. Click Close button to close the Select Table screen and return to Database Schema screen.</p> <p>SQL Query box automatically gets populated after selecting database tables.</p>
--------------------------	---

5. Make the necessary changes.
6. Once you have made the required changes, click the **Save** button to save the changes. A screen is displayed confirming that the Database Schema has been updated successfully. If the *comments* property is enabled, then clicking **Save** will display a screen where you need to enter comments related to updating the database schema (refer to Figure 7.10).
7. Enter the comments in the *Add Comments* field.

	The comment should be at least 1 character in length.
---	---

8. Click **OK** to save the comments. This displays a screen confirming that the database schema has been updated successfully.

Editing Database Target (EvalJMSE_DBTarget)

Database Target is used to insert the data into a database server. Database Target uses Database Info and Database Schema to get list of tables and their fields.

Steps to update the Database Target

1. In Adeptia Suite homepage menu, click **[+] Configure** to expand the tree. All the items in the **Configure** category are displayed.
2. Click **[+] Services** to expand the tree. All the items in the **Services** category are displayed.
3. Click **[+] Target** to expand the tree, and then click **Database**. The Manage Database Target screen is displayed with the list of existing Database Target activities (see Figure 7.25).

Configure > Services > Target > Database

New | Edit | Delete | Revisions | Dependencies

--Select Field to Search--

#	Name	Description	Owner	Perm.	Modified
1	<input type="radio"/> EvalPF_DatabaseTarget_Database2	database target database2	demouser	RWX	05/11/06 11:54
2	<input type="radio"/> EvalPF_DatabaseTarget_Database1	database target database1	demouser	RWX	08/22/05 18:57
3	<input type="radio"/> EvalJMSE_DBTarget	Database Target for Stock Quotes	demouser	RWX	08/22/05 18:33

Figure 7.25: Manage Database Target

- Select the radio button adjacent to *EvalJMSE_DBTarget* activity and then click **Edit** link. This displays the Edit *EvalJMSE_DBTarget* activity screen, with the properties of the activity displayed in their respective fields (see Figure 7.26).

Configure > Services > Target > Database > EvalJMSE_DBTarget

[-] Standard properties

Name *

Description *

Database Info *

Schema Name *

Database Operation * Insert Update Insert/Update Update/Insert

[+] Advanced properties

*Mandatory fields.

Figure 7.26: Edit *EvalJMSE_DBTarget* Activity

A detailed description of fields on this screen is explicated in the table below.

Table 7.8: Details of Fields on Edit Database Target Screen

Field Name	Field Description
Name	Name of the Database Target
Description	Description of the Database Target
Database Info	Database Info is created to connect to the specified Database Server. For more details refer to section Editing Database Info .
Schema Name	Database Schema, which describes the structure of database table. For more details refer to section Editing Database Schema .

Database Operation	<p>Database operation specifies how data records are inserted into database tables. Select one of the following database operations:</p> <ul style="list-style-type: none"> ▪ Insert ▪ Update ▪ Insert/Update ▪ Update/Insert <p>When Insert option is selected, records are inserted into the database tables. If records already exist in the database table, new records are added in the database table along with existing records. When a column (e.g. CompanyName) of database table is marked as Primary Key, more than one record cannot exist in the database table for the same Company Name. In this case if data of a company (i.e. XYZ) already exist, insert operation fails and data is not inserted into the database.</p> <p>Update option is selected when you want to update the existing record. To use updated option a column of database must be marked as Primary Key. When Update option is selected, database target first checks which column of the database table is marked as Primary Key. Suppose CompanyName column is marked as Primary Key. Now database target checks whether data of a company (e.g. XYZ) already exist or not. If data for XYZ already exists, database target updates the existing records. If none of the column is marked as Primary key, Update operation fails.</p> <p>When Insert/Update option is selected, database target first tries to insert the data into database table. If insert operation fails, database target tries to update the data.</p> <p>When Update/Insert option is selected, database target first tries to update the database table. If update operation fails, database target tries to insert the data.</p> <p>Note: To know, how to mark a column of a database table as Primary Key, refer to the documentation of Database Server you are using.</p> <p>In this sample Process Flow Insert option is used. Every time this Process Flow executes, it adds data along with the existing data.</p>
--------------------	---

5. Make the necessary changes.
6. Once you have made the required changes, click the **Save** button to save the changes. A screen is displayed confirming that the Database Target activity has been updated successfully. If the *comments* property is enabled, then clicking **Save** will display a screen where you need to enter comments related to updating the database target (refer to Figure 7.10).
7. Enter the comments in the *Add Comments* field.

	The comment should be at least 1 character in length.
---	---

8. Click **OK** to save the comments. This displays a screen confirming that the database target has been updated successfully.

CREATING PROCESS FLOW

(EvalJMSE_ProcessFlow)

A Process Flow is the set of activities arranged in a sequence to perform specific task(s). It is created by combining various activities i.e. Source, Target, Schema or Transformer etc. Process Designer is used to create a Process Flow. Process Designer has a list of activities created. You only need to arrange them in a logical sequence and connect them with the BPMN Flows.

Steps to create JMS Driven Process Flow

1. In the Adeptia Suite homepage menu, click **[+] Design** to expand the tree. All the items in the **Design** category are displayed.
2. Click **[+] Process Flow** to expand the tree and then click **Process Flow**. The Manage Process Flow screen is displayed with the list of existing Process Flows (see Figure 7.27).

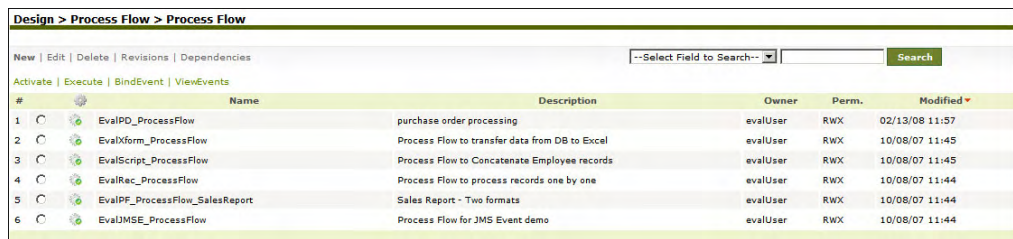

#	Name	Description	Owner	Perm.	Modified
1	EvalPD_ProcessFlow	purchase order processing	evalUser	RWX	02/13/08 11:57
2	EvalXform_ProcessFlow	Process Flow to transfer data from DB to Excel	evalUser	RWX	10/08/07 11:45
3	EvalScript_ProcessFlow	Process Flow to Concatenate Employee records	evalUser	RWX	10/08/07 11:45
4	EvalRec_ProcessFlow	Process Flow to process records one by one	evalUser	RWX	10/08/07 11:44
5	EvalPF_ProcessFlow_SalesReport	Sales Report - Two formats	evalUser	RWX	10/08/07 11:44
6	EvalJMSE_ProcessFlow	Process Flow for JMS Event demo	evalUser	RWX	10/08/07 11:44

Figure 7.27: Manage Process Flow

3. Click the **New** link. The Create Process Flow screen is displayed (see Figure 7.28).

Design > Process Flow

[-] Standard properties

Name*

Description*

Logging Level* ERROR ▾

Repository File Retention* DONT DELETE ▾

Process Flow Designer

[+] Advanced properties

*Mandatory fields.

Save Cancel

Figure 7.28: Create Process Flow

4. Enter the name and the description of the new Process Flow in the *Name* and *Description* fields respectively.
5. Select the logging level from the *Logging Level* drop-down list.

There are four levels of logging. These are described in the table below.

Table 7.9: Logging Levels

Level	Description
DEBUG	The DEBUG level logs fine-grained informational events that are most useful to debug any problem. Debug level is useful for programmers
INFO	The INFO level logs informational messages that highlight the progress of Process Flow execution. In INFO, status (successful or failure) of each activity is shown.
ERROR	In ERROR, possible cause of failure of an activity is shown.
DEFAULT	If you select Default, logging level, which is set as default in System Configuration, is selected.

6. Select repository file retention from the *Repository File Retention* option. During execution, the Process Flow creates a temporary repository file to store intermediate data. These repository files can cause unnecessary disk space usage and you may want to delete them after execution of the Process Flow. On the other hand, sometime these repository files can be helpful in case of the failure of the Process Flow execution. For each instance of the Process Flow execution a unique repository folder is created that contains Source, intermediate XML data files, and target formatted data. By default repository files are being stored in the repository folder of the Adeptia Suite. You can also choose an option to delete them or to archive them in a different location.

There are four options for the Repository File Retention. These are described in the table below.

Table 7.10: Repository File Retention Options

Retention Option	Description
DONTDELETE	Repository files are not deleted after execution of Process Flow.
DELETE	Repository files are deleted after the Process Flow is executed.
ARCHIVE	Repository files are moved to another location. By default repository files are archived in C:\repo folder.
DELETE ON SUCCESS	Repository files are deleted only when the process flow is executed successfully and there is no error record.

- Click the **Process Designer** button to open Process Designer. The Process Designer screen is displayed (see Figure 7.29).

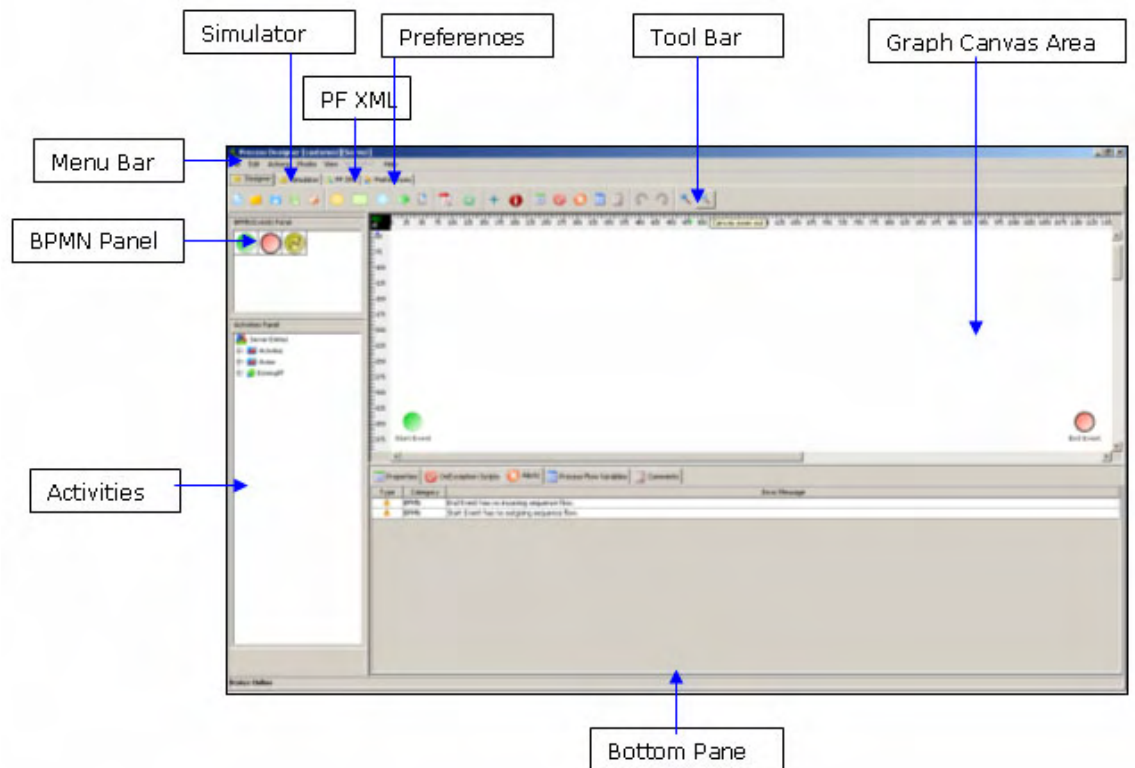





Figure 7.29: Process Designer Applet

 The **Activities Panel** has been renamed to **Repository View**. It is not reflected in this.

8. Once the Process Designer screen is displayed, a message to synchronize the list of activities and Process Flow with the Adeptia Suite is displayed. Click **OK** to synchronize.



Alternately, you can synchronize the list of activities and Process Flow with the Adeptia Suite by clicking the **Synchronize** () button displayed on the Tool Bar.

9. To create the Context Source, click **[+] Source** in Repository View, to expand the list of Source activities.
10. Click **[+] Context Source** activity to expand the Context Source activity. The Context Source node is displayed.
11. Drag the Context Source node to the Graph Canvas Area (see Figure 7.30).

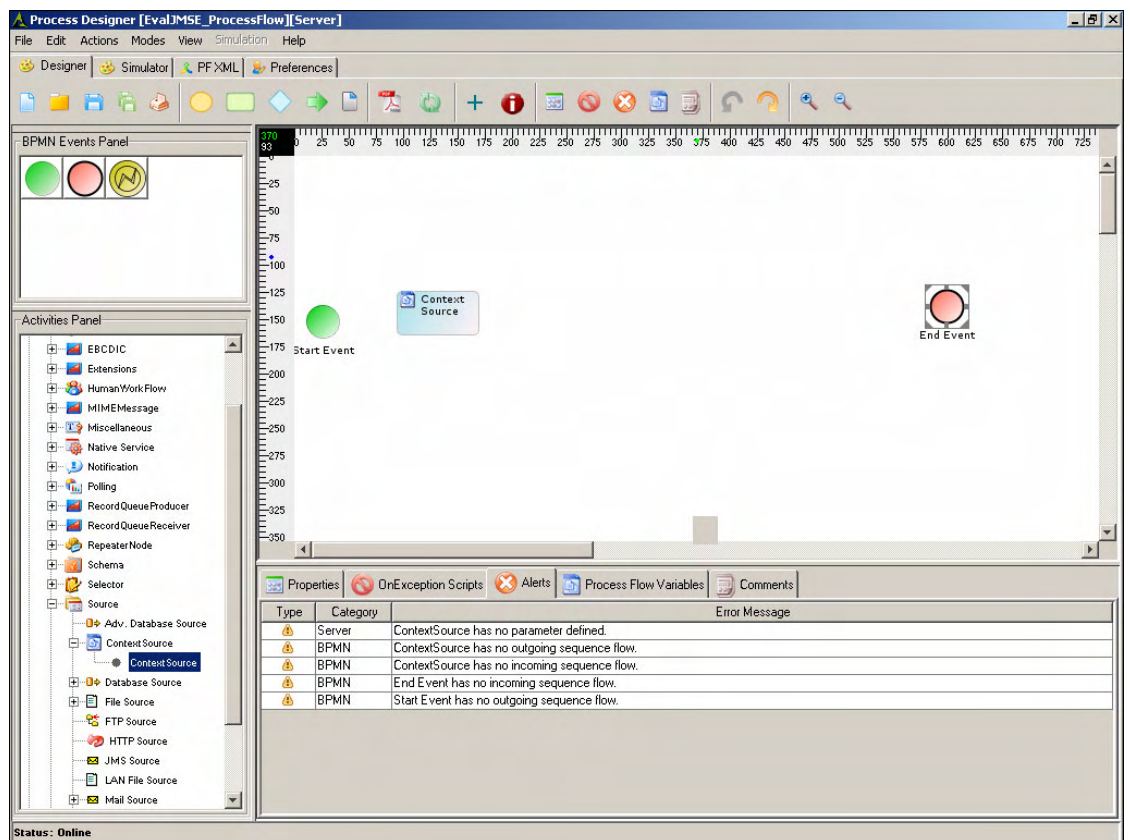

Figure 7.30: Drag Context Source to Graph Canvas

12. Right-click the **Context Source** node and select **View Properties**. Properties of the Context Source activity are displayed in the Bottom Pane (see Figure 7.31).

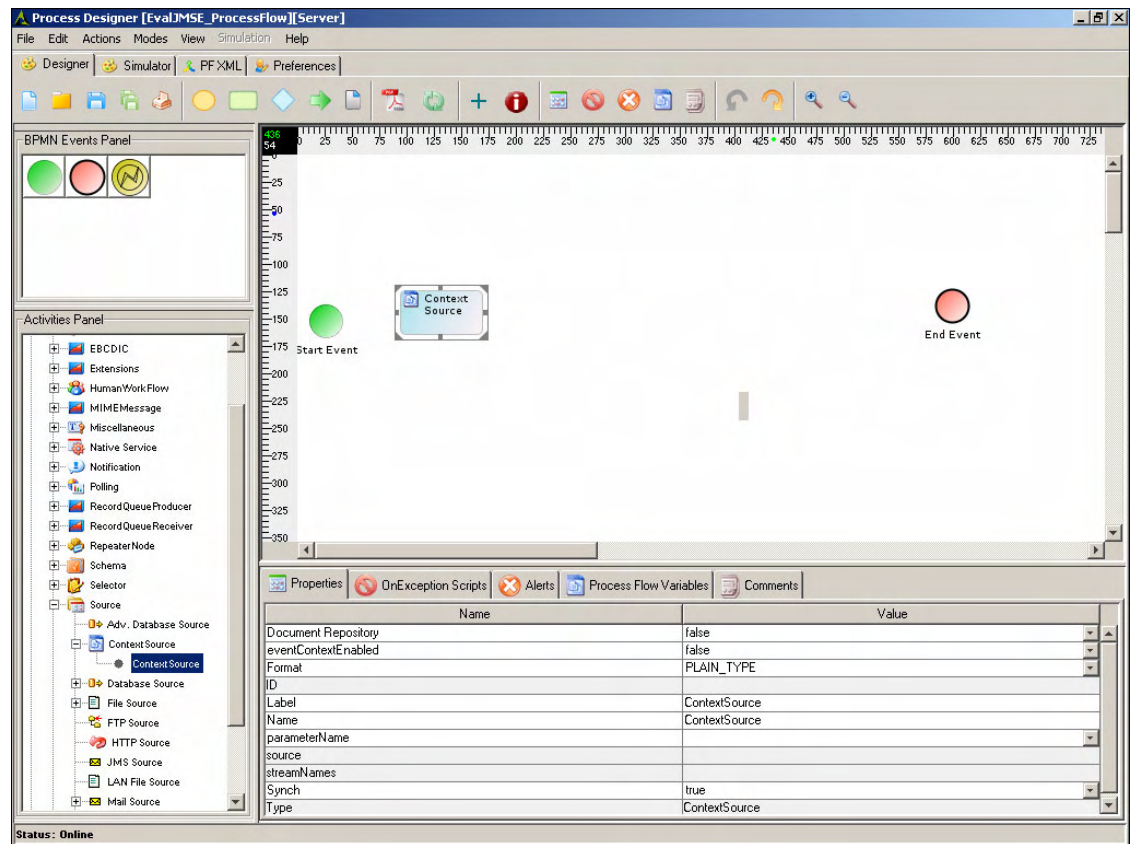

Figure 7.31: View Properties of Context Source Activity

13. Change the Name and Label of the context source as *EvalJMSE_ContextSource*.
14. Change the value of the property *eventContextEnabled* from *false* to *true* (see Figure 7.32).

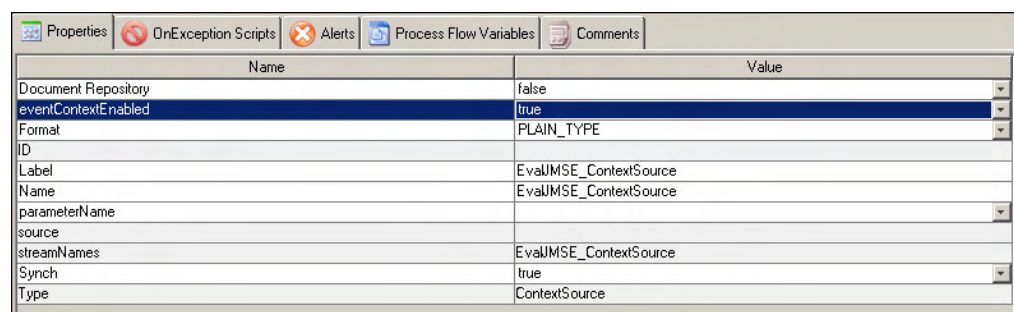

Figure 7.32: Context Source Name

15. Click **[+] Activities** in the Activities Panel to expand the list of services and then click **[+] Schema**. All the items in the **Schema** category are displayed.
16. Click **[+] Text Schema**. A list of existing Text Schema activities is displayed.
17. Select **EvalJMSE_TextSchema** and drag it to the Graph Canvas Area (see Figure 7.33).



Figure 7.33: Drag Text Schema to Graph Canvas Area

18. Click **[+] DataTransform** and then **[+] Data Mapping**. Select **EvalJMSE_Mapping** activity and drag it to the Graph Canvas Area.
19. Click **[+] Target** and then **[+] Database Target**. Select **EvalJMSE_DBTarget** activity and drag it to the Graph Canvas Area (see Figure 7.34).

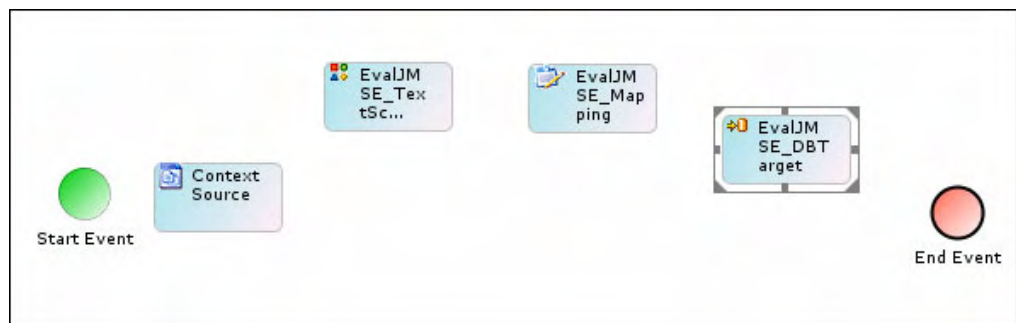

Figure 7.34: Drag Database Target to Graph Canvas Area

20. Once all the activities are dragged to the Graph Canvas Area, they must be connected using appropriate BPMN Flows or Control Flows.
21. Click the **Sequence Flow** (→) icon in the Palette. The Sequence flow is selected.
22. Drag the mouse pointer from *Start Event* to *Context Source* to connect *Start Event* with *EvalJMSE_ContextSource* (see Figure 7.35).

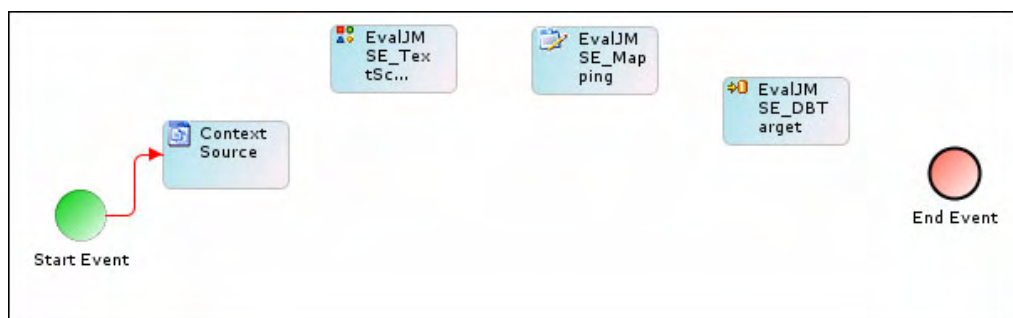

Figure 7.35: Connect Start Event to Context Source

23. Similarly, connect all other activities as shown in Figure 7.36.

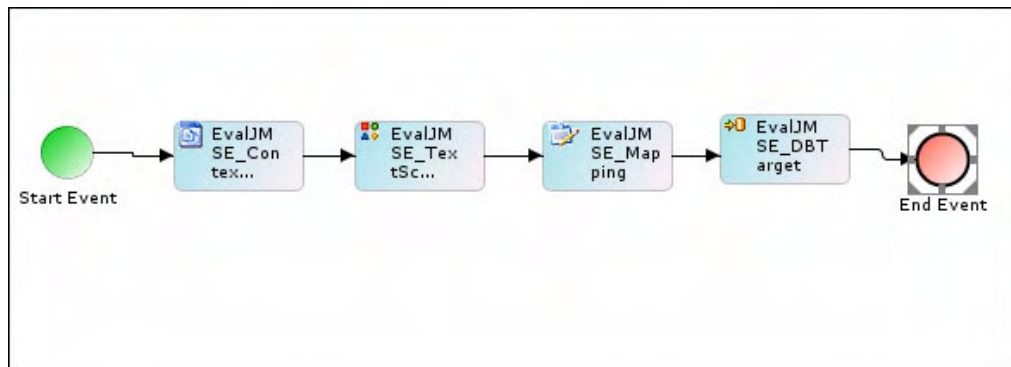

Figure 7.36: Connect all Activities

24. Save the Process Flow by clicking the **File** menu and selecting **Save to Server**. A dialog box is displayed confirming that the *EvalJMSE_ProcessFlow* has been saved successfully. If the *comments* property is enabled, then clicking **Save Process Flow to Server** will display a screen where you need to enter comments related to creating the process flow (see Figure 7.37).

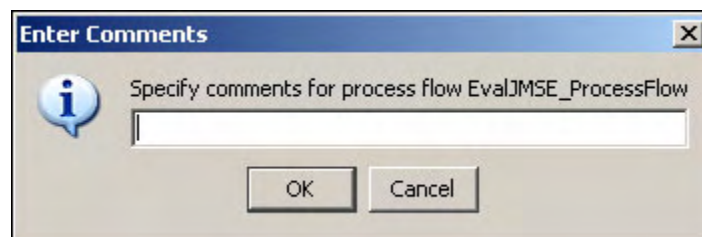
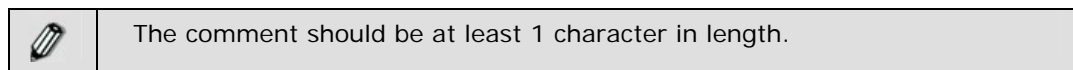

Figure 7.37: Enter Comments (Process Flow)

25. Enter the comments in the *Specify Comments for process flow customer* field.



26. Click **OK** to save the comments. This displays a screen confirming that the process flow has been created successfully.
27. Exit the Process Designer by clicking the **File** menu and selecting **Exit**.

REGISTERING PROCESS FLOW WITH JMS EVENT

After the Process Flow is created it must be registered with the JMS Event. JMS Event triggers the Process Flow when a message is found on the specified JMS Server. To register the Process Flow with the JMS Event, Event Registry activity is created. Event Registry (**EvalJMSE_EventRegistry**) is used to bind **EvalJMSE_JMS** and **EvalJMSE_ProcessFlow** already created. This section describes how to edit the Event Registry.

Steps to edit the Event Registry

1. In the Adeptia Suite homepage menu, click **[+] Design** to expand the tree. All the items in the **Design** category are displayed.

- Click **[+] Events & Triggers** to expand the tree and then click **Event Registry**. The Manage Event Registry screen is displayed with the list of existing Event Registries (see Figure 7.38).

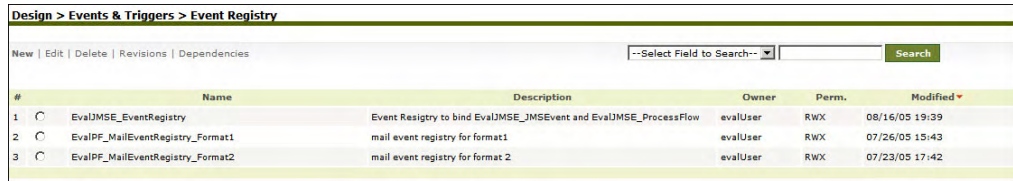

#	Name	Description	Owner	Perm.	Modified
1	<input type="radio"/> EvalJMSE_EventRegistry	Event Registry to bind EvalJMSE_JMSEvent and EvalJMSE_ProcessFlow	evalUser	RWX	08/16/05 19:39
2	<input type="radio"/> EvalPF_MailEventRegistry_Format1	mail event registry for format1	evalUser	RWX	07/26/05 15:43
3	<input type="radio"/> EvalPF_MailEventRegistry_Format2	mail event registry for format 2	evalUser	RWX	07/23/05 17:42

Figure 7.38: Manage Event Registry

- Select the radio button adjacent to *EvalJMSE_EventRegistry* activity and then click **Edit** link. This displays the Edit *EvalJMSE_EventRegistry* activity screen, with properties of the activity displayed in their respective fields (see Figure 7.39).

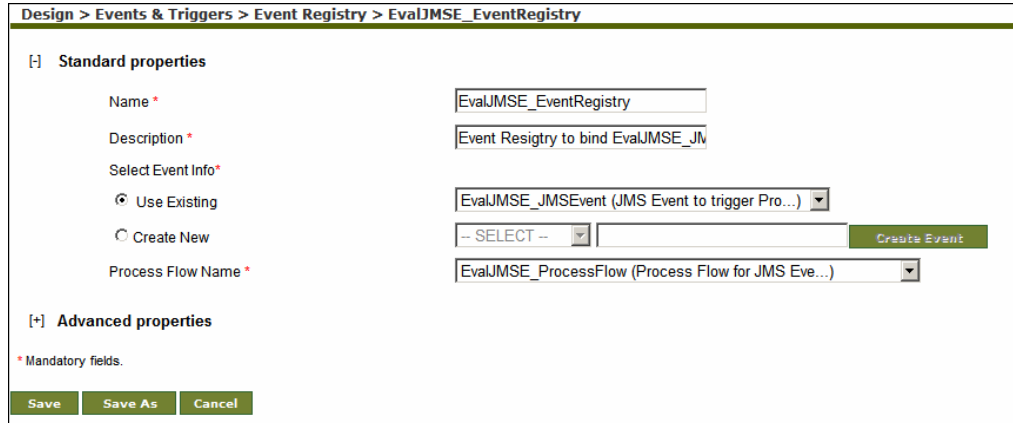

Design > Events & Triggers > Event Registry > EvalJMSE_EventRegistry

Standard properties

Name *

Description *

Select Event Info *

Use Existing

Create New

Process Flow Name *

Advanced properties

* Mandatory fields.

Figure 7.39: Edit *EvalJMSE_Event Registry*

A detailed description of fields on this screen is explicated in the table below.

Table 7.11: Details of Fields on Edit Event Registry Screen

Field Name	Field Description
Name	Name of the Event Registry
Description	Description of the Event Registry
Select Event Info as Existing Event or Create New	Name of the JMS Event, which triggers the Process Flow
Process Flow Name	Name of the Process Flow, which is triggered by JMS Event

- Make the necessary changes.
- Once you have made the required changes, click the **Save** button to save the changes. A screen is displayed confirming that the Event Registry has been updated successfully. If the *comments* property is enabled, then clicking **Save** will display a screen where you need to enter comments related to updating the Event Registry (refer to Figure 7.10).
- Enter the comments in the *Add Comments* field.



The comment should be at least 1 character in length.

7. Click **OK** to save the comments. This displays a screen confirming that the Event Registry has been updated successfully.

8 RECORD TO RECORD SERVICE PROCESS FLOW

This section describes the Record to Record Service Process Flow.

In the Adeptia Suite this process flow is available in:

BPM Suite	Workflow Suite	Integration Suite	ETL Suite
√		√	√

INTRODUCTION

This Process Flow is used to process data of a positional file. Data of the positional file is processed record by record. One record is taken at a time, processed and finally sent to JMS server. After the record is inserted to the JMS server at the target end, an email is sent for acknowledgement and next record is taken for processing. The whole process continues till all the records of positional file at the source end are processed and inserted to the JMS server.

SERVICES USED IN THIS SAMPLE PROCESS FLOW

This sample Process Flow illustrates the use of following services of Adeptia Suite:

- File Source
- Positional Schema
- Record to Record Service
- JMS Target
- Mail Notification
- Process Flow Variable

DESCRIPTION

This sample Process Flow can be outlined as below:

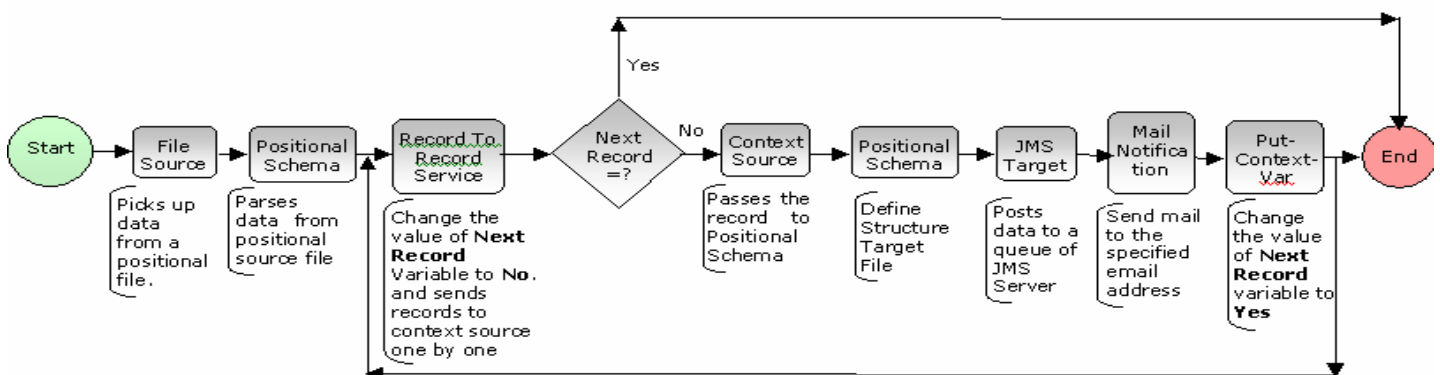

Figure 8.1: Flow Chart to show Process Flow

File Source (EvalRec_FileSource)

File Source activity is used to specify a file, which is stored in local drive, as source. File Source picks up the specified file and passes it to the other activity. In this Process Flow, a positional file is specified as source.

Positional Schema (EvalRec_PositionalSchema)

Positional Schema is used to read data from or write data to a positional file. In this Process Flow two positional schemas are used, one at the source end to read data from the positional source file and the other at the target end to write data to the JMS Target.

Record to Record Service (EvalRec_Record2Record)

Record to Record Service is used to process input data record by record according to the defined Java Script and provide the output data record by record. In this Process Flow, Record to Record service is used to process input data one record at a time and provide the output in a similar fashion.

JMS Target (EvalRec_JMSTarget)

JMS Target is used to publish target data in a topic or to post data in a queue of the JMS server. In this Process Flow JMS Target is used to post the data in a queue of the JMS Server.

Mail Notification (EvalRec_MailNotification)

Mail Notification is used to send mail to users about the execution status of a Process Flow. In this Process Flow mail notification is used to acknowledge the processed records to the users.

USAGE SCENARIO

This Process Flow can be used, whenever you want to process records one by one.

DATA DESCRIPTION

Data used in this Process Flow contains records of employees of different departments of a company. Records of the employees are stored in a positional file.

The structure of the positional file being used as source is displayed in the table below.

Table 8.1: Structure of Positional File used as Source

Field Name	Description	Data Type
NAME	Name of the employee	String
ADDRESS	Address of the employee	String
EMAIL_ID	Email address of the employee	String
PHONE_NO	Phone number of the employee	Number
DOB	Date of Birth of the employee	Date
DEPT	Department of the employee	String
SALARY	Salary of the employee	Number
DOJ	Date of joining of the employee	Date
DESIGNATION	Designation of the employee	String
AGE	Age of the employee	Number

	Name of the fields of the target file are same as shown in the above table.
---	---

PREREQUISITES

- OpenJMS must be installed and running.
- Queue1, which is the default queue for OpenJMS, is used. So make sure that Queue is available in OpenJMS

EXECUTING AND MONITORING

This section describes the execution of sample Process Flow and monitoring Process Flow execution.

Steps to execute the Process Flow:

1. In the Adeptia Suite homepage menu, click **[+] Design** to expand the tree. All the items in the **Design** category are displayed.
2. Click **[+] Process Flow** to expand the tree and then click **Process Flow**. The Manage Process Flow screen is displayed with the list of existing Process Flows (refer to Figure 7.27).
3. Select the radio button adjacent to *EvalRec_ProcessFlow* Process Flow and then click **Execute** link. The View Process Flow Monitor screen is displayed (refer to Figure 3.2).
4. Click the link **Process Flow Logs** to view the status of the Process Flow execution. The Process Flow Logs is displayed (see Figure 8.2).

Reports > Process Flow Log

Search Criteria

Start Date: 10/04/2007 Start Time: 00:00 End Date: 10/04/2007 End Time: 23:59

Process Flow Name: Select All Sort By Name Status: Executed Details Summary

Activity Name	Activity Type	Status	UserID	Start Time	End Time	Action
EvalRec_Notification	MailNotification	Executed	admin	10/04/2007 17:56:11	10/04/2007 17:56:14	Details Repository Summary
EvalRec_Notification	MailNotification	Running	admin	10/04/2007 17:56:11	NA	Details Repository Summary Context Info
EvalRec_JMSTarget	JmsTarget	Executed	admin	10/04/2007 17:56:07	10/04/2007 17:56:08	Details Repository Summary
EvalRec_JMSTarget	JmsTarget	Running	admin	10/04/2007 17:56:07	NA	Details Repository Summary Context Info
EvalRec_PositionalSchema1	SchemaIntermediate2StreamTransformer	Executed	admin	10/04/2007 17:56:06	10/04/2007 17:56:07	Details Repository Summary
EvalRec_PositionalSchema1	SchemaIntermediate2StreamTransformer	Running	admin	10/04/2007 17:56:06	NA	Details Repository Summary Context Info
RecordData	ContextSource	Executed	admin	10/04/2007 17:56:06	10/04/2007 17:56:06	Details Repository Summary
RecordData	ContextSource	Running	admin	10/04/2007 17:56:06	NA	Details Repository Summary Context Info
EvalRec_Notification	MailNotification	Executed	admin	10/04/2007 17:55:52	10/04/2007 17:55:56	Details Repository Summary
EvalRec_Notification	MailNotification	Running	admin	10/04/2007 17:55:52	NA	Details Repository Summary Context Info
EvalRec_JMSTarget	JmsTarget	Executed	admin	10/04/2007 17:55:51	10/04/2007 17:55:52	Details Repository Summary
EvalRec_JMSTarget	JmsTarget	Running	admin	10/04/2007 17:55:51	NA	Details Repository Summary Context Info
EvalRec_PositionalSchema1	SchemaIntermediate2StreamTransformer	Executed	admin	10/04/2007 17:55:50	10/04/2007 17:55:51	Details Repository Summary
EvalRec_PositionalSchema1	SchemaIntermediate2StreamTransformer	Running	admin	10/04/2007 17:55:50	NA	Details Repository Summary Context Info
RecordData	ContextSource	Executed	admin	10/04/2007 17:55:50	10/04/2007 17:55:50	Details Repository Summary
RecordData	ContextSource	Running	admin	10/04/2007 17:55:50	NA	Details Repository Summary Context Info
EvalRec_Record2Record	ScriptedRecord2RecordTransformer	Running	admin	10/04/2007 17:55:50	NA	Details Repository Summary Context Info
EvalRec_Record2Record	ScriptedRecord2RecordTransformer	Executed	admin	10/04/2007 17:55:49	10/04/2007 17:55:50	Details Repository Summary
EvalRec_PositionalSchema	SchemaStream2IntermediateTransformer	Running	admin	10/04/2007 17:55:49	NA	Details Repository Summary Context Info
EvalRec_PositionalSchema	SchemaStream2IntermediateTransformer	Executed	admin	10/04/2007 17:55:49	10/04/2007 17:55:49	Details Repository Summary
EvalRec_FileSource	FileSource	Running	admin	10/04/2007 17:55:49	NA	Details Repository Summary Context Info
EvalRec_FileSource	FileSource	Executed	admin	10/04/2007 17:55:49	10/04/2007 17:55:49	Details Repository Summary
EvalRec_ProcessFlow	Transaction	Running	admin	10/04/2007 17:55:49	NA	Details Repository Summary Context Info

Figure 8.2: View Process Flow Logs

 To view the summary of all instances of the process flow execution, click the **Summary** button.

- Click **Details** under the **Action** column of the activity of which you want to view execution details. This displays the Detailed Process Flow Activity Execution screen (see Figure 8.3).

Process Flow Log Details

Process Flow Name : EvalRec_ProcessFlow
Process Flow PID : 192168001007119150074895500996

Date/Time	Activity Name	Activity Type	Status	Message	Level
10/04/2007 17:56:40	EvalRec_ProcessFlow	Transaction	Executed	Activity disposed. Start Time:2007-10-04 17:55:49 End Time:2007-10-04 17:56:40 Run Time:51 second(s) 253 ms	INFO services/ se(Abstra
10/04/2007 17:56:40	EvalRec_ProcessFlow	Transaction	Running	Context Information: {TransactionAddress=localhost://Indigo.Transaction[192168001168112384188731200001! 192168001007119150074895500996],type=Transaction,name=EvalRec_ProcessFlow,id=192168001168112384188731200001,pid=192168001007119150074895500996,currentState=state-BPMN:TASK:BASIC_TASK-190645,nextRecord=yes,LoggingLevel=INFO,RecordData={NAME=[NAME], ADDRESS=25-street?[ADDRESS], EMAIL_ID=seawatch@snet.net[EMAIL_ID], PHONE_NO=75995[PHONE_NO], DOB=-654672600000 [DOB], DEPT=testing[DEPT], SALARY=2490[SALARY], DOJ=581625000000[DOJ], DESIGNATION=Trainee [DESIGNATION], AGE=34[AGE]}}	INFO services/ se(Abstra
10/04/2007 17:56:31	EvalRec_Record2Record	ScriptedRecord2RecordTransformer	Executed	Activity disposed. Start Time:2007-10-04 17:55:50 End Time:2007-10-04 17:56:31 Run Time:41 second(s) 69 ms. Operation count:3 Records Average:0.0730478 operations/sec	INFO services/ se(Abstra
10/04/2007 17:56:30	EvalRec_Notification	MailNotification	Executed	Activity disposed. Start Time:2007-10-04 17:56:27 End Time:2007-10-04 17:56:30 Run Time:3 second(s) 766 ms	INFO services/ se(Abstra
10/04/2007 17:56:30	EvalRec_Notification	MailNotification	Running	Execute	INFO services/ te(Abstra
10/04/2007 17:56:27	EvalRec_Notification	MailNotification	Running	Initialize	INFO services/ alize(Abst
10/04/2007 17:56:27	EvalRec_JMSTarget	JmsTarget	Executed	Activity disposed. Start Time:2007-10-04 17:56:26 End Time:2007-10-04 17:56:27 Run Time:1 second(s) 81 ms	INFO services/ se(Abstra
10/04/2007 17:56:26	EvalRec_JMSTarget	JmsTarget	Running	Execute	INFO services/ te(Abstra
10/04/2007 17:56:26	EvalRec_JMSTarget	JmsTarget	Running	Initialize	INFO services/ alize(Abst

Activity disposed. Start Time:2007-10-04 17:56:25 End Time:2007-10-04 17:56:25 Run Time:1 second(s) 81 ms

Close Window

Figure 8.3: View Process Flow Log Details

EDITING ACTIVITIES

Activities used in this sample Process Flow are pre-created. This section describes how to edit these activities.

File Source

(EvalRec_FileSource)

File Source activity is used to specify a file, which is stored in local drive, as source. File Source picks up the specified file and passes it to the other activity. In this Process Flow a positional file (**EvalRecPositionalFile.txt**) is specified as source. This file is stored in `../../Solutions/Demo/EvalRec/` directory.

Steps to edit the File Source:

1. In the Adeptia Suite homepage menu, click **[+] Configure** to expand the tree. All the items in the **Configure** category are displayed.
2. Click **[+] Services** to expand the tree. All the items in the **Services** category are displayed.
3. Click **[+] Source** to expand the tree, and then click **File**. The Manage File Source screen is displayed with the list of existing File Source activities (refer to Figure 4.4).
4. Select the radio button adjacent to *EvalRec_FileSource* activity and then click **Edit** link. This displays the Edit *EvalRec_FileSource* activity screen, with the properties of the activity displayed in their respective fields (see Figure 8.4).

Configure > Services > Source > File > EvalRec_FileSource

[-] Standard properties

Name *	<input type="text" value="EvalRec_FileSource"/>
Description *	<input type="text" value="Positional File"/>
File Path *	<input type="text" value=".\Solutions\Demo\EvalRec"/>
File Name *	<input type="text" value="EvalRecPositionalFile.txt"/>

[+] Advanced properties

* Mandatory fields.

Save
Save As
Cancel
Test

Figure 8.4: Edit *EvalRec_File Source* Activity

A detailed description of fields on this screen is explicated in the table below.

Table 8.2: Details of Fields on Edit File Source Screen

Field Name	Field Description
Name	Name of the File Source
Description	Description of the File Source
File Path	Path of the source file. For example: <code>../../../../Solutions/Demo/EvalRec/</code>
File Name	Name of the source file. For example: <code>EvalRecFileSource.txt</code>

5. Make the necessary changes.
6. Once you have made the required changes, click the **Save** button to save the changes. A screen is displayed confirming that the File Source Activity has been updated successfully. If the *comments* property is enabled, then clicking **Save** will display a screen where you need to enter comments related to updating the file source (refer to Figure 7.10).
7. Enter the comments in the *Add Comments* field.

	The comment should be at least 1 character in length.
---	---

8. Click **OK** to save the comments. This displays a screen confirming that the file source has been updated successfully.

	You can verify the file source activity at design time. For this, click Test Connection . This verifies the values in the <i>File Path</i> and <i>Filename</i> fields and checks whether the file actually exists in the specified location.
---	---

Editing Positional Schema (EvalRec_PositionalSchema)

Positional Schema is used to read data from or write data to a positional file. In this Process Flow same positional schema is used in two places, one at the source end to read data from the positional source file and the other at the target end to write data to the JMS Target.

Steps to edit the Positional Schema:

1. In the Adeptia Suite homepage menu, click **[+] Configure** to expand the tree. All the items in the **Configure** category are displayed.
2. Click **[+] Services** to expand the tree. All the items in the **Services** category are displayed.
3. Click **[+] Schema** to expand the tree, and then click **Positional**. The Manage Positional Schema screen is displayed with the list of existing Positional Schema activities (see Figure 8.5).

Configure > Services > Schema > Positional					
#	Name	Description	Owner	Perm.	Modified
1	<input type="radio"/> EvalRec_PositionalSchema	Positional Schema	demouser	RWX	08/16/05 15:23

Figure 8.5: Manage Positional Schema

4. Select the radio button adjacent to *EvalRec_PositionalSchema* activity and then click **Edit** link. This displays the Edit *EvalRec_PositionalSchema* activity screen, with the properties of the activity displayed in their respective fields (see Figure 8.6).

Configure > Services > Schema > Positional > EvalRec_PositionalSchema										
[-] Standard properties										
Name *	EvalRec_PositionalSchema									
Description *	Positional Schema									
Data Header Present	<input checked="" type="checkbox"/>									
Download Schema Definition File	<input type="button" value="Download"/>									
Create Schema Definition* Using	<input type="radio"/> Field Length <input checked="" type="radio"/> Start & End Positions									
<input type="radio"/> Use Definition File	XSD									<input type="button" value="Upload File"/>
<input checked="" type="radio"/> Enter the Fields Sequentially										
#	FieldName	Description	Type	DateFormat	TimeFormat	Start	End	Length	Align	Skip
1	NAME		string	mmddyyyy	hh:mm:ss	1	25	25	L	<input type="checkbox"/>
2	ADDRESS		string	mmddyyyy	hh:mm:ss	26	42	17	L	<input type="checkbox"/>
3	EMAIL_ID		string	mmddyyyy	hh:mm:ss	43	67	25	L	<input type="checkbox"/>
4	PHONE_N		number	mmddyyyy	hh:mm:ss	68	89	22	L	<input type="checkbox"/>
Number of Rows		1	at Position		11	<input type="button" value="Add Row"/>		<input type="button" value="Remove Row"/>		
[+] Advanced properties										
* Mandatory fields.										
<input type="button" value="Save"/>		<input type="button" value="Save As"/>		<input type="button" value="Cancel"/>		<input type="button" value="Test"/>				

Figure 8.6: Edit *EvalRec_PositionalSchema* Activity

A detailed description of fields on this screen is explicated in the table below.

Table 8.3: Details of Fields on Edit Positional Schema Screen

Field Name	Field Description
Name	Name of the Positional Schema
Description	Description of the Positional Schema
Data Header Present	Data Header contains the titles of the fields in positional file. If data header is present in the positional file, check the Data Header Present checkbox.
Download	To download existing schema definition file click Download button.

Schema Definition File	Else, you can create a new schema definition.						
Create Schema Definition	<p>Schema can be defined using one of the following options:</p> <ul style="list-style-type: none"> ▪ Use Definition File ▪ Enter the Field Sequentially <p>Pre-created schema with this sample Process Flow is created using second option i.e. Enter the Field Sequentially</p>						
Field Name	Name of the Fields						
Type	<p>There are three data types:</p> <table border="0"> <tr> <td>String</td> <td>String can be used for any type of data.</td> </tr> <tr> <td>Number</td> <td>Contains numbers</td> </tr> <tr> <td>Date</td> <td>Contains Date and Time</td> </tr> </table>	String	String can be used for any type of data.	Number	Contains numbers	Date	Contains Date and Time
String	String can be used for any type of data.						
Number	Contains numbers						
Date	Contains Date and Time						
Start Position	Start position of the field						
End Position	End position of the field						
Length	Length of the field						
Alignment	<p>Alignment of the Filed</p> <p>L if the field is left aligned. R if the field is right aligned.</p>						
Skip	Skip the field while parsing the data from source file to XML						

5. Make the necessary changes.
6. Once you have made the required changes, click the **Save** button to save the changes. A screen is displayed confirming that the Positional Schema activity has been updated successfully. If the *comments* property is enabled, then clicking **Save** will display a screen where you need to enter comments related to updating the Positional Schema activity (refer to Figure 7.10).
7. Enter the comments in the *Add Comments* field.

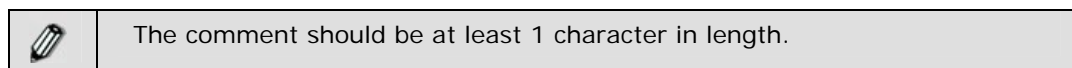

8. Click **OK** to save the comments. This displays a screen confirming that the Positional Schema activity has been updated successfully.

Testing Positional Schema (EvalRec_PositionalSchema)

You can verify the positional schema activity at design time.

Steps to verify schema activity

1. Click **Test** button on the Edit Positional Schema screen. The Test Schema screen is displayed (refer to Figure 7.14).
2. Select the type of schema to test, from the *Type* drop-down list. By default, *Source* is selected.

3. Enter the full path (with file name and extension) of the source file in the *Source File Name* field.
4. Enter the full path of the XML target file, where it will be generated, in the *Target File Name* field.



If you want to test this schema for the target end, select *Target* from the *Type* drop-down list. Now the source file will be an XML file that is generated by the mapping activity used in the process flow and target file will be the full path (with file name and extension) of target file.

5. Enter the full path of the XML file where errors will be stored, in the *Error File Name* field.
6. Click **Submit** button. This tests the validity of the positional schema.

Editing Record to Record Service (EvalRec_Record2Record)

Record to Record Service is used to process input data record by record according to the defined Java Script and provide the output data record by record. In this Process Flow Record to Record service is used to process input data one record at a time and provide the output in a similar fashion. Sample Java Code used in the scripted service is displayed in Figure 8.7.

```
// Setting Process Flow variable (nextRecord) value
context.put("nextRecord","no");

// Setting one record into Process Flow Context
context.put("RecordData",record);

// Wait for Process Flow variable(nextRecord) value to be changed to 'yes'
while(true)
{
    try
    {
        String recordExist = (String)context.get("nextRecord");

        if(recordExist.equalsIgnoreCase("no"))
        {
            Thread.sleep(1000);
        }
        else
        {
            break;
        }
    }
    catch (InterruptedException e)
    {
        e.printStackTrace();
    }
}
```

Figure 8.7: Sample JAVA Code

Steps to edit the Record to Record Service:

1. In Adeptia Suite homepage menu, click **[+] Configure** to expand the tree. All the items in the **Configure** category are displayed.
2. Click **[+] Services** to expand the tree. All the items in the **Services** category are displayed.
3. Click **[+] Data Transform** to expand the tree, and then click **Record to Record**. The Manage Record to Record screen is displayed with the list of existing Record to Record activities (see Figure 8.8).

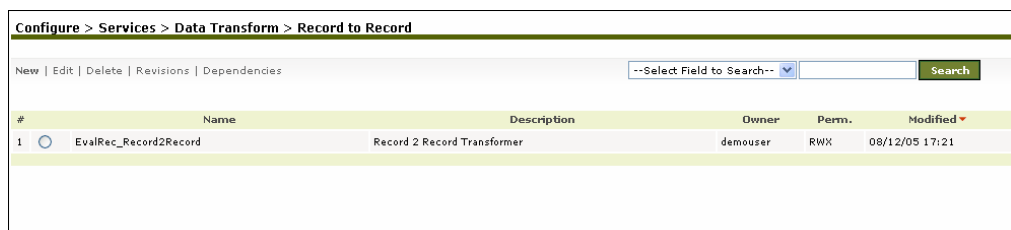

#	Name	Description	Owner	Perm.	Modified
1	EvalRec_Record2Record	Record 2 Record Transformer	demouser	RWX	08/12/05 17:21

Figure 8.8: Manage Record to Record

4. Select the radio button adjacent to *EvalRec_Record2Record Service* activity and then click **Edit** link. This displays the Edit *EvalRec_Record2Record Service* activity screen, with the properties of the activity displayed in their respective fields (see Figure 8.9).

Configure > Services > Data Transform > Record to Record > EvalRec_Record2Record

[+] Standard properties

Name *

Description *

Script *

```
// Setting one record into process flow context
context.put("RecordData",record);

// Wait for Process Flow variable(nextRecord) value to be changed to 'yes'
{
  try
  {
    String recordExist = (String)context.get("nextRecord");

    if(recordExist.equalsIgnoreCase("no"))
    {
      Thread.sleep(1000);
    }
    else
    {
      break;
    }
  }
  catch (InterruptedException e)
  {
    e.printStackTrace();
  }
}
```

Input Format *

Schema Name (Input data) *

Output Format *

[+] Advanced properties

* Mandatory fields.

Figure 8.9: Edit *EvalRec_Record2Record* Activity

A detailed description of fields on this screen is explicated in the table below.

Table 8.4: Details of Fields on Edit Record to Record Screen

Field Name	Field Description
Name	Name of the Record to Record activity
Description	Description of the Record to Record activity
Script	Java Code that you want to run to process the records
Input Format	Format of the input data whether Native or XML
Output Format	Format of the output data whether Native or XML
Schema Name	Name of the Schema activity used to parse the data

5. Make the necessary changes.
6. Once you have made the required changes, click the **Save** button to save the changes. A screen is displayed confirming that the Record to Record Service activity has been updated successfully. If the *comments* property is enabled, then clicking **Save** will display a screen where you need to enter comments related to updating the Record to Record Service activity (refer to Figure 7.10).
7. Enter the comments in the *Add Comments* field.

 The comment should be at least 1 character in length.

- Click **OK** to save the comments. This displays a screen confirming that the Record to Record Service activity has been updated successfully.

Editing JMS Provider (EvalRec_JMSProvider)

JMS Provider is used to connect to JMS Server. While creating JMS Provider, you need to specify the Provider Jar files, which are used to connect to JMS server. JMS Event further uses JMS Provider. This should be noted that JMS Provider does not directly take part in the creation of Process Flow. It just helps the JMS Target to connect to the JMS Server.

Steps to edit JMS Provider:

- In Adeptia Suite homepage menu, click **[+] Configure** to expand the tree. All the items in the **Configure** category are displayed.
- Click **[+] Services** to expand the tree and then click **[+] Connector**. All the items in the **Connector** category are displayed.
- Click **JMS Provider**. The Manage JMS Provider screen is displayed with the list of existing JMS Providers (refer to Figure 7.8).
- Select the radio button adjacent to *EvalRec_JMSProvider* activity and then click **Edit** link. This displays the Edit *EvalRec_JMSProvider* activity screen, with the properties of the activity displayed in their respective fields (see Figure 8.10).

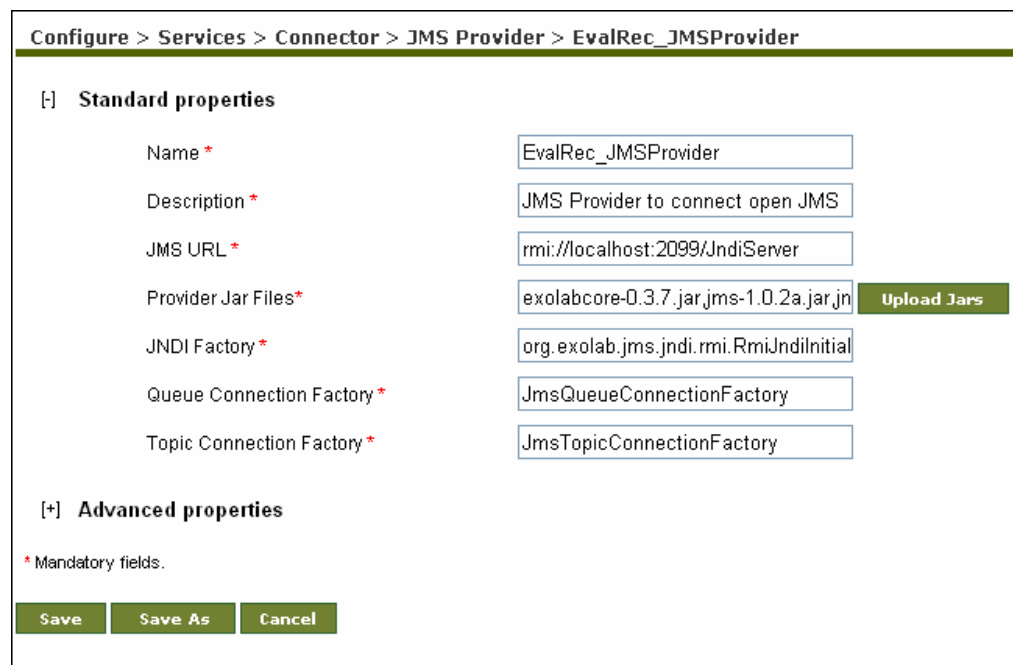

Configure > Services > Connector > JMS Provider > EvalRec_JMSProvider

[+] Standard properties

Name *	EvalRec_JMSProvider
Description *	JMS Provider to connect open JMS
JMS URL *	rmi://localhost:2099/JndiServer
Provider Jar Files*	exolabcore-0.3.7.jar,jms-1.0.2a.jar,jn Upload Jars
JNDI Factory *	org.exolab.jms.jndi.rmi.RmiJndiInitial
Queue Connection Factory *	JmsQueueConnectionFactory
Topic Connection Factory *	JmsTopicConnectionFactory

[+] Advanced properties

* Mandatory fields.

Save Save As Cancel

Figure 8.10: Edit *EvalRec_JMS Provider* Activity

A detailed description of fields on this screen is explicated in the table below.

Table 8.5: Details of Fields on Edit JMS Provider Screen

Field Name	Field Description
Name	Name of the JMS Provider
Description	Description of the JMS Provider
JMS URL	URL of the JMS Server
Provider Jar Files	Jar files, which are used to connect to JMS servers. Click Upload Jars button to browse and upload Jar files.
JNDI Factory	The factory name used to access the external JMS JNDI name service.
Queue Connection Factory	Queue connection factory is used to create connections to the associated JMS provider of JMS queues, for point-to-point messaging.
Topic Connection Factory	JMS topic connection factory is used to create connections to the associated JMS provider of JMS topics, for publish/subscribe messaging.

5. Make the necessary changes.
6. Once you have made the required changes, click the **Save** button to save the changes. A screen is displayed confirming that the JMS Provider has been updated successfully. If the *comments* property is enabled, then clicking **Save** will display a screen where you need to enter comments related to updating the JMS Provider (refer to Figure 7.10).
7. Enter the comments in the *Add Comments* field.

	The comment should be at least 1 character in length.
---	---

8. Click **OK** to save the comments. This displays a screen confirming that the JMS Provider has been updated successfully.

	JMS provider, pre-created with the Adeptia Suite, is configured for OpenJMS server. If you want to use another JMS server, load appropriate Provider Jar files and change other parameters.
---	---

Editing JMS Target (EvalRec_JMSTarget)

JMS Target is used to publish target data in a topic or to post data in a queue of the JMS server. In this Process Flow JMS Target is used to post the data in a queue of the JMS Server.

Steps to edit the JMS target:

1. In the Adeptia Suite homepage menu, click **[+] Configure** to expand the tree. All the items in the **Configure** category are displayed.
2. Click **[+] Services** to expand the tree. All the items in the **Services** category are displayed.

- Click **[+] Target** to expand the tree, and then click **JMS**. The Manage JMS Target screen is displayed with a list of existing JMS Target activities (see Figure 8.11).

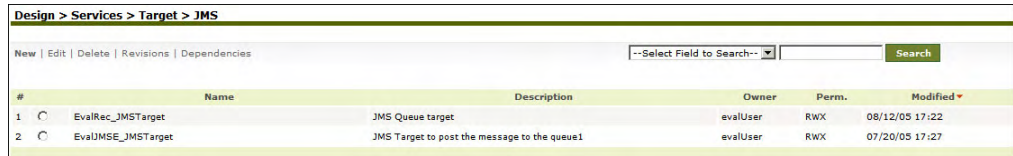

#	Name	Description	Owner	Perm.	Modified
1	EvalRec_JMSTarget	JMS Queue target	evalUser	RWX	08/12/05 17:22
2	EvalJMSE_JMSTarget	JMS Target to post the message to the queue1	evalUser	RWX	07/20/05 17:27

Figure 8.11: Manage JMS Target

- Select the radio button adjacent to *EvalRec_JMSTarget* activity and then click **Edit** link. This displays the Edit *EvalRec_JMSTarget* activity screen, with the properties of the activity displayed in their respective fields (see Figure 8.12).

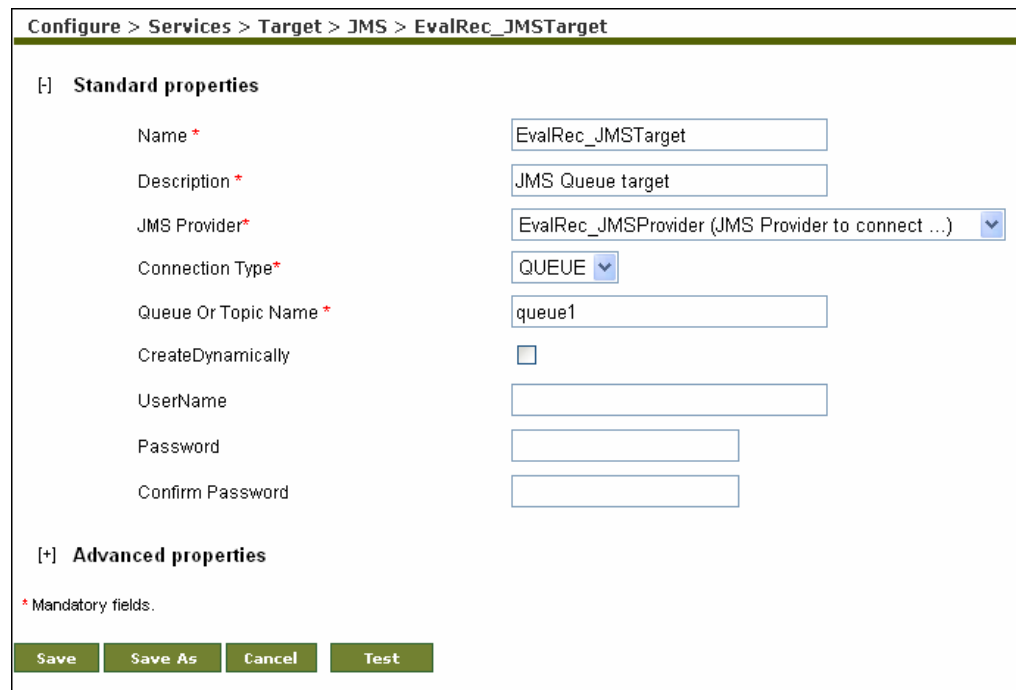

Configure > Services > Target > JMS > EvalRec_JMSTarget

[-] Standard properties

Name *

Description *

JMS Provider*

Connection Type*

Queue Or Topic Name *

CreateDynamically

UserName

Password

Confirm Password

[+] Advanced properties

* Mandatory fields.

Figure 8.12: Edit *EvalRec_JMSTarget* Activity

A detailed description of fields on this screen is explicated in the table below.

Table 8.6: Details of Fields on Edit JMS Target Screen

Field Name	Field Description
Name	Name of the JMS Target activity
Description	Description of the JMS Target Activity
JMS Provider	JMS Provider used to connect to JMS Server. For more details, refer to the section Editing JMS Provider .
Connection Type	JMS Connection type, either TOPIC or QUEUE

	<p>TOPIC Used for one to many messaging. It supports publish subscribe model of messaging.</p> <p>QUEUE Used for one-to-one messaging. It supports Point-to-Point Messaging.</p>
Queue or Topic Name	Name of the Queue or Topic from which JMS Event receives data
Create Dynamically	Creates Queue or Topic specified above if it does not already exist in the specified JMS Server
Username	Username required to connect to JMS Server
Password	Password required to connect to JMS Server
Confirm Password	Re-enter the Password

5. Make the necessary changes.
6. Once you have made the required changes, click the **Save** button to save the changes. A screen is displayed confirming that the JMS Target Activity has been updated successfully. If the *comments* property is enabled, then clicking **Save** will display a screen where you need to enter comments related to updating the JMS target (refer to Figure 7.10).
7. Enter the comments in the *Add Comments* field.

 The comment should be at least 1 character in length.

8. Click **OK** to save the comments. This displays a screen confirming that the JMS target has been updated successfully.

 You can verify the JMS target activity at design time. For this, click **Test Connection**.

Editing Mail Notification Activity

(EvalRec_MailNotification)

Mail Notification is used to send mail to users about the execution status of a Process Flow. In this Process Flow mail notification is used to acknowledge the processed records to the users.

Steps to edit Mail Notification:

1. In the Adeptia Suite homepage menu, click **[+] Configure** to expand the tree. All the items in the **Configure** category are displayed.
2. Click **[+] Services** to expand the tree. All the items in the **Services** category are displayed.
3. Click **[+] Miscellaneous** to expand the tree, and then click **Mail Notification**. The Manage Mail Notification screen is displayed with a list of existing Mail Notification activities (see Figure 8.13).

Configure > Services > Miscellaneous > Mail Notification

New | Edit | Delete | Revisions | Dependencies

--Select Field to Search--

#	Name	Description	Owner	Perm.	Modified
1	<input type="radio"/> PurchaseOrderProcessingNotify	notify when transaction finishes	demouser	RWX	09/01/09 12:29
2	<input type="radio"/> FulfillmentErrorNotify	notify when web service call fails	demouser	RWX	09/01/09 12:29
3	<input type="radio"/> NotifyPurchaseDepartment	notify purchase dept of new order	demouser	RWX	09/01/09 12:29
4	<input type="radio"/> EvalRec_MailNotification	Mail Notification to acknowledge the record processed	demouser	RWX	08/22/05 15:17

Figure 8.13: Manage Mail Notification

- Select the radio button adjacent to *EvalRec_MailNotification* activity and then click **Edit** link. This displays the Edit *EvalRec_MailNotification* activity screen, with the properties of the activity displayed in their respective fields (see Figure 8.14).

Configure > Services > Miscellaneous > Mail Notification > EvalRec_MailNotification

[-] Standard properties

Name *

Description *

Notification Type*

Mail Subject*

To User(s)

To Email-Id(s) (comma separated)

Message

Notification Criteria

Attachment

File Path

File Name

[+] Advanced properties

* Mandatory fields.

Figure 8.14: Edit *EvalRec_MailNotification* Activity

A detailed description of fields on this screen is explicated in the table below.

Table 8.7: Details of Fields on Edit Mail Notification Screen

Field Name	Field Description
Name	Name of the Mail Notification
Description	Description of the Mail Notification
Notification Type	There are two types of Mail Notification: <ul style="list-style-type: none"> User Defined Process Flow Summary In this Process Flow, User Defined notification type is selected.
Mail Subject	Enter the subject of the mail, which is sent to specified email address
To Adeptia User(s)	Select user(s) to whom you want to send notification email. You can either select user(s) or you can specify email Id(s) in the <i>To Email-Id(s)</i> field.
To Email-Id(s) (comma separated)	Email address(s) of the recipient (s)
Message	Message that is send with the mail
Notification Criteria	There are three types of Notification Criteria: <ul style="list-style-type: none"> Running or Executed Successfully Failure Always Notification criteria are only applicable, when the Notification Type is Process Flow Summary.
Attachment	If Attachment checkbox is enabled, the specified Message is send as attachment of the mail
File Path	Path of the file in case Attachment checkbox is enabled
File Name	Name of the file incase Attachment checkbox is enabled

- Make the necessary changes.
- Once you have made the required changes, click the **Save** button to save the changes. A screen is displayed confirming that the Mail Notification Activity has been updated successfully. If the *comments* property is enabled, then clicking **Save** will display a screen where you need to enter comments related to updating the Mail Notification activity (refer to Figure 7.10).
- Enter the comments in the *Add Comments* field.

	The comment should be at least 1 character in length.
---	---

- Click **OK** to save the comments. This displays a screen confirming that the Mail Notification activity has been updated successfully.



CREATING PROCESS FLOW

(EvalRec_ProcessFlow)

Process Flow is the set of activities arranged in a sequence to perform a specific task(s). Process Flow is created by combining various activities such as Source, Target, Schema or Transformer activities in a logical sequence. Process Designer is used to create a Process Flow. Process Designer has list of activities created. You only need to arrange them in a logical sequence and connect them with BPMN Flows.

Steps to create EvalRec_ProcessFlow:

- In the Adeptia Suite homepage menu, click **[+] Design** to expand the tree. All the items in the **Design** category are displayed.
- Click **[+] Process Flow** to expand the tree and then click **Process Flow**. The Manage Process Flow screen is displayed with the list of existing Process Flows (refer to Figure 7.27).
- Click the **New** link. The Create Process Flow screen is displayed (refer to Figure 7.28).
- Enter the name and the description of the new Process Flow in the *Name* and *Description* fields respectively.
- Select the logging level from the *Logging Level* drop-down list. There are four level of logging. They are described in Table 7.9.
- Select repository file retention from the *Repository File Retention* option. During execution Process Flow creates a temporary repository file to store the intermediate data. These repository files can cause unnecessary disk space usage and you may want to delete them after execution of the Process Flow. On the other hand sometime these repository files can be helpful in case of failure of Process Flow execution. For each instance of the Process Flow execution a unique repository folder is created that contains Source, intermediate XML data files and target formatted data. By default repository files are being stored in the repository folder of the Adeptia Suite. You can also choose an option to delete them or to archive them in a different location. There are four options for the Repository File Retention. They are described in Table 7.10.
- Click the **Process Designer** button to open Process Designer. The Process Designer Screen is displayed (refer to Figure 7.29).
- Once the Process Designer screen is displayed, a message to synchronize the list of activities and Process Flow with the Adeptia Suite is displayed. Click **OK** to synchronize.

	Alternately, you can synchronize the list of activities and Process Flow with the Adeptia Suite by clicking the Synchronize () button displayed on the Tool Bar.
---	--

9. Click **[+] Activities** in Repository View, to expand the list of services and then click **[+] Source**. All the items in the **Source** category are displayed.
10. Click **[+] File Source**. A list of existing File Source activities is displayed.
11. Select **EvalRec_FileSource** and drag it to the Graph Canvas Area (see Figure 8.15).

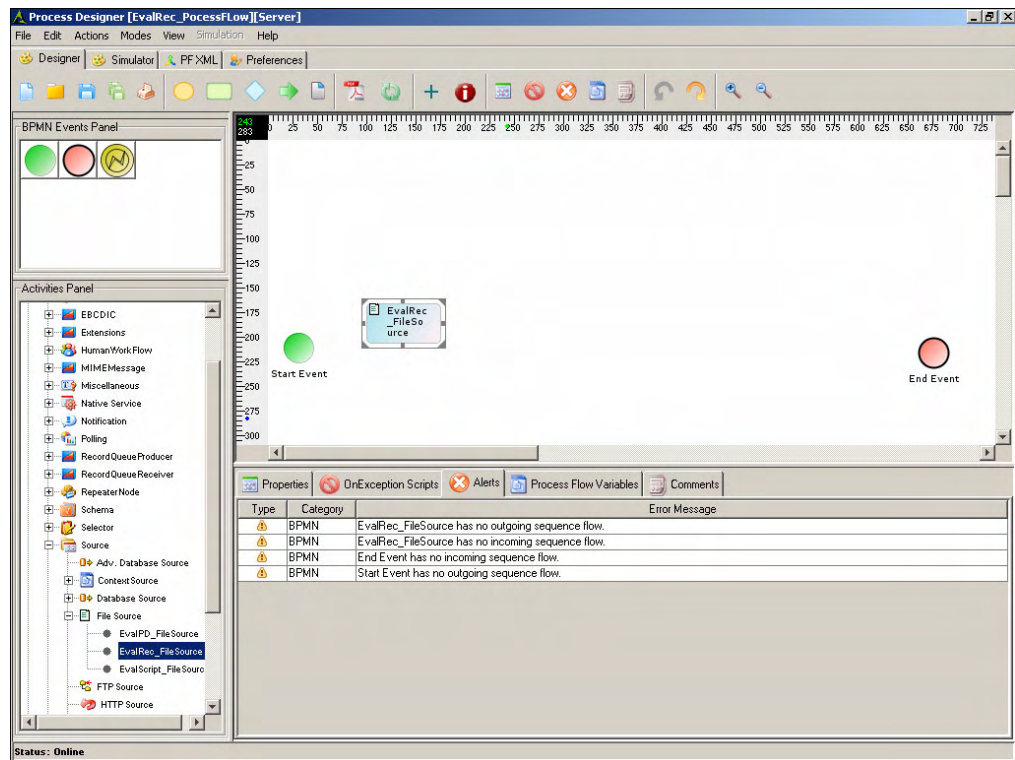

Figure 8.15: Select File Source Activity

12. Similarly, click **[+] Schema** and then **[+] Positional Schema**. Select **EvalRec_PositionalSchema** activity and drag it to the Graph Canvas Area.
13. Click **[+] Datatransform** and then **[+] Record to Record**. Select **EvalRec_Record2Record** activity and drag it to the Graph Canvas Area.
14. To select a BPMN Gateway, click the **BPMN Gateway** () icon in the Palette and drag it to the Graph Canvas Area (see Figure 8.16). In this Process Flow, Gateway is used to check the value of *NextRecord* variable and to decide which path to choose.



Figure 8.16: Drag BPMN Gateway to Graph Canvas Area

15. To create Process Flow Variable, click *Process Flow Variables* tab in the bottom pane. The *Process Flow Variables* panel is displayed in bottom pane. (see Figure 8.17)

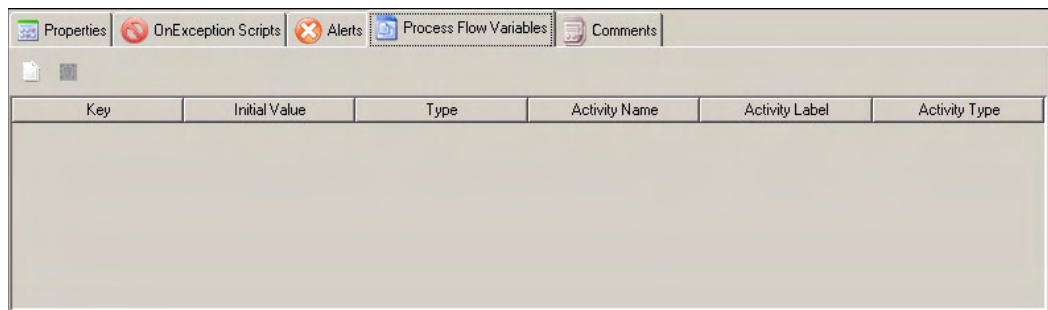



Figure 8.17: Process Flow Variables Panel

16. Click **New Process Flow Variable** () button. The Process flow variable entry dialog box is displayed (see Figure 8.18).

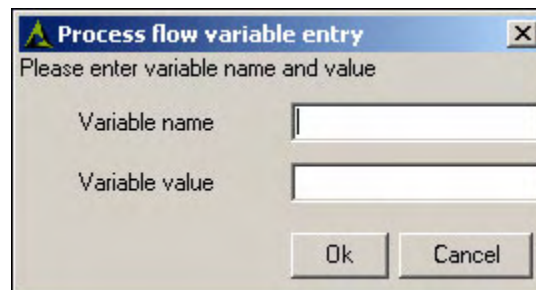

Figure 8.18: Create Process Flow Variable

17. Enter *RecordData* in the *Variable Name* field and click **Ok**. A process flow variable with name *RecordData* is created.
18. Similarly create another process flow variable with name *next Record* with the variable value *yes*.
19. Click **[+] Source** in Repository View, to expand the list of Source activities.
20. Click **[+] Context Source** activity to expand the Context Source activity. The Context Source node is displayed.
21. Drag the Context Source node to the Graph Canvas Area (see Figure 8.19).

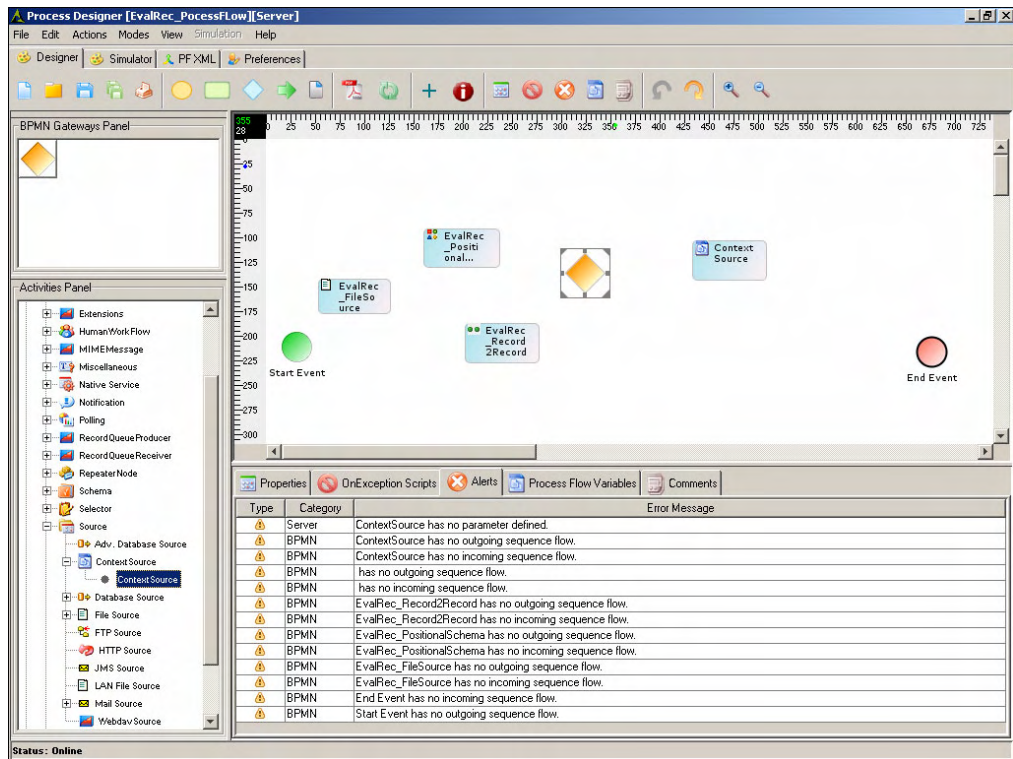

Figure 8.19: Drag Context Source to Graph Canvas Area

- Right-click the context source variable and select **View Properties**. Properties of the context source variable are displayed in the Bottom Pane (see Figure 8.20).

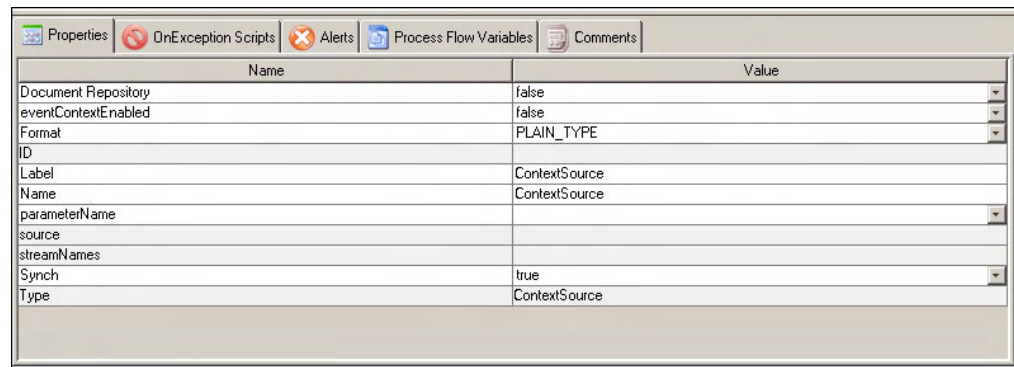

Figure 8.20: Drag Context Source to Graph Canvas Area

- Change the Name and Label of the context source as *RecordData*.
- Select *RecordData* from the *parameterName* drop-down list (see Figure 8.21).

Name	Value
Document Repository	false
eventContextEnabled	false
Format	RECORD_TYPE
ID	
Label	RecordData
Name	RecordData
parameterName	RecordData
source	
streamNames	RecordData
Synch	true
Type	ContextSource

Figure 8.21: Enter Context Source Name

- Click **[+] Schema** and then **[+] Positional Schema**. Select **EvalRec_PositionalSchema** activity and drag it to the Graph Canvas Area. The Change Activity name dialog box is displayed (see Figure 8.22).

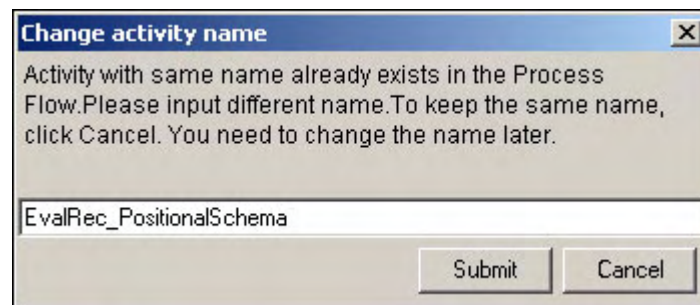



Figure 8.22: Change Activity Name

- Enter **EvalRec_PositionalSchema1** and click the **Submit** button. The *EvalRec_PositionalSchema* activity is displayed in the Graph Canvas Area.
- Click **[+] Target** and then **[+] JMS Target**. Select **EvalRec_JMSTarget** activity and drag it to the Graph Canvas Area.
- Click **[+] Notification** and then **[+] Mail Notification**. Select **EvalRec_MailNotification** activity and drag it to the Graph Canvas Area.
- Click **[+] Action** in the Repository View, to expand the list of Actions.

An Action name is always unique.

- Select **Put-Context-Var** and drag it to the Graph Canvas Area (see Figure 8.23).

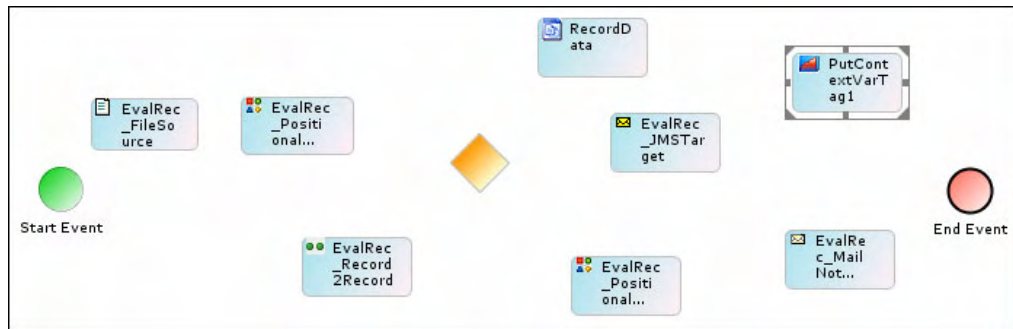

Figure 8.23: Select Put-Context -Var

31. Right-click **Put-Context-Var** in the Graph Canvas Area, and select **View Properties**. Properties of *Put-Context-Var* are shown in the Properties Panel (see Figure 8.24).

Properties		OnException Scripts	Alerts	Process Flow Variables	Comments
Name	Value				
Context Variables					
Label	PutContextVarTag1				
Name	PutContextVarTag1				
Type	Put-Context-Var				

Figure 8.24: View Properties of Put-Context-Var

32. Click *Edit* from the value field of the *context Variable* properties. The Edit Context Variable screen is displayed (see Figure 8.25).

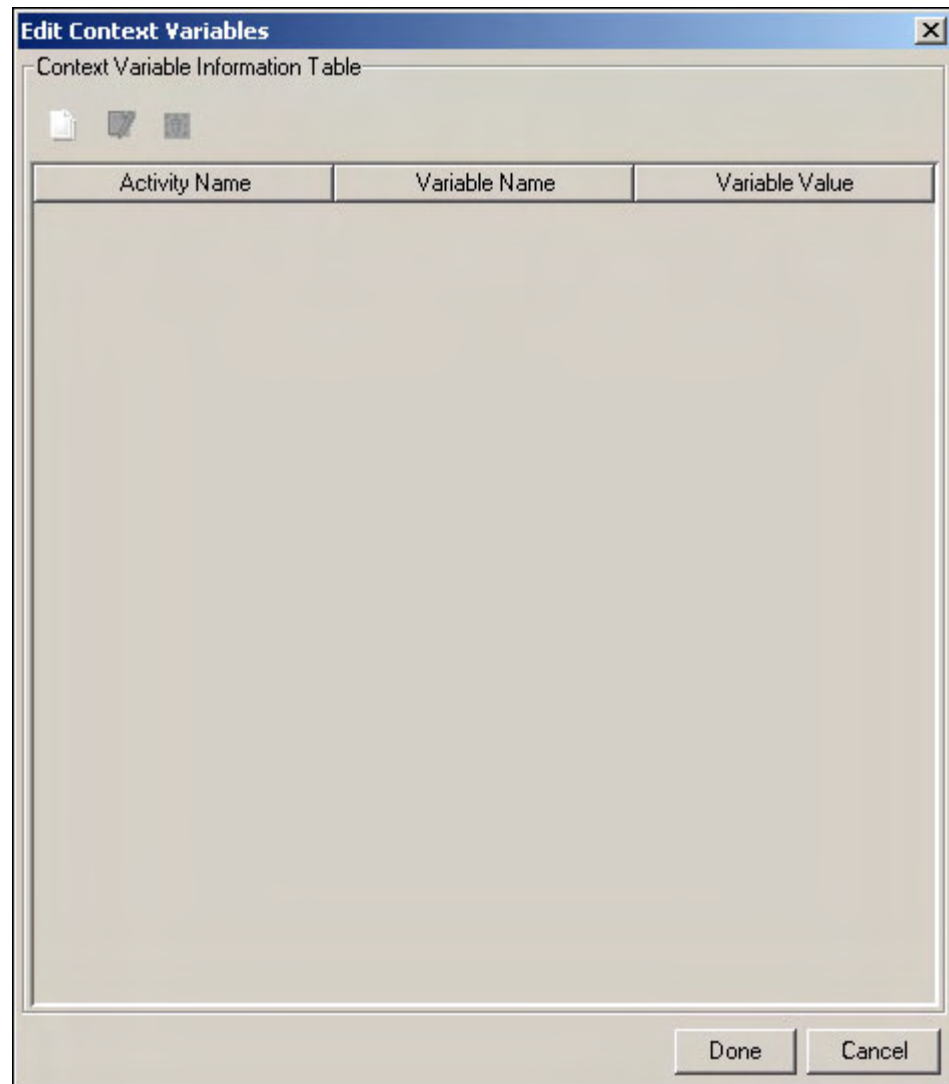



Figure 8.25: Edit Context variable

33. Click **New variable** () button. The Context Variable Information dialog box is displayed (see Figure 8.26).

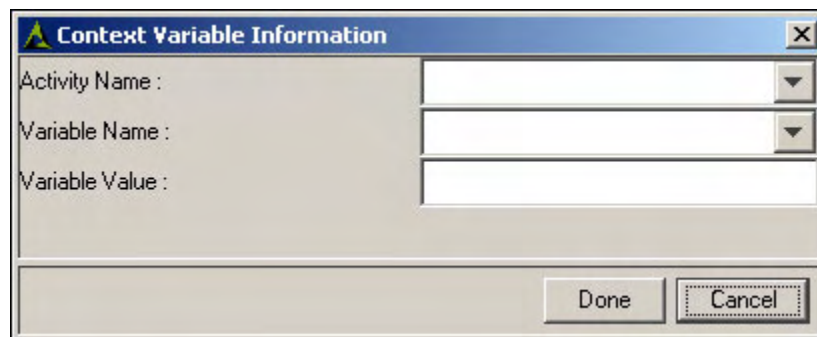

Figure 8.26: Add Context variable

34. Select *nextRecord* from the *Variable Name* drop-down list. *nextRecord* is the name of a Process Flow variable.

35. Enter *yes* in the *Variable Value* field.
36. In this Process Flow, *Put-Context-Var* action is used to change the value of *nextRecord* variable from *no* to *yes*.
37. Once all the activities are dragged to the Graph Canvas Area, they must be connected using appropriate BPMN Flows or Control Flows.
38. Click the **Sequence Flow** (→) icon in the Palette. The Sequence flow is selected.
39. To connect *Start Event* with *EvalRec_FileSource*, drag mouse pointer from *Start Event* to *EvalRec_FileSource* (see Figure 8.27).

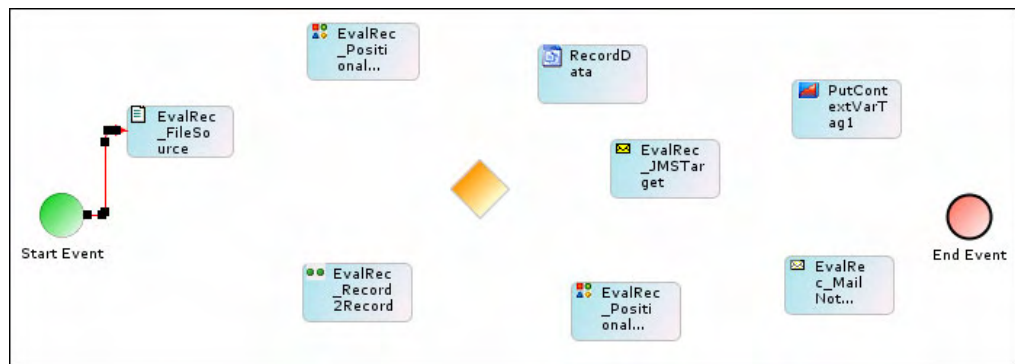

Figure 8.27: Connect Start Event to File Source Activity

40. Similarly, connect all other activities as shown in Figure 8.28.

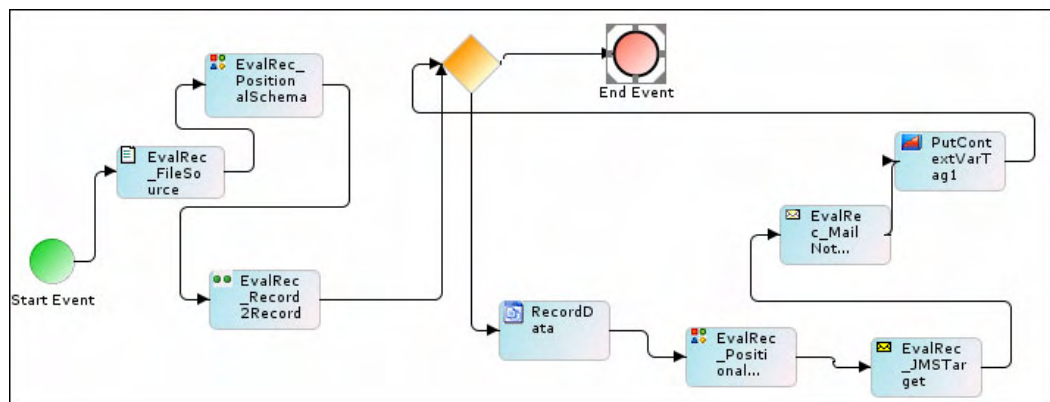

Figure 8.28: Connect all Activities

41. To define the decision criteria, right-click the Control Flow between *Gateway* and the *End Event*, and select **View Properties**. Properties of the selected control flow are shown (see Figure 8.29).

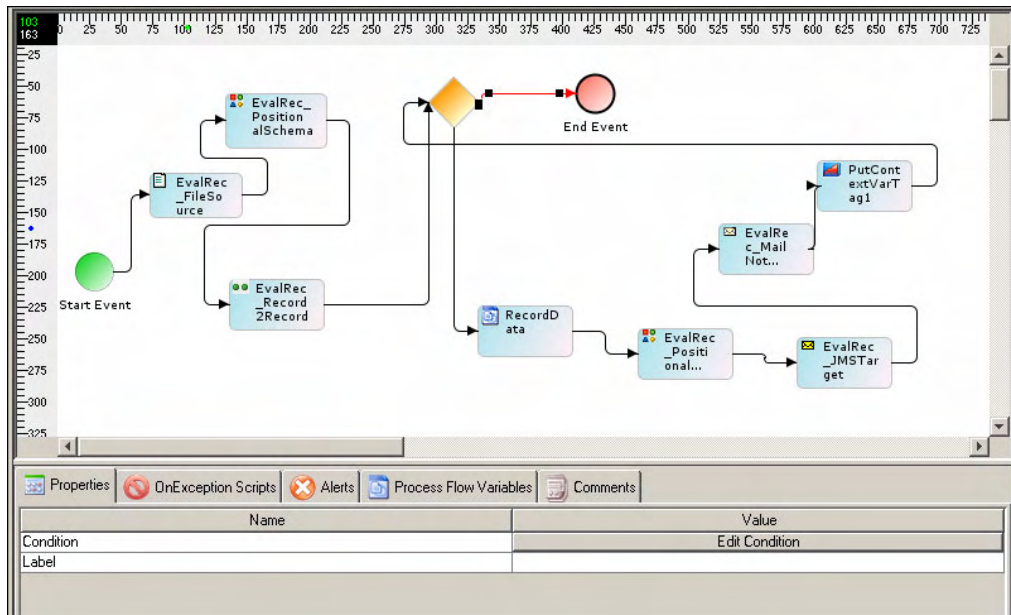

Figure 8.29: View Properties of Control Flow between Gateway Element and End Event

42. Click **Edit Condition**. The Condition Wizard is displayed (see Figure 8.30).

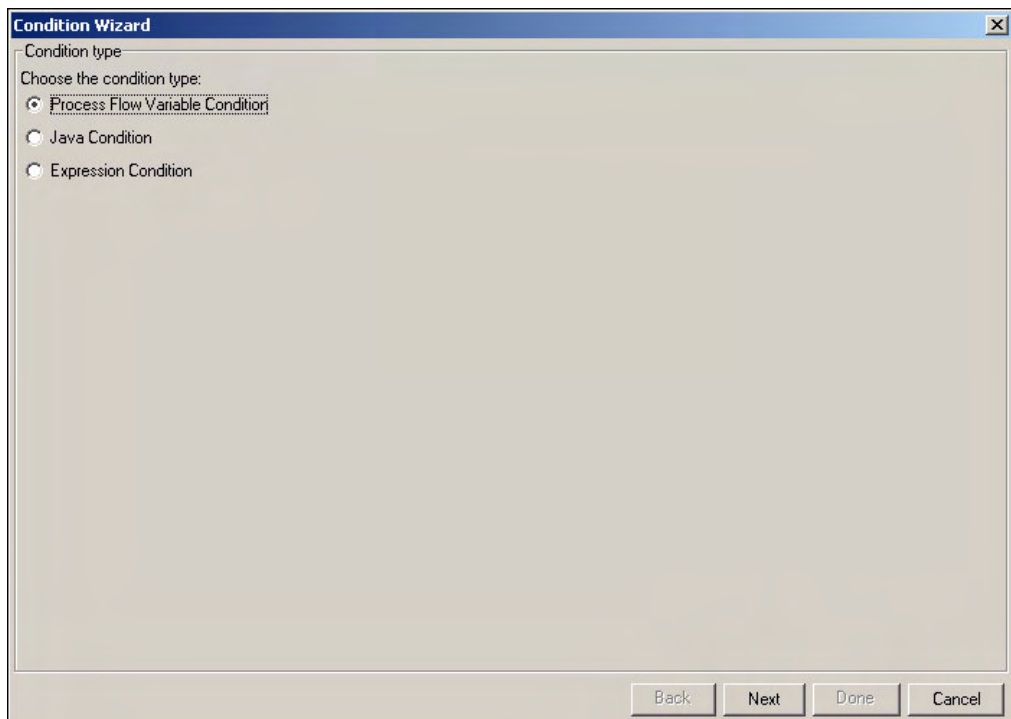

Figure 8.30: Condition Wizard

43. Select **Java Condition** and then click the **Next** button. The Java Condition box is displayed (see Figure 8.31).

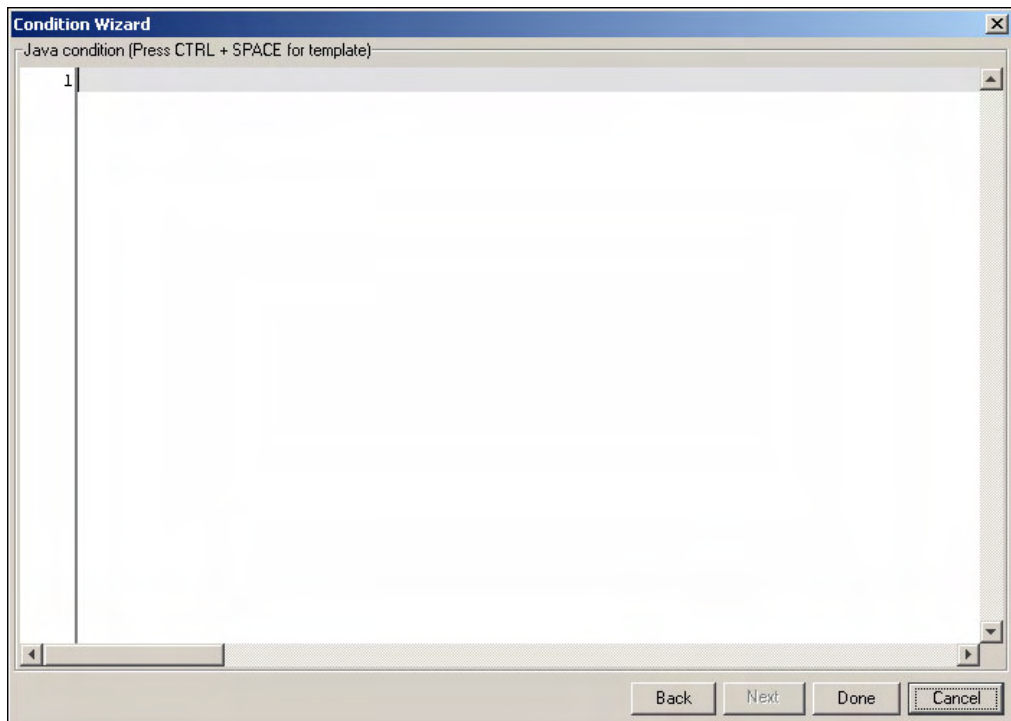

Figure 8.31: Enter JAVA Condition

44. Enter the sample Java Code in the Java Condition box (see Figure 8.32) and click the **Done** button.

```

//Getting Process Flow variable(nextRecord) value
String next= (String)context.get("nextRecord");
if( next.equals("yes") ){
    //wait for 10 seconds before end of Process Flow and recheck Process
    Flow variable(nextRecord) value
    Thread.sleep(10000);
    next= (String)context.get("nextRecord") ;
    if(next.equals("yes")){
        return true ;
    }
}
return false;

```

Figure 8.32: Enter JAVA Code

45. In Graph Canvas Area, right-click the BPMN Gateway element and select **Sequence Flow Ordering** option. The Sequence Flow Ordering dialog box is displayed (see Figure 8.33).

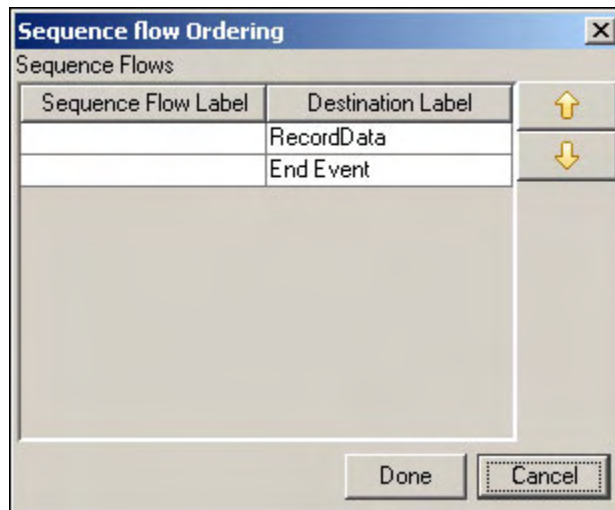



Figure 8.33: Sequence Flow Ordering

46. Select the control, which is connecting **Gateway** and **End Event** and click **UP Arrow** (↑).
47. Click the **Done** button to close the Sequence Flow Ordering Dialog box.

	A default outgoing sequence flow is added for the Gateway. While executing a process flow, if none of the specified conditions are met, then the default gateway is executed. If there is no default gateway specified, then an error occurs at the Process Flow design level.
--	--

48. Right click the **EvalRec_Record2Record** activity and select **Properties** option. Properties of *EvalRec_Record2Record* are shown in the Properties Panel of the bottom pane (see Figure 8.34).

Name		Value
Character Set Encoding		ISO-8859-1
Generate Stream		true
ID		192168001205112194445235900004
Label		EvalRec_Record2Record
Name		EvalRec_Record2Record
source		EvalRec_PositionalSchema
streamNames		
Synch		true
Type		ScriptedRecord2RecordTransformer

Figure 8.34: View Properties of *EvalRec_Record2Record* Activity

49. Change the value of property *Synch* from *true* to *false*.
50. Change the value of property *Generate Stream* from *true* to *false*.
51. Save the Process Flow by clicking the **File** menu and selecting **Save Process Flow to Server**. A dialog box is displayed confirming that the *EvalRec_ProcessFlow* has been saved successfully. If the *comments* property is enabled, then clicking **Save Process Flow to Server** will display a screen where you need to enter comments related to creating the process flow (refer to Figure 7.37).
52. Enter the comments in the *Specify Comments for process flow customer* field.



The comment should be at least 1 character in length.

53. Click **OK** to save the comments. This displays a screen confirming that the process flow has been created successfully.
54. Exit the Process Designer by clicking the **File** menu and selecting **Exit**.

9 APPENDIX A: SETTING UP OPENJMS

This appendix describes how to install and configure OpenJMS server.

INSTALLING OPENJMS

Steps to download and install OpenJMS:

1. Download the OpenJMS version 0.7.6.1 from any of the following URLs:
 - <http://openjms.sourceforge.net/downloads.html>
 - http://sourceforge.net/project/showfiles.php?group_id=54559
2. Unzip the downloaded file on the same machine where you have installed Adeptia Suite.
3. Go to `C:\openjms-0.7.6.1\config` folder and open `openjms.xml` file in a text editor.
4. Copy the following content (see Figure 9.1) in `openjms.xml` file, just below the Server Configuration tag.

```
<RmiConfiguration embeddedRegistry="true"
  registryHost="localhost"
  registryPort="2099">
</RmiConfiguration>

<JndiConfiguration>
  <property name="java.naming.factory.initial"
    value="com.sun.jndi.rmi.registry.RegistryContextFactory"/>
  <property name="java.naming.provider.url"
value="rmi//localhost:2099" />
</JndiConfiguration>
```

Figure 9.1: Content to be copied in `openjms.xml` file

5. After copying the above content the `openjms.xml` file will look like as shown below (see Figure 9.2).

```
<!-- Optional. This represents the default configuration -->
<ServerConfiguration host="localhost" embeddedJNDI="true" />

<RmiConfiguration embeddedRegistry="true"
  registryHost="localhost"
  registryPort="2099">
</RmiConfiguration>

<JndiConfiguration>
  <property name="java.naming.factory.initial"
    value="com.sun.jndi.rmi.registry.RegistryContextFactory"/>
  <property name="java.naming.provider.url"
value="rmi//localhost:2099" />
```

```
</JndiConfiguration>
```

Figure 9.2: Content copied in *openjms.xml* file

6. Save the file and close it.
7. Set following parameter as System environment variable:

JAVA_HOME = "C:\Program Files\adeptiajre\jre"

OPENJMS_HOME = "C:\openjms-0.7.6.1"

STARTING OPENJMS

Steps to start OpenJMS Server:

1. To start the OpenJMS server, on command prompt type the following command:

```
CD %OPENJMS_HOME%\bin
```
2. Now enter the command:

```
Startup
```
3. OpenJMS server is started (see Figure 9.3).

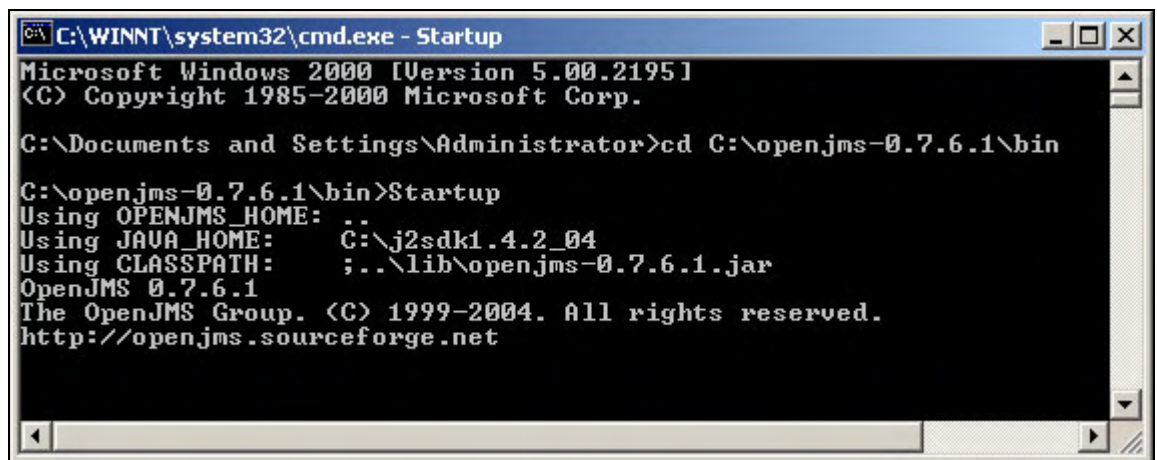

```

C:\WINNT\system32\cmd.exe - Startup
Microsoft Windows 2000 [Version 5.00.2195]
(C) Copyright 1985-2000 Microsoft Corp.

C:\Documents and Settings\Administrator>cd C:\openjms-0.7.6.1\bin

C:\openjms-0.7.6.1\bin>Startup
Using OPENJMS_HOME: ..
Using JAVA_HOME:    C:\j2sdk1.4.2_04
Using CLASSPATH:   ;..\lib\openjms-0.7.6.1.jar
OpenJMS 0.7.6.1
The OpenJMS Group. (C) 1999-2004. All rights reserved.
http://openjms.sourceforge.net
  
```

Figure 9.3: Start OpenJMS Server

To stop the OpenJMS Server, press <Ctrl> + <C>

OPENING OPENJMS

Pre-Requisites:

OpenJMS server must be started before opening the Admin GUI.

Steps to open OpenJMS Admin GUI:

1. To open the OpenJMS admin screen, open another command prompt and type the following command:
`CD %OPENJMS_HOME%\bin`
2. Now enter the command:
`Admin`
3. OpenJMS admin screen is displayed (see Figure 9.4).

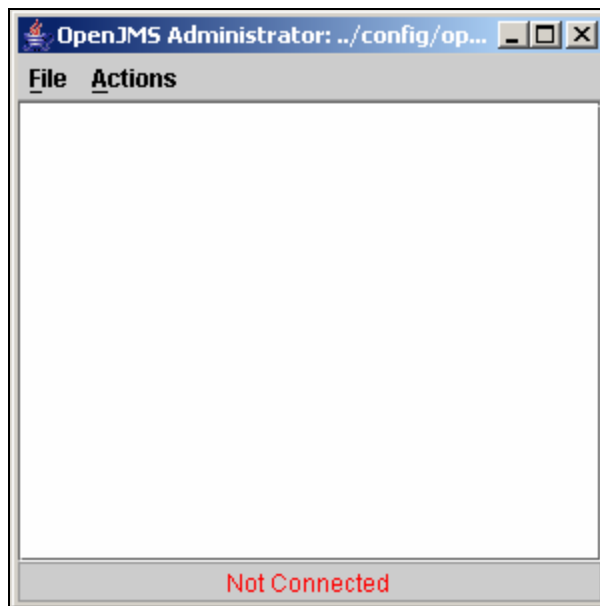

Figure 9.4: Start OpneJMS Admin GUI

4. Click **Actions** menu, go to **Connections** and then select **Online**. Default Queues and topics are displayed (see Figure 9.5).

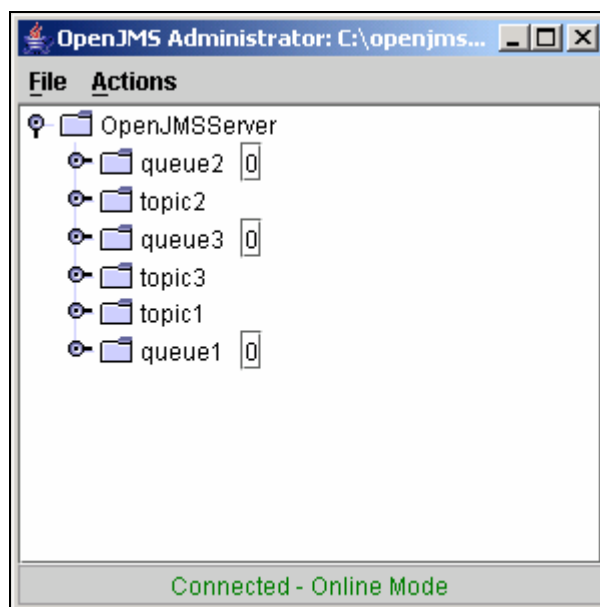

Figure 9.5: Connect to OpenJMS Server

5. To close the Admin screen, click **File** menu and select **Exit**.

10 ABOUT ADEPTIA INC.

Adeptia, an enterprise software company headquartered in Chicago, Illinois, provides business process integration technology to easily and quickly automate business processes using industry-specific standards. Adeptia's unique product combines business process management with business-to-business integration. Adeptia's reusable and highly scalable technology has been deployed by Fortune 1000 companies. For more information, visit www.adeptia.com.

Adeptia Headquarters
443 North Clark St, Suite 350
Chicago, IL 60654
USA
Email: info@adeptia.com

Adeptia India R&D Centre
D-74, Sector 63,
Noida, U.P. - 201301
India

11 TABLE OF FIGURES

Figure 3.1: Data Transformation Process Flow	9
Figure 3.2: View Process Flow Monitor	12
Figure 3.3: Process Flow Logs.....	12
Figure 3.4: Process Flow Log Details.....	13
Figure 3.5: Edit <i>EvalXForm_DBDriver</i>	14
Figure 3.6: Edit <i>EvalXForm_DBInfo</i>	16
Figure 3.7: Edit <i>EvalXForm_DBSchema</i> Activity.....	18
Figure 3.8: Manage Database Source	20
Figure 3.9: Edit <i>EvalXForm_DBSource</i> Activity	20
Figure 3.10: Edit <i>EvalXForm_Mapping</i> Activity	21
Figure 3.11: <i>EvalXForm_Mapping</i> Activity in the Data Mapper Applet.....	22
Figure 3.12: View Mapping Functions used in <i>EvalXForm_Mapping</i> Activity.....	23
Figure 3.13: Select Mapping Function Information	24
Figure 3.14: View Mapping Function Information	24
Figure 3.15: Manage Excel Schema	26
Figure 3.16: Edit <i>EvalXForm_ExcelSchema</i> Activity.....	26
Figure 3.17: Manage File Target	28
Figure 3.18: Edit <i>EvalXForm_FileTarget</i> Activity	29
Figure 3.19: Manage Native Call	30
Figure 3.20: Edit <i>EvalXForm_NativeCall</i> Activity	31
Figure 3.21: Create Data Mapping Activity.....	32
Figure 3.22: Data Mapper Applet	33
Figure 3.23: Select Schema	33
Figure 3.24: Source and Target Elements.....	34
Figure 3.25: Apply <i>For Each</i> Property.....	35
Figure 3.26: Select Target Node	36
Figure 3.27: Select Position Function.....	37
Figure 3.28: Map Position Function to Serial No.....	38
Figure 3.29: Map Policy Numbers	39
Figure 3.30: Select Name Insured.....	40
Figure 3.31: Select Source Nodes	41
Figure 3.32: Create Links.....	42
Figure 3.33: Apply Mapping	43
Figure 3.34: Custom Methods Pane	44
Figure 3.35: Add Custom Method.....	45
Figure 3.36: Save Custom Method	46
Figure 3.37: Select Custom Method.....	47
Figure 3.38: Map Custom Method	48
Figure 3.39: Select Source Nodes	49
Figure 3.40: Map Premium Nodes	50
Figure 3.41: Input Dialog Box.....	50
Figure 3.42: Constant Value Entered	51
Figure 3.43: Create Links.....	52
Figure 3.44: Select IFF Condition	53
Figure 3.45: Map IFF Condition with Target Element	54
Figure 3.46: Drag Database Source to Graph Canvas Area.....	56
Figure 3.47: View Properties of <i>EvalXFormExcelSchema</i> Activity.....	57
Figure 3.48: Connect Start Event to Database Source.....	58
Figure 3.49: Connect all Activities	58
Figure 4.1: Flow Chart to Show Scripted Service Process Flow.....	60
Figure 4.2: Searched Process Flows.....	62

Figure 4.3: View Process Flow Log Details	62
Figure 4.4: Manage File Source.....	63
Figure 4.5: Edit <i>EvalScript_FileSource</i> Activity	64
Figure 4.6: Sample JAVA Code	65
Figure 4.7: Manage Custom Plugins.....	66
Figure 4.8: Edit <i>EvalScript_ScriptedService</i> Activity	66
Figure 4.9: Edit <i>EvalScript_TextSchema</i> Activity.....	68
Figure 4.10: Edit <i>EvalScript_Mapping</i> Activity	70
Figure 4.11: <i>EvalScript_Mapping</i> Activity in Data Mapper.....	71
Figure 4.12: Edit <i>EvalScript_ExcelSchema</i> Activity.....	73
Figure 4.13: Edit <i>EvalScript_FileTarget</i> Activity	75
Figure 4.14: Drag File Source to Graph Canvas Area.....	77
Figure 4.15: View Properties of <i>EvalScript_ExcelSchema</i> Activity	78
Figure 4.16: Drag Put-Context Var to Graph Canvas Area.....	78
Figure 4.17: Connect Start Event to File Source	79
Figure 4.18: Connect all Activities	79
Figure 4.19: View Put-Context Var Properties	79
Figure 4.20: Edit Context Variable.....	80
Figure 4.21: Add Context Variable.....	80
Figure 4.22: Multiple Stream Dialog Box	82
Figure 4.23: Define Data Stream	83
Figure 4.24: Data Stream Created	83
Figure 5.1: Flow Chart to show Process Flow	86
Figure 5.2: View Searched Process Flows	88
Figure 5.3: View Process Flow Log Details	89
Figure 5.4: Edit <i>EvalPD_FileSource</i> Activity.....	90
Figure 5.5: Edit <i>EvalPD_FileTarget</i> Activity	91
Figure 5.6: Manage Mail Target	93
Figure 5.7: Edit <i>EvalPD_MailTargetLessThan50K</i> Activity	94
Figure 5.8: Drag File Source Activity to Graph Canvas Area	97
Figure 5.9: Process Flow Variables Panel	97
Figure 5.10: Create Process Flow Variable	98
Figure 5.11: Drag Context Source Activity to Graph Canvas Area.....	98
Figure 5.12: View Properties of Context Target Activity	98
Figure 5.13: Enter Context Target Name.....	99
Figure 5.14: View Properties of Context Source activity.....	99
Figure 5.15: Enter Context Source Name	99
Figure 5.16: Drag BPMN Gateway Element to Graph Canvas Area.....	100
Figure 5.17: Drag Trace Action	100
Figure 5.18: View Properties of Trace Action.....	101
Figure 5.19: Drag another Trace Action	102
Figure 5.20: Connect Start Event to File Source Activity	102
Figure 5.21: Connect all Activities	103
Figure 5.22: Create Stream.....	104
Figure 5.23: Add another Stream.....	105
Figure 5.24: Multiple Streams Created.....	105
Figure 5.25: Sample JAVA Code.....	106
Figure 5.26: Define Decision Criteria	106
Figure 6.1: Flow Chart of the Process Flow	109
Figure 6.2: Manage Mail Event.....	113
Figure 6.3: Searched Process Flows.....	114
Figure 6.4: View Process Flow Log Details	114
Figure 6.5: Edit <i>EvalPF_MailEvent_Format1</i> Activity.....	116
Figure 6.6: Manage Mail Source.....	118
Figure 6.7: Edit <i>EvalPF_MailSource</i> Activity	119
Figure 6.8: Edit <i>EvalPF_ExcelSchema_Format1</i> Activity	122
Figure 6.9: Edit <i>EvalPF_MappingTransformation_Format1</i> Activity.....	124

Figure 6.10: Edit <i>EvalPF_MappingTransformation_Format1</i> Activity in Data Mapper Applet	125
Figure 6.11: View Mapping Functions Used in <i>EvalPF_MappingTransformation_Format1</i> Activity.....	126
Figure 6.12: Select Mapping Function Information	127
Figure 6.13: View Mapping Function Information	127
Figure 6.14: Edit <i>EvalPF_DatabaseDriver_SQLServer</i>	129
Figure 6.15: Edit <i>EvalPF_Databaseinfo_SQLServer</i>	131
Figure 6.16: Edit <i>EvalPF_DatabaseSchema_Database1</i> Activity.....	133
Figure 6.17: Edit <i>EvalPF_DatabaseTarget_Database1</i> Activity.....	135
Figure 6.18: Edit <i>EvalPF_FileTarget_ErrorRecord</i> Activity	137
Figure 6.19: Expand Source and Target Schemas.....	140
Figure 6.20: Apply For Each Property.....	141
Figure 6.21: Map Account Numbers.....	142
Figure 6.22: Map Source and Target Elements of First Target Schema	143
Figure 6.23: Mapping Source and Target Elements of All Target Schemas	144
Figure 6.24: Custom Methods Pane	145
Figure 6.25: Create Custom Method	146
Figure 6.26: Save Custom Method	147
Figure 6.27: Select Custom Method.....	148
Figure 6.28: Constant Value Entered	149
Figure 6.29: Create Links.....	150
Figure 6.30: Select IF Condition.....	151
Figure 6.31: Apply Mapping	152
Figure 6.32: Assign Streams	153
Figure 6.33: Enter Stream Name	153
Figure 6.34: Drag File Source Activity to Graph Canvas Area.....	155
Figure 6.35: Drag BPMN Gateway Element to Graph Canvas Area	156
Figure 6.36: Connect Start Event to File Source Activity	156
Figure 6.37: Connect all Activities	157
Figure 6.38: Define Decision Criteria	157
Figure 6.39: Process Flow Variable Condition Type	158
Figure 6.40: Select Activity Attributes.....	158
Figure 6.41: Select Attribute Value for <i>Format1</i>	159
Figure 6.42: Select Activity Attributes for <i>Format2</i>	160
Figure 6.43: Drag <i>Put-Context-Var</i> to Graph Canvas Area.....	160
Figure 6.44: Connect Activities	161
Figure 6.45: View Properties of <i>Seq_File_Path</i>	161
Figure 6.46: Edit Context Variable.....	162
Figure 6.47: Add Context Variable.....	162
Figure 6.48: Connect Activities	163
Figure 6.49: Drag <i>Put-Context-Var</i> to Graph Canvas Area.....	164
Figure 6.50: Connect Activities	164
Figure 6.51: Connect Activities	165
Figure 6.52: Multiple Streams Created.....	166
Figure 6.53: Multiple Streams Created for Multiple Activities	167
Figure 6.54: Edit <i>EvalPF_MailEventRegistry_Format1</i> Activity.....	168
Figure 7.1: Flow Chart showing JMS Driven Process Flow.....	171
Figure 7.2: Manage JMS Event.....	175
Figure 7.3: Send File to OpenJMS Server	176
Figure 7.4: Process Flow Log.....	176
Figure 7.5: Searched Process Flows.....	177
Figure 7.6: Process Flow Log Details.....	177
Figure 7.7: Process Flows Summary	178
Figure 7.8: Manage JMS Provider	178
Figure 7.9: Edit JMS Provider Activity	179
Figure 7.10: Enter Comments.....	180

Figure 7.11: Edit JMS Event Activity	181
Figure 7.12: Manage Text Schema	183
Figure 7.13: Edit Text Schema Activity	183
Figure 7.14: Test Schema	185
Figure 7.15: Manage Data Mapping	186
Figure 7.16: Edit <i>EvalJMSE_Mapping</i> Activity	187
Figure 7.17: Mapping between Source and Target Schemas	187
Figure 7.18: Enter Comments (Mapping)	188
Figure 7.19: Manage Database Driver	189
Figure 7.20: Edit <i>SQLServerJTDSDriver</i>	189
Figure 7.21: Manage Database Info	191
Figure 7.22: Edit <i>EvalJMSE_DBInfo</i>	191
Figure 7.23: Manage Database Schema	193
Figure 7.24: Edit <i>EvalJMSE_DBSchema</i> Activity	194
Figure 7.25: Manage Database Target	196
Figure 7.26: Edit <i>EvalJMSE_DBTarget</i> Activity	196
Figure 7.27: Manage Process Flow	198
Figure 7.28: Create Process Flow	199
Figure 7.29: Process Designer Applet	200
Figure 7.30: Drag Context Source to Graph Canvas	201
Figure 7.31: View Properties of Context Source Activity	202
Figure 7.32: Context Source Name	202
Figure 7.33: Drag Text Schema to Graph Canvas Area	203
Figure 7.34: Drag Database Target to Graph Canvas Area	203
Figure 7.35: Connect Start Event to Context Source	203
Figure 7.36: Connect all Activities	204
Figure 7.37: Enter Comments (Process Flow)	204
Figure 7.38: Manage Event Registry	205
Figure 7.39: Edit <i>EvalJMSE_Event Registry</i>	205
Figure 8.1: Flow Chart to show Process Flow	207
Figure 8.2: View Process Flow Logs	210
Figure 8.3: View Process Flow Log Details	210
Figure 8.4: Edit <i>EvalRec_File Source</i> Activity	211
Figure 8.5: Manage Positional Schema	213
Figure 8.6: Edit <i>EvalRec_PositionalSchema</i> Activity	213
Figure 8.7: Sample JAVA Code	216
Figure 8.8: Manage Record to Record	216
Figure 8.9: Edit <i>EvalRec_Record2Record</i> Activity	217
Figure 8.10: Edit <i>EvalRec_JMS Provider</i> Activity	218
Figure 8.11: Manage JMS Target	220
Figure 8.12: Edit <i>EvalRec_JMSTarget</i> Activity	220
Figure 8.13: Manage Mail Notification	222
Figure 8.14: Edit <i>EvalRec_MailNotification</i> Activity	222
Figure 8.15: Select File Source Activity	225
Figure 8.16: Drag BPMN Gateway to Graph Canvas Area	226
Figure 8.17: Process Flow Variables Panel	226
Figure 8.18: Create Process Flow Variable	226
Figure 8.19: Drag Context Source to Graph Canvas Area	227
Figure 8.20: Drag Context Source to Graph Canvas Area	227
Figure 8.21: Enter Context Source Name	228
Figure 8.22: Change Activity Name	228
Figure 8.23: Select Put-Context -Var	229
Figure 8.24: View Properties of Put-Context-Var	229
Figure 8.25: Edit Context variable	230
Figure 8.26: Add Context variable	230
Figure 8.27: Connect Start Event to File Source Activity	231
Figure 8.28: Connect all Activities	231

Figure 8.29: View Properties of Control Flow between Gateway Element and End Event	232
Figure 8.30: Condition Wizard	232
Figure 8.31: Enter JAVA Condition.....	233
Figure 8.32: Enter JAVA Code.....	233
Figure 8.33: Sequence Flow Ordering	234
Figure 8.34: View Properties of <i>EvalRec_Record2Record</i> Activity.....	234
Figure 9.1: Content to be copied in <i>openjms.xml</i> file.....	237
Figure 9.2: Content copied in <i>openjms.xml</i> file.....	238
Figure 9.3: Start OpenJMS Server	238
Figure 9.4: Start OpneJMS Admin GUI	239
Figure 9.5: Connect to OpenJMS Server	240

12 TABLE OF TABLES

Table 3.1: Structure of Database Table used as Source	11
Table 3.2: Structure of Excel Table used as Target	11
Table 3.3: Details of Fields on Edit Database Driver Screen.....	14
Table 3.4: Details of Fields on Edit Database Info Screen.....	16
Table 3.5: Details of Fields on Edit Database Schema Screen	18
Table 3.6: Details of Fields on Edit Database Source Screen.....	20
Table 3.7: Details of Fields on Edit Excel Schema Screen.....	27
Table 3.8: Details of Fields on Edit File Target Screen	29
Table 3.9: Details of Fields on Edit Native Call Screen	31
Table 4.1: Structure of Text File used as Source.....	61
Table 4.2: Details of Fields on Edit File Source Screen.....	64
Table 4.3: Details of Fields on Edit Custom Plugin Screen	66
Table 4.4: Details of Fields on Edit Text Schema Screen	68
Table 4.5: Details of Fields on Edit Excel Schema Screen.....	73
Table 6.6 Details of Fields on Edit File Target Screen.....	75
Table 5.1: Structure of Text File used as Source.....	87
Table 5.2: Details of Fields on Edit File Source Screen.....	90
Table 5.3: Details of Fields on Edit File Target Screen	92
Table 5.4: Details of Fields on Edit Mail Target Screen.....	94
Table 6.1: Format 1 of Excel Files used as Source	111
Table 6.2: Format 2 of Excel Files used as Source	111
Table 6.3: Fields of Databases used as Target.....	112
Table 6.4: Details of Fields on Edit Mail Event Screen.....	117
Table 6.5: Details of Fields on Edit Mail Source Screen	120
Table 6.6: Details of Fields on Edit Excel Schema Screen	122
Table 6.7: Details of Fields on Edit Database Driver Screen.....	129
Table 6.8: Details of Fields on Edit Database Info Screen.....	131
Table 6.9: Details of Fields on Edit Database Schema Screen	134
Table 6.10: Details of Fields on Edit Database Target Screen	135
Table 6.11: Details of Fields on Edit File Target Screen.....	138
Table 6.12: Target Activities and Java Method Values	139
Table 6.13: Changed Properties	163
Table 6.14: Changed Properties	164
Table 6.15: Details of Fields on Edit Event Registry Screen	168
Table 7.1: Structure of Stock Quote Data	172
Table 7.2: Details of Fields on Edit JMS Provider Screen	179
Table 7.3: Details of Fields on Edit JMS Events Screen	181
Table 7.4: Details of Fields on Edit Text Schema Screen.....	184
Table 7.5: Details of Fields on Edit Database Driver Screen.....	189
Table 7.6: Details of Fields on Edit Database Info Screen.....	191
Table 7.7: Details of Fields on Edit Database Schema Screen	194
Table 7.8: Details of Fields on Edit Database Target Screen	196
Table 7.9: Logging Levels	199
Table 7.10: Repository File Retention Options.....	200
Table 7.11: Details of Fields on Edit Event Registry Screen	205
Table 8.1: Structure of Positional File used as Source	209
Table 8.2: Details of Fields on Edit File Source Screen.....	212
Table 8.3: Details of Fields on Edit Positional Schema Screen.....	213
Table 8.4: Details of Fields on Edit Record to Record Screen	217
Table 8.5: Details of Fields on Edit JMS Provider Screen	218
Table 8.6: Details of Fields on Edit JMS Target Screen.....	220
Table 8.7: Details of Fields on Edit Mail Notification Screen	223

